

G

DRILL

Korloy drills provide a total solution for hole making, based on tooling know-how as well as extensive research and development for our tools.



Technical Information for Drills

- G02 KORLOY Drills
- G04 Available Insert

Indexable Drills









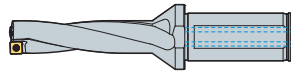
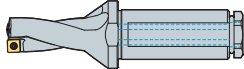
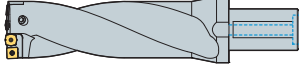
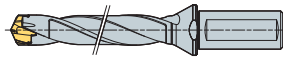
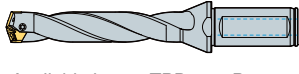
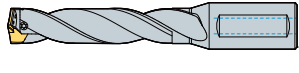

- G06 Technical Information for King Drill
- G12 King Drill
- G21 Technical information of King Drill
(for through coolant system with a lathe)
- G22 King Drill (for through coolant system with a lathe)
- G25 Technical Information for King Drill
(for large diameter drilling)
- G26 King Drill (for large diameter drilling)
- G27 Technical Information for TPDC
- G31 TPDC
- G34 Technical Information for TPDB Plus
- G38 TPDB Plus
- G44 Technical Information for TPDB-H
- G47 TPDB-H
- G51 Technical Information for WPDC
- G54 Center Drill
- G55 WPDC

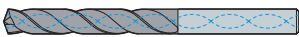
Solid Drills





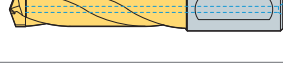





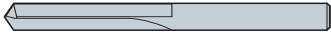

- G57 Technical Information for Mach Solid Drill Plus
- G59 Mach Solid Drill Plus
- G64 Technical Information for Mach Solid Drill Plus-S
- G66 Mach Solid Drill Plus-S
- G70 Technical Information for Mach Solid Drill plus CFRP
- G72 Mach Solid Drill Plus CFRP
- G73 Technical Information for Mach Solid Flat Drill
- G76 Mach Solid Flat Drill
- G82 Technical Information for Mach long Drill Plus
- G84 Mach long Drill Plus
- G87 Mach step Drills Order Form
- G88 Technical Information for Vulcan Drill
- G89 Vulcan Drill
- G91 Technical Information for ESD Plus
- G93 ESD Plus
- G98 Technical Information for Carbide Drill (SSDP)
- G99 Carbide Drill (SSDP)
- G101 Burnishing Drill
- G102 Top Solid Drill
- G103 PCD Drill
- G104 Technical Information for Gun Drill
- G108 Gun Drill

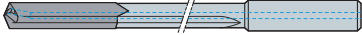
Reamer

- G110 Technical Information for Indexable Reamer
- G113 Indexable Reamer
- G116 Chucking/Machine Reamer
- G119 PCD Reamer
- G120 Cermet Reamer
- G121 Broach Reamer

Type	Designation		Shape	Drills dia.	Aspect ratio	Page
Indexable Drills	King Drill	K□D	 Available insert: SP□T, XO□T	Ø12.0~Ø60.5	2D~5D	G12 ~ G20
	King Drill HP	K□D..HP	 Available insert: SP□T, XO□T	Ø12.0~Ø60.5	2D~4D	G22 ~ G24
	King Drill (for large diameter drilling)	K□D	 Available insert: SP□T, XO□T	Ø61.0~Ø100.0	2D~4D	G26
	TPDC ^{new}	TPDC	 Available insert: TP□□□□CP	Ø12.0~Ø30.9	3D~12D	G32 ~ G33
	TPDB Plus ^{new}	TPDB-P	 Available insert: TP□□□□B	Ø10.0~Ø32.9	3D~12D	G39 ~ G43
	TPDB-H ^{new}	TPDB-H	 Available insert: TP□□□□B-H	Ø14.0~Ø30.4	3D~8D	G48 ~ G50
	Indexable Drills & Drill with center	WPDC	 Available insert: WC□T	Ø25.0~Ø80.0	5D~8D	G55 ~ G56
Solid Drills	Mach Solid Drill Plus ^{new}	MSDP		Ø1.0~Ø20.0	3D~7D	G59 ~ G63
		MSDPH		Ø2.5~Ø20.0	3D~7D	G60 ~ G63
	Mach Solid Drill Plus-S ^{new}	MSDPH-S		Ø3.0~Ø16.0	3D~5D	G66 ~ G69
	Mach Solid Drill Plus CFRP ^{new}	MSDP-C		Ø3.0~Ø12.7	5D	G72
	Mach Solid Flat Drill ^{new}	MSFD		Ø2.5~Ø16.0	2D	G76 ~ G78
		MSFDH		Ø2.5~Ø16.0	3D	G79 ~ G81
	Mach Long Drill Plus ^{new}	MLD□□□□N		Ø3.0~Ø10.0	10D~25D	G84 ~ G86
	Vulcan Drill	VZD		Ø12.6~Ø40.5	-	G89 ~ G90
	ESD Plus ^{new}	ESDP		Ø1.0~Ø20.0	3D~7D	G93 ~ G97

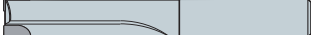

Type	Designation		Shape	Drills dia.	Aspect ratio	Page
Solid Drills	Carbide Drill ^{new}	SSDP		Ø1.0~Ø15.0	-	G99 ~ G100
	Burnishing Drill	BDS		Ø4.0~Ø16.0	5D~7D	G101
		BDT		Ø4.2~Ø10.3	2D~4D	G101
	Top solid Drill	TSDM		Ø8.0~Ø25.0	5D~8D	G102
	PCD Drill	PDD		Ø5.0~Ø12.0	5D	G103
	Gun Drill	KGDS		Ø2.0~Ø33.0	50D~100D	G108
		KGDT		Ø6.0~Ø26.5	50D~100D	G109
	Reamer	Indexable Reamer	IRT	 Available Insert: RI	Ø10.0~Ø31.0	3D~5D
IRB			 Available Insert: RI	Ø10.0~Ø31.0	3D~5D	G115
Chucking/Machine Reamer		SCRS		Ø5.0~Ø20.0	2D~3D	G117
		SCRH		Ø5.0~Ø20.0	2D~3D	G117
		TCRS		Ø7.0~Ø30.0	2D~3D	G118
		TMRS		Ø7.0~Ø30.0	3D~5D	G118
PCD Reamer		PDR		Ø5.0~Ø20.0	3D~5D	G119
Cermet Reamer		KCR		Ø6.0~Ø30.0	3D~7D	G120
Broach Reamer		HBRE		Ø3.0~Ø25.0	3D~7D	G121







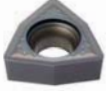
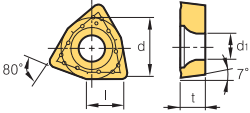

Available insert

Picture	Designation	Coated								Uncoated	Dimensions (mm)					Configuration	Page
		NC5330	NCM535	PC3700	PC5335	PC9530	PC6510	PC5300	PC5400		H01	l	d	t	r		
	040204-ND									●	4.7	-	2.4	0.4	2.3		G12 ~ G26
	050204-ND									●	5.1	-	2.4	0.4	2.3		
	060205-ND									●	6.2	-	2.5	0.5	2.5		
	07T208-ND									●	7.5	-	2.8	0.7	2.8		
	090308-ND									●	9.2	-	3.3	0.8	3.4		
	11T308-ND									●	11.0	-	4.0	0.8	4.0		
	130410-ND									●	13.0	-	4.5	1.0	4.5		
	15M510-ND									●	15.2	-	5.0	1.0	5.5		
	180510-ND									●	18.2	-	5.5	1.0	6.0		
	060205-LD				●						6.2	-	2.5	0.5	2.5		G12 ~ G26
	07T208-LD				●						7.5	-	2.8	0.7	2.8		
	090308-LD				●						9.2	-	3.3	0.8	3.4		
	11T308-LD				●						11.0	-	4.0	0.8	4.0		
	130410-LD				●						13.0	-	4.5	1.0	4.5		
	15M510-LD				●						15.2	-	5.0	1.0	5.5		
	180510-LD				●						18.2	-	5.5	1.0	6.0		
	040204-PD	●	●					●	●		4.7	-	2.4	0.4	2.3		G12 ~ G26
	050204-PD	●	●					●	●		5.1	-	2.4	0.4	2.3		
	060205-PD	●	●					●	●		6.2	-	2.5	0.5	2.5		
	07T208-PD	●	●					●	●		7.5	-	2.8	0.7	2.8		
	090308-PD	●	●					●	●		9.2	-	3.3	0.8	3.4		
	11T308-PD	●	●					●	●		11.0	-	4.0	0.8	4.0		
	130410-PD	●	●					●	●		13.0	-	4.5	1.0	4.5		
	15M510-PD	●	●					●	●		15.2	-	5.0	1.0	5.5		
	180510-PD	●	●					●	●		18.2	-	5.5	1.0	6.0		
	030208-C20N				●						3.8	5.56	2.38	0.8	2.8		-
	040208-C20N				●						4.3	6.35	2.38	0.8	3.0		
	050308-C20N				●						5.4	7.94	3.18	0.8	3.4		
	06T308-C20N				●						6.5	9.525	3.97	0.8	3.7		
	080408-C20N				●						8.7	12.7	4.76	0.8	4.3		
	080412-C20N				●						8.7	12.7	4.76	1.2	4.3		

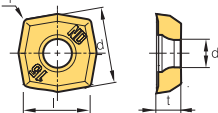
●: Stock Item

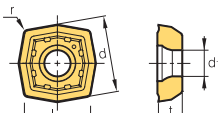

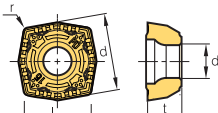
Available insert

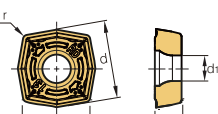
Picture	Designation	Coated								Uncoated HD1	Dimensions (mm)					Configuration	Page
		NC5330	NCM535	PC3700	PC5335	PC9530	PC6510	PC5300	PC5400		l	d	t	r	d ₁		
	030204-C21N				●						3.8	5.56	2.38	0.4	2.55		G55 G56
	040204-C21N				●						4.3	6.35	2.38	0.4	2.8		
	040208-C21N				●						4.3	6.35	2.38	0.8	2.8		
	050308-C21N				●						5.4	7.94	3.18	0.8	3.4		
	06T308-C21N				●						6.5	9.525	3.97	0.8	4.4		
	080408-C21N				●						8.7	12.7	4.76	0.8	5.5		
	040204-ND								●		4.3	4.9	2.4	0.4	2.3		G12 ~ G26
	050204-ND								●		4.8	5.4	2.4	0.4	2.3		
	060204-ND								●		5.8	6.6	2.5	0.4	2.5		
	07T205-ND								●		6.9	7.8	2.8	0.5	2.8		
	090305-ND								●		8.4	9.6	3.3	0.5	3.4		
	11T306-ND								●		10.0	11.4	4.0	0.6	4.0		
	130406-ND								●		11.9	13.6	4.5	0.6	4.5		
	15M508-ND								●		13.9	15.9	5.0	0.8	5.5		
180508-ND								●		16.5	18.9	5.5	0.8	6.0			
	060204-LD				●						5.8	6.6	2.5	0.4	2.5		G12 ~ G26
	07T205-LD				●						6.9	7.8	2.8	0.5	2.8		
	090305-LD				●						8.4	9.6	3.3	0.5	3.4		
	11T306-LD				●						10.0	11.4	4.0	0.6	4.0		
	130406-LD				●						11.9	13.6	4.5	0.6	4.5		
	15M508-LD				●						13.9	15.9	5.0	0.8	5.5		
	180508-LD				●						16.5	18.9	5.5	0.8	6.0		
	040204-PD								●		4.3	4.9	2.4	0.4	2.3		G12 ~ G26
	050204-PD								●		4.8	5.4	2.4	0.4	2.3		
	060204-PD								●		5.8	6.6	2.5	0.4	2.5		
	07T205-PD								●		6.9	7.8	2.8	0.5	2.8		
	090305-PD								●		8.4	9.6	3.3	0.5	3.4		
	11T306-PD								●		10.0	11.4	4.0	0.6	4.0		
	130406-PD								●		11.9	13.6	4.5	0.6	4.5		
	15M508-PD								●		13.9	15.9	5.0	0.8	5.5		
	180508-PD								●		16.5	18.9	5.5	0.8	6.0		
	07T207-RD								●		6.9	7.8	2.8	0.7	2.8		G12 ~ G26
	090308-RD								●		8.4	9.6	3.3	0.8	3.4		
	11T309-RD								●		10.0	11.4	4.0	0.9	4.0		
	130410-RD								●		11.9	13.6	4.5	1.0	4.5		
	15M511-RD								●		13.9	15.9	5.0	1.1	5.5		
	180512-RD								●		16.5	18.9	5.5	1.2	6.0		

● : Stock Item

G Technical Information for King Drill

Optimized insert design for maximum drilling efficiency

King Drill

Code system of holder

K	5D	200	25	□	-	07
KING/KORLOY	Aspect ratio (L/D)	Drill Dia.	Shank Dia	Shank shape		Inscribed circle of insert
	2D, 3D, 4D, 5D	Ø20.0 (One decimal place marked)	Ø20, Ø25 Ø32, Ø40	No mark: Flange Shank, Weldone HP: Flange Shank, Weldon, PT Tap F1: Flange Shank, Whistle Notch F2: Flange Shank, Without Side Lock S: Straight Shank, Weldone S1: Straight Shank, Whistle Notch S2: Straight Shank, Without Side Lock M0, M1, M2, M3...: MT0, MT1, MT2, MT3... H63, H100: HSK63, HSK100 B30, B40, B50: BT30, BT40, BT50		04, 05, 06, 07, 09 11 13, 15, 18

Features

- Optimized design of inserts for maximum drilling efficiency
- Excellent cutting performance and chip control due to the optimized geometry and chip breaker of both inserts, central & peripheral
- Different inserts, optimized for the central and peripheral insert locations in order to maximize cutting tool life

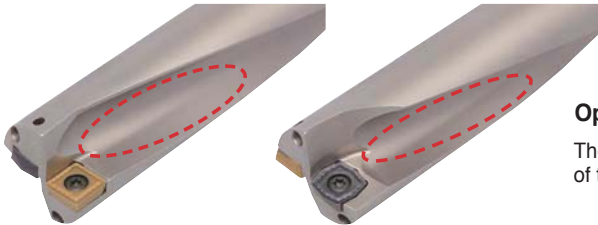

Optimized flute system - 2 coolant holes applied

The optimized shape of the flute increases the rigidity of the drill body and improves chip evacuation

Features of chip breaker

Chip breaker	PD		LD		ND		RD
Features	- Universal - At medium speed and medium feed		- Superior chip control for machining mild steel and stainless steel - Light cutting (at low ~ medium speed and low feed)		- Sharp cutting edge for aluminum machining - Insert surface buffed for high quality result - E Class Tolerance		- Improved chipping resistance - Excellent performance in case of frequent fracture and chipping on the cutting edge
Insert	Peripheral insert	Central insert	Peripheral insert	Central insert	Peripheral insert	Central insert	Central insert
Shape							
Grades for workpiece	NC5330: P, M, K PC3500: P PC5300: P, M, K, S PC6510: K		PC5300: P, M, K, S		PC5335: P, M		H01: N PC5300: P, M, K, S



Application examples

- **Use** Track link bush
- **Workpiece** SM45C
- **Cutting conditions** vc (m/min) = 120, fn (mm/rev) = 0.1
Through coolant system
- **Tools** **inserts** SPMT07T208-PD (PC3500)
XOMT07T205-PD (PC5300)
Holder K5D20025-07
- **Machine** Drilling machine

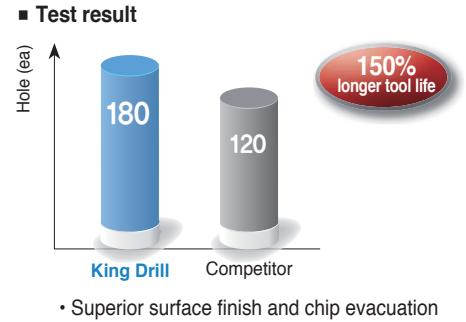

- **Use** Track link bush
- **Workpiece** SCM415H
- **Cutting conditions** King Drill: vc (m/min) = 140, fn (mm/rev) = 0.12
Competitor: vc (m/min) = 125, fn (mm/rev) = 0.1
- **Tools** **inserts** SPMT090308-PD (PC3500)
XOMT090305-PD (PC5300)
Holder K3D27032-09
- **Machine** MCT

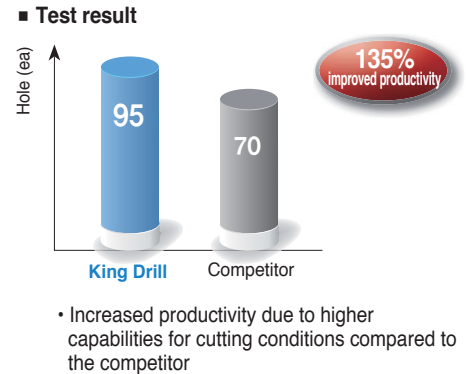

Recommended cutting condition

Workpiece			Insert			vc (m/min)	Aspect ratio (L/D) = 2D, 3D, 4D					
ISO	Workpiece	Hardness (HB)	Chip breaker	Grade			Feed rate (mm/rev) per drill dia. (mm)					
				Central	Peripheral		Ø12~Ø16	Ø17~Ø23	Ø24~Ø29	Ø30~Ø42	Ø43~Ø60	
P	Carbon steel	80~180	LD	PC5335	PC5335	120 (60~170)						
			PD/RD	PC5300	PC3500	150 (120~180)	0.04~0.08	0.04~0.08	0.04~0.08	0.04~0.08	0.04~0.08	
					NC5330	180 (140~220)						
	High carbon steel	180~280	PD	PC5300	PC3500	120 (90~150)	0.04~0.10	0.04~0.12	0.05~0.16	0.06~0.16	0.06~0.18	
					NC5330	150 (110~190)	0.04~0.06	0.04~0.07	0.04~0.08	0.04~0.08	0.04~0.08	
Alloy steel	Low alloy steel	140~260	LD	PC5335	PC5335	120 (60~160)	0.06~0.10	0.06~0.10	0.06~0.12	0.06~0.14	0.06~0.14	
			PD	PC5300	PC3500	150 (120~170)	0.06~0.12	0.06~0.12	0.06~0.14	0.06~0.16	0.06~0.16	
	Hardened low alloy steel	200~400	PD	PC5300	PC5300	100 (50~150)	0.04~0.10	0.06~0.10	0.06~0.12	0.06~0.14	0.06~0.14	
					PC3500	100 (50~160)	0.05~0.11	0.05~0.11	0.05~0.13	0.05~0.15	0.05~0.15	
					PC5300	70 (30~120)	0.04~0.08	0.06~0.08	0.06~0.10	0.06~0.12	0.06~0.12	
Hardened high alloy steel	300~450	PD	PC5300	PC5300	70 (30~120)	0.04~0.08	0.06~0.08	0.06~0.10	0.06~0.12	0.06~0.12		
				PC5300	70 (30~120)	0.04~0.08	0.06~0.08	0.06~0.10	0.06~0.12	0.06~0.12		
M	Stainless steel	135-275	LD	PD5335	PC5335	120 (80~140)	0.04~0.07	0.04~0.07	0.04~0.07	0.04~0.08	0.04~0.08	
			PD	PC5300	PC5300	130 (100~160)	0.04~0.07	0.04~0.07	0.04~0.07	0.04~0.08	0.04~0.08	
K	Cast iron	Gray cast iron	150~230	PD	PC5300	PC6510	190 (150~250)	0.04~0.12	0.05~0.14	0.06~0.18	0.10~0.22	0.10~0.26
		Ductile cast iron	150~230	PD	PC5300	PC6510	130 (100~160)	0.04~0.07	0.04~0.08	0.04~0.10	0.05~0.12	0.05~0.12
S	Heat resisting alloy	Ni-heat resisting alloy	130~400	PD	PC5300	PC5300	50 (30~100)	0.04~0.10	0.04~0.10	0.04~0.10	0.04~0.10	0.04~0.10
		Ti-heat resisting alloy	130~400	LD	PC5335	PC5335	60 (40~80)	0.04~0.08	0.04~0.10	0.06~0.12	0.06~0.14	0.06~0.16
				PD	PC5300	PC5300	60 (40~80)	0.04~0.08	0.04~0.10	0.06~0.12	0.06~0.14	0.06~0.16
High hardened steel	over 400	PD	PC5300	PC5300	40 (20~80)	0.04~0.05	0.04~0.06	0.04~0.08	0.04~0.08	0.04~0.08		
N	Aluminium	Aluminium	30~150	ND	H01	H01	300 (250~400)	0.05~0.14	0.06~0.16	0.10~0.20	0.10~0.22	0.12~0.25
		Alloyed copper	150-160	ND	H01	H01	250 (200~300)	0.05~0.14	0.06~0.16	0.10~0.20	0.10~0.22	0.12~0.25

- The Max. feed of 5D holders is 70%~80% of the max. conditions of 2D/3D/4D holders
- In interrupted machining part, reduce 30~50% of feed from the above machining around interrupted part

Required cutting power

- The graphs below show the cutting force required in drilling
- Machining with the King Drill and a machine with high rigidity and power

■ **Workpiece** SCM440 (240HB)

■ **Cutting conditions** vc (m/min) = 100, Through coolant system

f_n (mm/rev) = 0.13 f_n (mm/rev) = 0.10 f_n (mm/rev) = 0.07

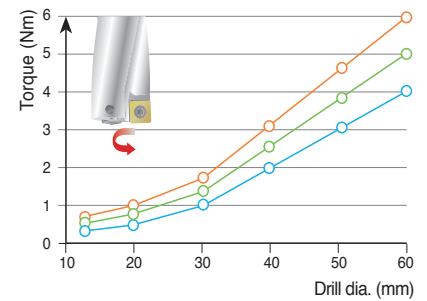
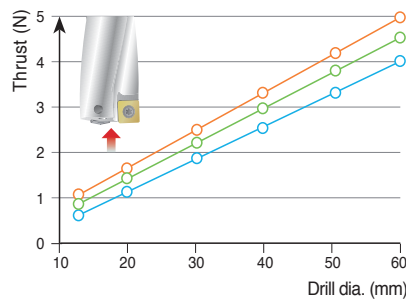
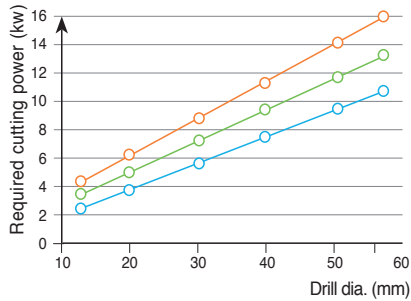

Cutting oil quantity

■ **Workpiece** SCM440 (240HB)

■ **Cutting conditions** vc (m/min) = 100, Through coolant system

- The data of the graph above could be changed depending on workpiece and cutting condition

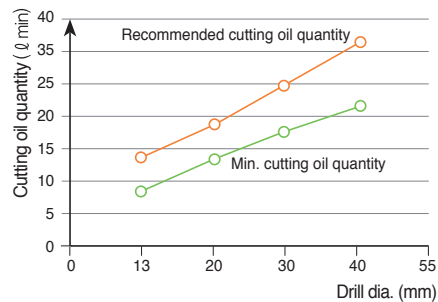

Drill tolerance and hole tolerance

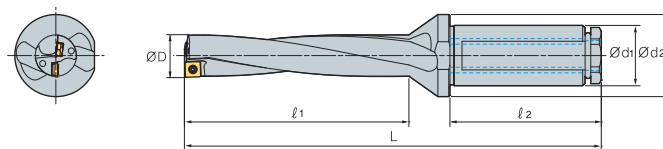

(mm)

Drill dia.		Ø12~Ø29	Ø30~Ø45	Ø46~Ø60.5
2D~3D	Drill tolerance (ØD)	0~-0.15	0~-0.15	0~-0.15
	Hole tolerance	+0.2~-0.1	+0.25~-0.1	+0.28~-0.1
4D~5D	Drill tolerance (ØD)	0~-0.15	0~-0.15	0~-0.15
	Hole tolerance	+0.25~-0.05	+0.3~-0.05	+0.33~-0.05

Notice for setting the drill in the lathe

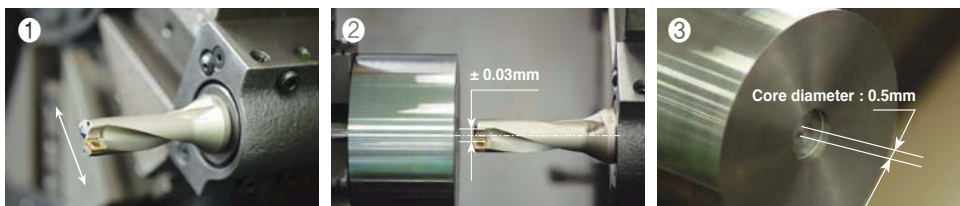

- Set the peripheral insert parallel to the X axis. (based on the side lock)
- If the machined core is 0.5 mm after machining 5 mm, that is the proper setting
- ※ Please make sure that the location of the side lock could be different depending on manufacturers of machine

◀ Range of adjusting machining diameter in the lathe

- In machining in the lathe, the King Drill can extend and reduce the machining diameter by adjusting the x-axis. Please refer to the table showing the range of adjusting drilling diameter below
- The more the drilling diameter is extended or reduced, the more the drill loses drilling balance. In this case, reduce the feed or cutting speed in machining
- Reducing the machining diameter excessively could damage the holder

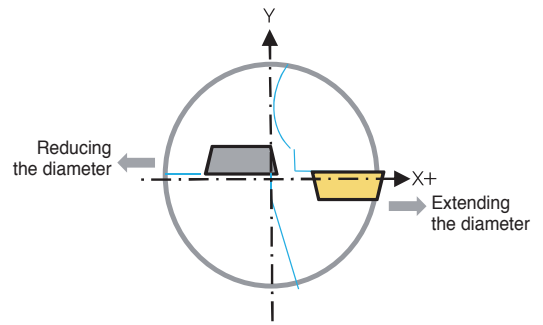

Drill dia. (Ø)	Range of adjusting drilling diameter (Ø)	Drill dia. (Ø)	Range of adjusting drilling diameter (Ø)	Drill dia. (Ø)	Range of adjusting drilling diameter (Ø)	Drill dia. (Ø)	Range of adjusting drilling diameter (Ø)
12.0	11.7~12.4	24.5	23.9~25.1	37.0	36.3~37.7	49.5	48.7~50.2
12.5	12.2~12.9	25.0	24.4~25.6	37.5	36.8~38.2	50.0	49.2~50.7
13.0	12.7~13.4	25.5	24.9~26.1	38.0	37.3~38.7	50.5	49.7~51.2
13.5	13.2~13.9	26.0	25.4~26.6	38.5	37.8~39.2	51.0	50.2~51.7
14.0	13.6~14.5	26.5	25.9~27.1	39.0	38.3~39.7	51.5	50.7~52.2
14.5	14.1~15.0	27.0	26.4~27.6	39.5	38.8~40.2	52.0	51.2~52.7
15.0	14.6~15.5	27.5	26.9~28.1	40.0	39.3~40.7	52.5	51.7~53.2
15.5	15.1~16.0	27.8	27.4~28.6	40.5	39.8~41.2	53.0	52.2~53.7
16.0	15.6~16.5	28.5	27.9~29.1	41.0	40.3~41.7	53.5	52.7~54.2
16.5	16.0~17.0	29.0	28.4~29.6	41.5	40.8~42.2	54.0	53.2~54.7
17.0	16.5~17.5	29.5	28.9~30.1	42.0	41.3~42.7	54.5	53.7~55.2
17.5	17.0~18.0	30.0	29.3~30.7	42.5	41.8~43.2	55.0	54.2~55.7
18.0	17.5~18.5	30.5	29.8~31.2	43.0	42.2~43.7	55.5	54.7~56.2
18.5	18.0~19.0	31.0	30.3~31.7	43.5	42.7~44.2	56.0	55.2~56.7
19.0	18.5~19.5	31.5	30.8~32.2	44.0	43.2~44.7	56.5	55.7~57.2
19.5	19.0~20.0	32.0	31.3~32.7	44.5	43.7~45.2	57.0	56.2~57.7
20.0	19.4~20.6	32.5	31.8~33.2	45.0	44.2~45.7	57.5	56.7~58.2
20.5	19.9~21.1	33.0	32.3~33.7	45.5	44.7~46.2	58.0	57.2~58.7
21.0	20.4~21.6	33.5	32.8~34.2	46.0	45.2~46.7	58.5	57.7~59.2
21.5	20.9~22.1	34.0	33.3~34.7	46.5	45.7~47.2	59.0	58.2~59.7
22.0	21.4~22.6	34.5	33.8~35.2	47.0	46.2~47.7	59.5	58.7~60.2
22.5	21.9~23.1	35.0	34.3~35.7	47.5	46.7~48.2	60.0	59.2~60.7
23.0	22.4~23.6	35.5	34.8~36.2	48.0	47.2~48.7	60.5	59.7~61.2
23.5	22.9~24.1	36.0	35.3~36.7	48.5	47.7~49.2		
24.0	23.4~24.6	36.5	35.8~37.2	49.0	48.2~49.7		

◀ Insert and parts

Drill dia. (mm)	Peripheral insert	Central insert	Screw	Wrench	Torque (N·m)
Ø12.0~Ø13.5	SP□T040204-□□	XO□T040204-□□	FTNA0204	TW06P	0.4
Ø13.6~Ø16.0	SP□T050204-□□	XO□T050204-□□	FTNA0204	TW06P	0.4
Ø16.1~Ø19.5	SP□T060205-□□	XO□T060204-□□	FTKA02206S	TW07P	0.8
Ø19.6~Ø23.5	SP□T07T208-□□	XO□T07T205-□□	FTKA02565	TW07S	0.8
Ø23.6~Ø29.5	SP□T090308-□□	XO□T090305-□□	FTKA0307	TW09S	1.2
Ø29.6~Ø35.5	SP□T11T308-□□	XO□T11T306-□□	FTKA03508	TW15S	3
Ø35.6~Ø42.5	SP□T130410-□□	XO□T130406-□□	FTKA0410	TW15S	3
Ø42.6~Ø50.5	SP□T15M510-□□	XO□T15M508-□□	FTNC04511	TW20S	5
Ø50.6~Ø60.5	SP□T180510-□□	XO□T180508-□□	FTNA0511	TW20-100	5

- In clamping an insert, please clean the tip seat and apply CASMOLY1000 on the screw
- Please make sure to use a Korloy-produced wrench and screw only

G Technical Information for King Drill

King Drill - for machining a tap foundation hole

- There are two types of specifications of tap, metric and inch. The King Drill is available for machining both thru tap and blind tap

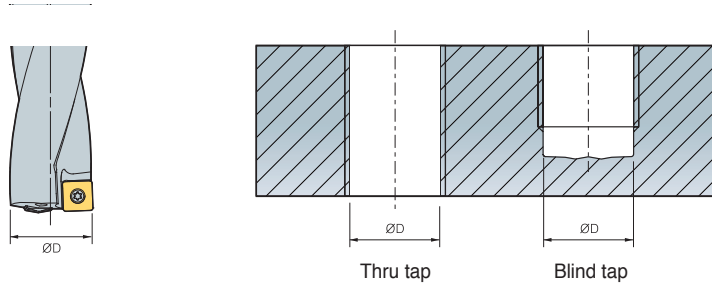

(mm)

Tap type	Thread	ØD	Designation	Reference
Metric	M14 x 2.0	12.0	K3D12020-04	G14
	M16 x 2.0	14.0	K3D14020-05	G14
	M18 x 2.5	15.5	K3D15520-05	G14
	M20 x 2.5	17.5	K3D17525-06	G14
	M22 x 2.5	19.5	K3D19525-06	G14
	M24 x 3.0	21.0	K3D21025-07	G14
	M27 x 3.0	24.0	K3D24032-09	G14
	M30 x 3.5	26.5	K3D26532-09	G14
	M33 x 4.0	29.0	K3D29032-09	G14
	M36 x 4.0	32.0	K3D32032-11	G15
	M39 x 4.0	35.0	K3D35032-11	G15
	M42 x 4.5	37.5	K3D37540-13	G15
Inch	9/16-12 UNC	12.2	K3D12220-04	G14
	5/8-11 UNC	13.5	K3D13520-04	G14
	3/4-10 UNC	16.5	K3D16525-06	G14
	7/8-9 UNC	19.5	K3D19525-06	G14
	9/16-18 UNF	12.9	K3D12920-04	G14
	5/8-18 UNF	14.5	K3D14520-05	G14
	3/4-16 UNF	17.5	K3D17525-06	G14



Special drill order form

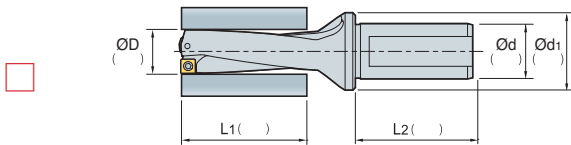
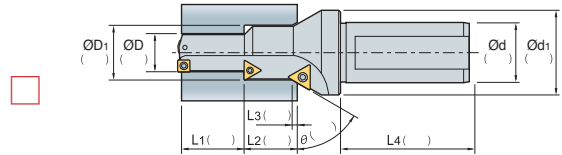
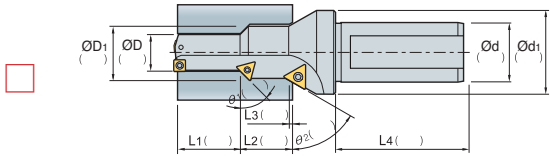
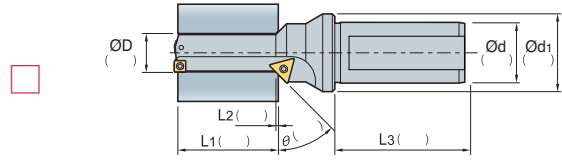
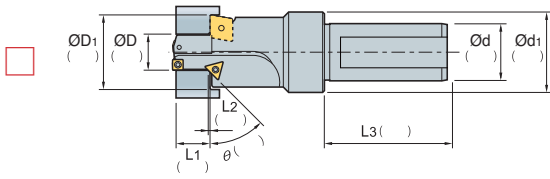

■ Coolant type

Through coolant Plug Type (Standard) Through coolant Non Plug Type No coolant

■ Hole type

Blind hole Thru hole

■ Types of shank

Flat Type

Weldon Type

Whistle Notch Type

■ Location of side lock

Parallel to peripheral insert (standard)

90° angle to peripheral insert (standard)

180° angle to peripheral insert (standard)

270° angle to peripheral insert (standard)



■ Note

- Currently using tool:
- Current cutting condition
 - RPM or vc (m/min):
 - vf (mm/min) or fn (mm/rev):
 - Depth of cut (mm):
- Standard of measuring tool life:
- Currently using machine
 - Machining center:
 - General lathe:
 - CNC lathe:

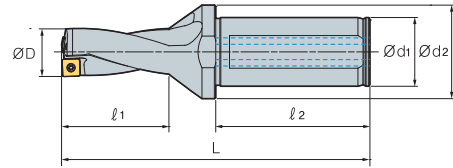
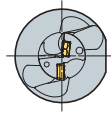
King Drill (2D)



(mm)

Designation	ØD	Ød ₁	Ød ₂	l ₁	l ₂	L	Insert	Screw 	Wrench 
K2D 12020-04	12.0	20	25	27	50	91	SP□T040204-□□ XO□T040204-□□	FTNA0204	TW06P
12520-04	12.5	20	25	27	50	91			
13020-04	13.0	20	25	29	50	93			
13520-04	13.5	20	25	29	50	93	SP□T050204-□□ XO□T050204-□□	FTNA0204	TW06P
14020-05	14.0	20	25	31	50	96			
14520-05	14.5	20	25	31	50	96			
15020-05	15.0	20	25	33	50	99	SP□T060205-□□ XO□T060204-□□	FTKA02206S	TW07P
15520-05	15.5	20	25	33	50	99			
16020-05	16.0	20	25	35	50	101			
16525-06	16.5	25	34	35	56	107	SP□T07T208-□□ XO□T07T205-□□	FTKA02565	TW07S
17025-06	17.0	25	34	37	56	109			
17525-06	17.5	25	34	37	56	109			
18025-06	18.0	25	34	39	56	112	SP□T090308-□□ XO□T090305-□□	FTKA0307	TW09S
18525-06	18.5	25	34	39	56	112			
19025-06	19.0	25	34	41	56	114			
19525-06	19.5	25	34	41	56	114	SP□T11T308-□□ XO□T11T306-□□	FTKA03508	TW15S
20025-07	20.0	25	34	43	56	118			
20525-07	20.5	25	34	43	56	118			
21025-07	21.0	25	34	45	56	120	SP□T11T308-□□ XO□T11T306-□□	FTKA03508	TW15S
21525-07	21.5	25	34	45	56	120			
22025-07	22.0	25	34	47	56	122			
22525-07	22.5	25	34	47	56	122	SP□T11T308-□□ XO□T11T306-□□	FTKA03508	TW15S
23025-07	23.0	25	34	49	56	126			
23525-07	23.5	25	34	49	56	126			
24032-09	24.0	32	44	51	60	133	SP□T11T308-□□ XO□T11T306-□□	FTKA03508	TW15S
24532-09	24.5	32	44	51	60	133			
25032-09	25.0	32	44	53	60	135			
25532-09	25.5	32	44	53	60	135	SP□T11T308-□□ XO□T11T306-□□	FTKA03508	TW15S
26032-09	26.0	32	44	55	60	137			
26532-09	26.5	32	44	55	60	137			
27032-09	27.0	32	44	57	60	140	SP□T11T308-□□ XO□T11T306-□□	FTKA03508	TW15S
27532-09	27.5	32	44	57	60	140			
28032-09	28.0	32	44	59	60	143			
28532-09	28.5	32	44	59	60	143	SP□T11T308-□□ XO□T11T306-□□	FTKA03508	TW15S
29032-09	29.0	32	44	61	60	145			
29532-09	29.5	32	44	61	60	145			
30032-11	30.0	32	44	63	60	150	SP□T11T308-□□ XO□T11T306-□□	FTKA03508	TW15S
30532-11	30.5	32	44	63	60	150			
31032-11	31.0	32	44	65	60	152			
31532-11	31.5	32	44	65	60	152	SP□T11T308-□□ XO□T11T306-□□	FTKA03508	TW15S
32032-11	32.0	32	44	67	60	154			
32532-11	32.5	32	44	67	60	154			
33032-11	33.0	32	44	69	60	157	SP□T11T308-□□ XO□T11T306-□□	FTKA03508	TW15S
33532-11	33.5	32	44	69	60	157			
34032-11	34.0	32	44	71	60	159			
34532-11	34.5	32	44	71	60	159	SP□T11T308-□□ XO□T11T306-□□	FTKA03508	TW15S
35032-11	35.0	32	44	73	60	161			
35532-11	35.5	32	44	73	60	161			

↻ Applicable inserts G04~05



King Drill (2D)

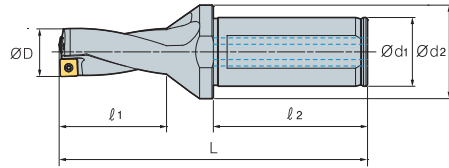
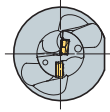



Designation		ØD	Ød ₁	Ød ₂	l ₁	l ₂	L	Insert	Screw	Wrench
K2D	36040-13	36.0	40	48	76	70	176	SP□T130410-□□ XO□T130406-□□	FTKA0410	TW15S
	36540-13	36.5	40	48	76	70	176			
	37040-13	37.0	40	48	78	70	178			
	37540-13	37.5	40	48	78	70	178			
	38040-13	38.0	40	48	80	70	181			
	38540-13	38.5	40	48	80	70	181			
	39040-13	39.0	40	48	82	70	183			
	39540-13	39.5	40	48	82	70	183			
	40040-13	40.0	40	48	84	70	186			
	40540-13	40.5	40	48	84	70	186			
	41040-13	41.0	40	48	86	70	188			
	41540-13	41.5	40	48	86	70	188			
	42040-13	42.0	40	48	88	70	191			
	42540-13	42.5	40	48	88	70	191			
	43040-15	43.0	40	58	91	70	196			
	43540-15	43.5	40	58	91	70	196			
	44040-15	44.0	40	58	93	70	198			
	44540-15	44.5	40	58	93	70	198			
	45040-15	45.0	40	58	95	70	201			
	45540-15	45.5	40	58	95	70	201			
	46040-15	46.0	40	58	97	70	203			
	46540-15	46.5	40	58	97	70	203			
	47040-15	47.0	40	58	99	70	206			
	47540-15	47.5	40	58	99	70	206			
	48040-15	48.0	40	58	101	70	208			
	48540-15	48.5	40	58	101	70	208			
	49040-15	49.0	40	58	103	70	210			
	49540-15	49.5	40	58	103	70	210			
	50040-15	50.0	40	58	105	70	212			
	50540-15	50.5	40	58	105	70	212			
	51040-18	51.0	40	68	108	70	218			
	51540-18	51.5	40	68	108	70	218			
	52040-18	52.0	40	68	110	70	220			
52540-18	52.5	40	68	110	70	220				
53040-18	53.0	40	68	112	70	222				
53540-18	53.5	40	68	112	70	222				
54040-18	54.0	40	68	114	70	224				
54540-18	54.5	40	68	114	70	224				
55040-18	55.0	40	68	116	70	226				
55540-18	55.5	40	68	116	70	226				
56040-18	56.0	40	68	118	70	230				
56540-18	56.5	40	68	118	70	230				
57040-18	57.0	40	68	121	70	233				
57540-18	57.5	40	68	121	70	233				
58040-18	58.0	40	68	124	70	236				
58540-18	58.5	40	68	124	70	236				
59040-18	59.0	40	68	127	70	239				
59540-18	59.5	40	68	127	70	239				
60040-18	60.0	40	68	130	70	242				
60540-18	60.5	40	68	130	70	242				

↻ Applicable inserts G04-05

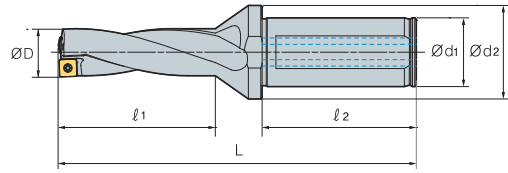
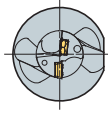
King Drill (3D)



(mm)

Designation	ØD	Ød ₁	Ød ₂	l ₁	l ₂	L	Insert	Screw 	Wrench 
K3D 12020-04 *	12.0	20	25	39	50	103	SP□T040204-□□ XO□T040204-□□	FTNA0204	TW06P
12220-04	12.2	20	25	39	50	103			
12520-04	12.5	20	25	39	50	103			
12920-04	12.9	20	25	42	50	106			
13020-04	13.0	20	25	42	50	106			
13520-04	13.5	20	25	42	50	106			
14020-05 *	14.0	20	25	45	50	110	SP□T050204-□□ XO□T050204-□□	FTNA0204	TW06P
14520-05	14.5	20	25	45	50	110			
15020-05	15.0	20	25	48	50	114			
15520-05 *	15.5	20	25	48	50	114			
16020-05	16.0	20	25	51	50	117			
16525-06	16.5	25	34	51	56	123			
17025-06	17.0	25	34	54	56	126			
17525-06 *	17.5	25	34	54	56	126			
18025-06	18.0	25	34	57	56	130			
18525-06	18.5	25	34	57	56	130			
19025-06	19.0	25	34	60	56	133	SP□T07T208-□□ XO□T07T205-□□	FTKA02565	TW07S
19525-06 *	19.5	25	34	60	56	133			
20025-07	20.0	25	34	63	56	138			
20525-07	20.5	25	34	63	56	138			
21025-07 *	21.0	25	34	66	56	141			
21525-07	21.5	25	34	66	56	141			
22025-07	22.0	25	34	69	56	144	SP□T090308-□□ XO□T090305-□□	FTKA0307	TW09S
22525-07	22.5	25	34	69	56	144			
23025-07	23	25	34	72	56	149			
23525-07	23.5	25	34	72	56	149			
24032-09 *	24.0	32	44	75	60	157			
24532-09	24.5	32	44	75	60	157			
25032-09	25.0	32	44	78	60	160	SP□T090308-□□ XO□T090305-□□	FTKA0307	TW09S
25532-09	25.5	32	44	78	60	160			
26032-09	26.0	32	44	81	60	163			
26532-09 *	26.5	32	44	81	60	163			
27032-09	27.0	32	44	84	60	167			
27532-09	27.5	32	44	84	60	167			
28032-09	28.0	32	44	87	60	171	SP□T090308-□□ XO□T090305-□□	FTKA0307	TW09S
28532-09	28.5	32	44	87	60	171			
29032-09 *	29.0	32	44	90	60	174			
29532-09	29.5	32	44	90	60	174			



↻ Applicable inserts G04-05

The items marked * can machine a tap foundation hole (Reference G09p)

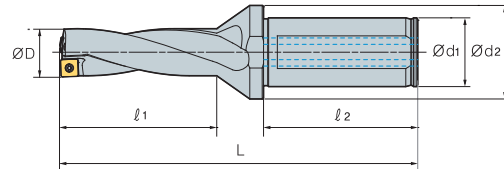
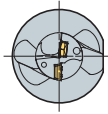

King Drill (3D)



Designation		ØD	Ød ₁	Ød ₂	l ₁	l ₂	L	Insert	Screw 	Wrench 			
K3D	30032-11 *	30.0	32	44	93	60	180	SP□T11T308-□□ XO□T11T306-□□	FTKA03508	TW15S			
	30532-11	30.5	32	44	93	60	180						
	31032-11	31.0	32	44	96	60	183						
	31532-11	31.5	32	44	96	60	183						
	32032-11	32.0	32	44	99	60	186						
	32532-11	32.5	32	44	99	60	186						
	33032-11	33.0	32	44	102	60	190						
	33532-11	33.5	32	44	102	60	190						
	34032-11	34.0	32	44	105	60	193						
	34532-11	34.5	32	44	105	60	193						
	35032-11 *	35.0	32	44	108	60	196						
	35532-11	35.5	32	44	108	60	196						
	36040-13	36.0	40	48	112	70	212				SP□T130410-□□ XO□T130406-□□	FTKA0410	TW15S
	36540-13	36.5	40	48	112	70	212						
	37040-13	37.0	40	48	115	70	215						
	37540-13	37.5	40	48	115	70	215						
	38040-13	38.0	40	48	118	70	219						
	38540-13	38.5	40	48	118	70	219						
	39040-13	39.0	40	48	121	70	222						
	39540-13	39.5	40	48	121	70	222						
	40040-13	40.0	40	48	124	70	226						
	40540-13	40.5	40	48	124	70	226						
41040-13	41.0	40	48	127	70	229							
41540-13	41.5	40	48	127	70	229							
42040-13	42.0	40	48	130	70	233	SP□T15M510-□□ XO□T15M508-□□	FTNC04511	TW20S				
42540-13	42.5	40	48	130	70	233							
43040-15	43.0	40	58	134	70	239							
43540-15	43.5	40	58	134	70	239							
44040-15	44.0	40	58	137	70	242							
44540-15	44.5	40	58	137	70	242							
45040-15	45.0	40	58	140	70	246							
45540-15	45.5	40	58	140	70	246							
46040-15	46.0	40	58	143	70	249							
46540-15	46.5	40	58	143	70	249							
47040-15	47.0	40	58	146	70	253							
47540-15	47.5	40	58	146	70	253							
48040-15	48.0	40	58	149	70	256							
48540-15	48.5	40	58	149	70	256							
49040-15	49.0	40	58	152	70	259							
49540-15	49.5	40	58	152	70	259							
50040-15	50.0	40	58	155	70	262							
50540-15	50.5	40	58	155	70	262							

↻ Applicable inserts G04-05

The items marked * can machine a tap foundation hole (Reference G09p)

King Drill (3D)

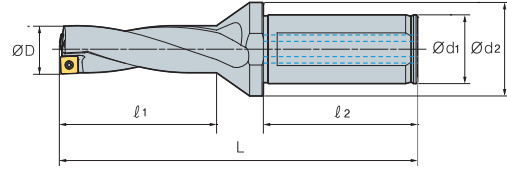
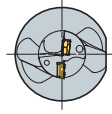

(mm)

Designation	ØD	Ød ₁	Ød ₂	l ₁	l ₂	L	Insert	Screw	Wrench
K3D									
51040-18	51.0	40	68	159	70	269			
51540-18	51.5	40	68	159	70	269			
52040-18	52.0	40	68	162	70	272			
52540-18	52.5	40	68	162	70	272			
53040-18	53.0	40	68	165	70	275			
53540-18	53.5	40	68	165	70	275			
54040-18	54.0	40	68	168	70	278			
54540-18	54.5	40	68	168	70	278			
55040-18	55.0	40	68	171	70	281			
55540-18	55.5	40	68	171	70	281	SP□T180510-□□	FTNA0511	TW20-100
56040-18	56.0	40	68	174	70	286	XO□T180508-□□		
56540-18	56.5	40	68	174	70	286			
57040-18	57.0	40	68	178	70	290			
57540-18	57.5	40	68	178	70	290			
58040-18	58.0	40	68	182	70	294			
58540-18	58.5	40	68	182	70	294			
59040-18	59.0	40	68	186	70	298			
59540-18	59.5	40	68	186	70	298			
60040-18	60.0	40	68	190	70	302			
60540-18	60.5	40	68	190	70	302			

↻ Applicable inserts G04~05

King Drill (4D)

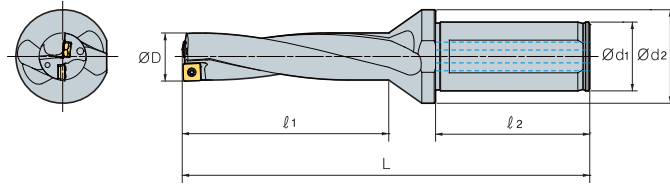

Designation		ØD	Ød ₁	Ød ₂	l ₁	l ₂	L	Insert	Screw	Wrench
K4D	12020-04	12.0	20	25	51	50	115	SP□T040204-□□ XO□T040204-□□	FTNA0204	TW06P
	12520-04	12.5	20	25	51	50	115			
	13020-04	13.0	20	25	55	50	119			
	13520-04	13.5	20	25	55	50	119			
	14020-05	14.0	20	25	59	50	124	SP□T050204-□□ XO□T050204-□□	FTNA0204	TW06P
	14520-05	14.5	20	25	59	50	124			
	15020-05	15.0	20	25	63	50	129			
	15520-05	15.5	20	25	63	50	129			
	16020-05	16.0	20	25	67	50	133	SP□T060205-□□ XO□T060204-□□	FTKA02206S	TW07P
	16525-06	16.5	25	34	67	56	139			
	17025-06	17.0	25	34	71	56	143			
	17525-06	17.5	25	34	71	56	143			
	18025-06	18.0	25	34	75	56	148			
	18525-06	18.5	25	34	75	56	148			
	19025-06	19.0	25	34	79	56	152			
	19525-06	19.5	25	34	79	56	152			
	20025-07	20.0	25	34	83	56	158	SP□T07T208-□□ XO□T07T205-□□	FTKA02565	TW07S
	20525-07	20.5	25	34	83	56	158			
	21025-07	21.0	25	34	87	56	162			
	21525-07	21.5	25	34	87	56	162			
	22025-07	22.0	25	34	91	56	166			
	22525-07	22.5	25	34	91	56	166			
	23025-07	23.0	25	34	95	56	172			
	23525-07	23.5	25	34	95	56	172			
	24032-09	24.0	32	44	99	60	181	SP□T090308-□□ XO□T090305-□□	FTKA0307	TW09S
	24532-09	24.5	32	44	99	60	181			
	25032-09	25.0	32	44	103	60	185			
	25532-09	25.5	32	44	103	60	185			
	26032-09	26.0	32	44	107	60	189			
	26532-09	26.5	32	44	107	60	189			
	27032-09	27.0	32	44	111	60	194			
	27532-09	27.5	32	44	111	60	194			
	28032-09	28.0	32	44	115	60	199			
	28532-09	28.5	32	44	115	60	199			
	29032-09	29.0	32	44	119	60	203			
	29532-09	29.5	32	44	119	60	203			
	30032-11	30.0	32	44	123	60	210	SP□T11T308-□□ XO□T11T306-□□	FTKA03508	TW15S
	30532-11	30.5	32	44	123	60	210			
	31032-11	31.0	32	44	127	60	214			
	31532-11	31.5	32	44	127	60	214			
32032-11	32.0	32	44	131	60	218				
32532-11	32.5	32	44	131	60	218				
33032-11	33.0	32	44	135	60	223				
33532-11	33.5	32	44	135	60	223				
34032-11	34.0	32	44	139	60	227				
34532-11	34.5	32	44	139	60	227				
35032-11	35.0	32	44	143	60	231				
35532-11	35.5	32	44	143	60	231				

↻ Applicable inserts G04-05

King Drill (4D)

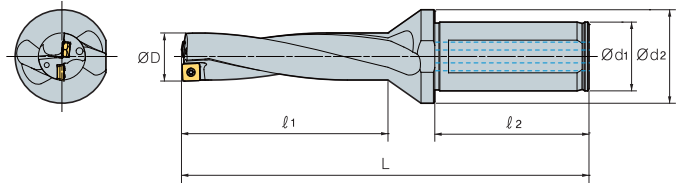

(mm)

Designation	ØD	Ød ₁	Ød ₂	l ₁	l ₂	L	Insert	Screw	Wrench
K4D									
36040-13	36.0	40	48	148	70	248	SP□T130410-□□ XO□T130406-□□	FTKA0410	TW15S
36540-13	36.5	40	48	148	70	248			
37040-13	37.0	40	48	152	70	252			
37540-13	37.5	40	48	152	70	252			
38040-13	38.0	40	48	156	70	257			
38540-13	38.5	40	48	156	70	257			
39040-13	39.0	40	48	160	70	261			
39540-13	39.5	40	48	160	70	261			
40040-13	40.0	40	48	164	70	266			
40540-13	40.5	40	48	164	70	266			
41040-13	41.0	40	48	168	70	270			
41540-13	41.5	40	48	168	70	270			
42040-13	42.0	40	48	172	70	275			
42540-13	42.5	40	48	172	70	275			
43040-15	43.0	40	58	177	70	282			
43540-15	43.5	40	58	177	70	282			
44040-15	44.0	40	58	181	70	286			
44540-15	44.5	40	58	181	70	286			
45040-15	45.0	40	58	185	70	291			
45540-15	45.5	40	58	185	70	291			
46040-15	46.0	40	58	189	70	295			
46540-15	46.5	40	58	189	70	295			
47040-15	47.0	40	58	193	70	300			
47540-15	47.5	40	58	193	70	300			
48040-15	48.0	40	58	197	70	304			
48540-15	48.5	40	58	197	70	304			
49040-15	49.0	40	58	201	70	308			
49540-15	49.5	40	58	201	70	308			
50040-15	50.0	40	58	205	70	312			
50540-15	50.5	40	58	205	70	312			
51040-18	51.0	40	68	210	70	320			
51540-18	51.5	40	68	210	70	320			
52040-18	52.0	40	68	214	70	324			
52540-18	52.5	40	68	214	70	324			
53040-18	53.0	40	68	218	70	328			
53540-18	53.5	40	68	218	70	328			
54040-18	54.0	40	68	222	70	332			
54540-18	54.5	40	68	222	70	332			
55040-18	55.0	40	68	226	70	336			
55540-18	55.5	40	68	226	70	336			
56040-18	56.0	40	68	230	70	342			
56540-18	56.5	40	68	230	70	342			
57040-18	57.0	40	68	235	70	347			
57540-18	57.5	40	68	235	70	347			
58040-18	58.0	40	68	240	70	352			
58540-18	58.5	40	68	240	70	352			
59040-18	59.0	40	68	245	70	357			
59540-18	59.5	40	68	245	70	357			
60040-18	60.0	40	68	250	70	362			
60540-18	60.5	40	68	250	70	362			
							SP□T15M510-□□ XO□T15M508-□□	FTNC04511	TW20S
							SP□T180510-□□ XO□T180508-□□	FTNA0511	TW20-100

↻ Applicable inserts G04~05



King Drill (5D)

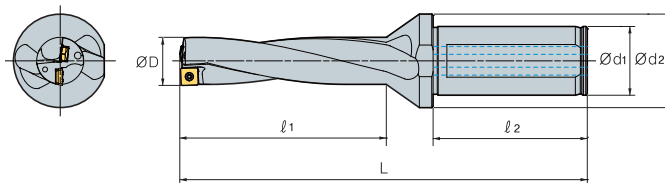



Designation		ØD	Ød ₁	Ød ₂	l ₁	l ₂	L	Insert	Screw	Wrench
K5D	12020-04	12.0	20	25	63	50	127	SP□T040204-□□ XO□T040204-□□	FTNA0204	TW06P
	12520-04	12.5	20	25	63	50	127			
	13020-04	13.0	20	25	68	50	132	SP□T050204-□□ XO□T050204-□□	FTNA0204	TW06P
	13520-04	13.5	20	25	68	50	132			
	14020-05	14.0	20	25	73	50	138	SP□T060205-□□ XO□T060204-□□	FTKA02206S	TW07P
	14520-05	14.5	20	25	73	50	138			
	15020-05	15.0	20	25	78	50	144	SP□T07T208-□□ XO□T07T205-□□	FTKA02565	TW07S
	15520-05	15.5	20	25	78	50	144			
	16020-05	16.0	20	25	83	50	149	SP□T090308-□□ XO□T090305-□□	FTKA0307	TW09S
	16525-06	16.5	25	34	83	56	155			
	17025-06	17.0	25	34	88	56	160	SP□T11T308-□□ XO□T11T306-□□	FTKA03508	TW15S
	17525-06	17.5	25	34	88	56	160			
	18025-06	18.0	25	34	93	56	166	SP□T11T308-□□ XO□T11T306-□□	FTKA03508	TW15S
	18525-06	18.5	25	34	93	56	166			
	19025-06	19.0	25	34	98	56	171	SP□T11T308-□□ XO□T11T306-□□	FTKA03508	TW15S
	19525-06	19.5	25	34	98	56	171			
	20025-07	20.0	25	34	103	56	178	SP□T11T308-□□ XO□T11T306-□□	FTKA03508	TW15S
	20525-07	20.5	25	34	103	56	178			
	21025-07	21.0	25	34	108	56	183	SP□T11T308-□□ XO□T11T306-□□	FTKA03508	TW15S
	21525-07	21.5	25	34	108	56	183			
	22025-07	22.0	25	34	113	56	188	SP□T11T308-□□ XO□T11T306-□□	FTKA03508	TW15S
	22525-07	22.5	25	34	113	56	188			
	23025-07	23.0	25	34	118	56	195	SP□T11T308-□□ XO□T11T306-□□	FTKA03508	TW15S
	23525-07	23.5	25	34	118	56	195			
	24032-09	24.0	32	44	123	60	205	SP□T11T308-□□ XO□T11T306-□□	FTKA03508	TW15S
	24532-09	24.5	32	44	123	60	205			
	25032-09	25.0	32	44	128	60	210	SP□T11T308-□□ XO□T11T306-□□	FTKA03508	TW15S
	25532-09	25.5	32	44	128	60	210			
	26032-09	26.0	32	44	133	60	215	SP□T11T308-□□ XO□T11T306-□□	FTKA03508	TW15S
	26532-09	26.5	32	44	133	60	215			
	27032-09	27.0	32	44	138	60	221	SP□T11T308-□□ XO□T11T306-□□	FTKA03508	TW15S
	27532-09	27.5	32	44	138	60	221			
	28032-09	28.0	32	44	143	60	227	SP□T11T308-□□ XO□T11T306-□□	FTKA03508	TW15S
	28532-09	28.5	32	44	143	60	227			
	29032-09	29.0	32	44	148	60	232	SP□T11T308-□□ XO□T11T306-□□	FTKA03508	TW15S
29532-09	29.5	32	44	148	60	232				
30032-11	30.0	32	44	153	60	240	SP□T11T308-□□ XO□T11T306-□□	FTKA03508	TW15S	
30532-11	30.5	32	44	153	60	240				
31032-11	31.0	32	44	158	60	245	SP□T11T308-□□ XO□T11T306-□□	FTKA03508	TW15S	
31532-11	31.5	32	44	158	60	245				
32032-11	32.0	32	44	163	60	250	SP□T11T308-□□ XO□T11T306-□□	FTKA03508	TW15S	
32532-11	32.5	32	44	163	60	250				
33032-11	33.0	32	44	168	60	256	SP□T11T308-□□ XO□T11T306-□□	FTKA03508	TW15S	
33532-11	33.5	32	44	168	60	256				
34032-11	34.0	32	44	173	60	261	SP□T11T308-□□ XO□T11T306-□□	FTKA03508	TW15S	
34532-11	34.5	32	44	173	60	261				
35032-11	35.0	32	44	178	60	266	SP□T11T308-□□ XO□T11T306-□□	FTKA03508	TW15S	
35532-11	35.5	32	44	178	60	266				

→ Applicable inserts G04-05

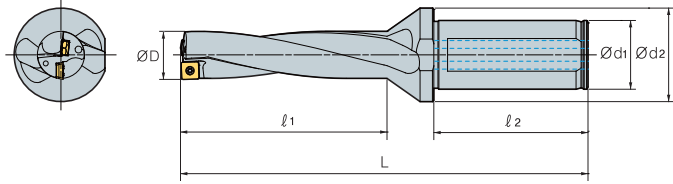
King Drill (5D)



(mm)

Designation	ØD	Ød ₁	Ød ₂	l ₁	l ₂	L	Insert	Screw 	Wrench 
K5D									
36040-13	36.0	40	48	184	70	284	SP□T130410-□□ XO□T130406-□□	FTKA0410	TW15S
36540-13	36.5	40	48	184	70	284			
37040-13	37.0	40	48	189	70	289			
37540-13	37.5	40	48	189	70	289			
38040-13	38.0	40	48	194	70	295			
38540-13	38.5	40	48	194	70	295			
39040-13	39.0	40	48	199	70	300			
39540-13	39.5	40	48	199	70	300			
40040-13	40.0	40	48	204	70	306			
40540-13	40.5	40	48	204	70	306			
41040-13	41.0	40	48	209	70	311			
41540-13	41.5	40	48	209	70	311			
42040-13	42.0	40	48	214	70	317			
42540-13	42.5	40	48	214	70	317			
43040-15	43.0	40	58	220	70	325	SP□T15M510-□□ XO□T15M508-□□	FTNC04511	TW20S
43540-15	43.5	40	58	221	70	326			
44040-15	44.0	40	58	225	70	330			
44540-15	44.5	40	58	225	70	330			
45040-15	45.0	40	58	230	70	336			
45540-15	45.5	40	58	230	70	336			
46040-15	46.0	40	58	235	70	341			
46540-15	46.5	40	58	235	70	341			
47040-15	47.0	40	58	240	70	347			
47540-15	47.5	40	58	240	70	347			
48040-15	48.0	40	58	245	70	352			
48540-15	48.5	40	58	245	70	352			
49040-15	49.0	40	58	250	70	357			
49540-15	49.5	40	58	250	70	357			
50040-15	50.0	40	58	255	70	362	SP□T180510-□□ XO□T180508-□□	FTNA0511	TW20-100
50540-15	50.5	40	58	255	70	362			
51040-18	51.0	40	68	261	70	371			
51540-18	51.5	40	68	261	70	371			
52040-18	52.0	40	68	266	70	376			
52540-18	52.5	40	68	266	70	376			
53040-18	53.0	40	68	271	70	381			
53540-18	53.5	40	68	271	70	381			
54040-18	54.0	40	68	276	70	386			
54540-18	54.5	40	68	276	70	386			
55040-18	55.0	40	68	281	70	391			
55540-18	55.5	40	68	281	70	391			
56040-18	56.0	40	68	286	70	398			
56540-18	56.5	40	68	286	70	398			
57040-18	57.0	40	68	292	70	404			
57540-18	57.5	40	68	292	70	404			
58040-18	58.0	40	68	298	70	410			
58540-18	58.5	40	68	298	70	410			
59040-18	59.0	40	68	304	70	416			
59540-18	59.5	40	68	304	70	416			
60040-18	60.0	40	68	310	70	422			
60540-18	60.5	40	68	310	70	422			

↻ Applicable inserts G04~05



Drill with through coolant system for general lathe and
CNC lathe without through coolant system

King Drill (For through coolant system with a lathe)

- Through coolant system with drill holder, plug, oil-hole hose and oil-hole pump
- PT TAP in the plug is combined to PT TAP connected to oil hose
- Available to use the drill without a plug in milling machine

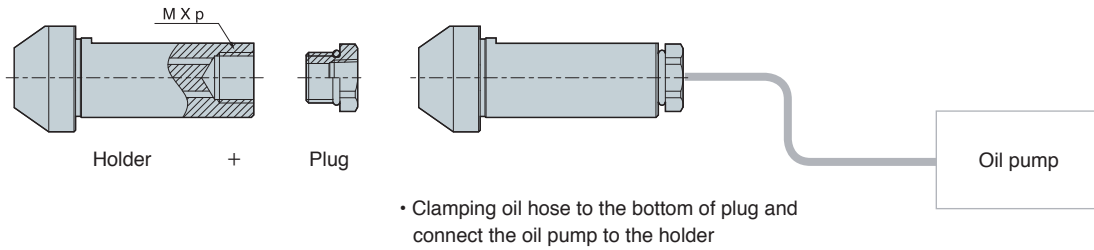

Tap type	Diameter	Shank dia.	M x p	Plug
K□D120~16020HP-□□	Ø12.0~Ø16.0	Ø20	M12x1.5	PLG12PT18
K□D161~23525HP-□□	Ø16.1~Ø23.5	Ø25	M16x1.5	PLG16PT18
K□D236~35532HP-□□	Ø23.6~Ø35.5	Ø32	M20x2.0	PLG20PT14
K□D356~60940HP-□□	Ø35.6~Ø60.5	Ø40	M27x2.0	PLG27PT38

(mm)

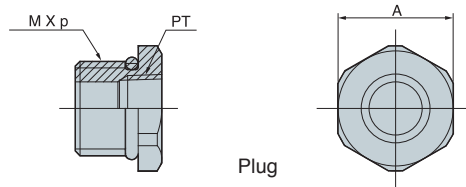

• Plug is assembled

Plug type	M x p	PT tap	A
PLG12PT18	M12x1.5	1/8	16
PLG16PT18	M16x1.5	1/8	19
PLG20PT14	M20x2.0	1/4	26
PLG27PT38	M27x2.0	3/8	35

King Drill (2D)

For through coolant system with a lathe

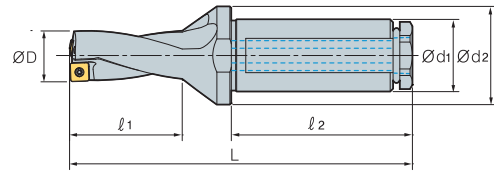
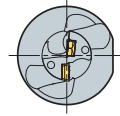

(mm)

Designation	ØD	Ød ₁	Ød ₂	l ₁	l ₂	L	Insert	Screw	Wrench
K2D 13020HP-04	13.0	20	25	29	50	93	SP□T040204-□□	FTNA0204	TW06P
	13.5	20	25	29	50	93	XO□T040204-□□		
14020HP-05	14.0	20	25	31	50	96	SP□T050204-□□ XO□T050204-□□	FTNA0204	TW06P
15020HP-05	15.0	20	25	33	50	99			
16020HP-05	16.0	20	25	35	50	101	SP□T060205-□□ XO□T060204-□□	FTKA02206S	TW07P
17025HP-06	17.0	25	34	37	56	109			
18025HP-06	18.0	25	34	39	56	112	SP□T07T208-□□ XO□T07T205-□□	FTKA02565	TW07S
19025HP-06	19.0	25	34	41	56	114			
20025HP-07	20.0	25	34	43	56	118	SP□T090308-□□ XO□T090305-□□	FTKA0307	TW09S
21025HP-07	21.0	25	34	45	56	120			
22025HP-07	22.0	25	34	47	56	122	SP□T090308-□□ XO□T090305-□□	FTKA0307	TW09S
23025HP-07	23.0	25	34	49	56	126			
24032HP-09	24.0	32	44	51	60	133	SP□T090308-□□ XO□T090305-□□	FTKA0307	TW09S
25032HP-09	25.0	32	44	53	60	135			
26032HP-09	26.0	32	44	55	60	137	SP□T090308-□□ XO□T090305-□□	FTKA0307	TW09S
27032HP-09	27.0	32	44	57	60	140			
28032HP-09	28.0	32	44	59	60	143	SP□T090308-□□ XO□T090305-□□	FTKA0307	TW09S
29032HP-09	29.0	32	44	61	60	145			

Applicable inserts G04~05

King Drill (3D)

For through coolant system with a lathe

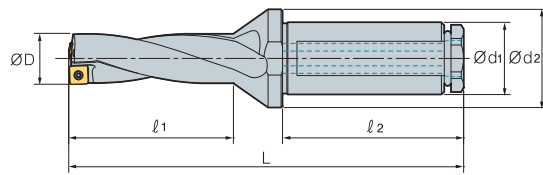
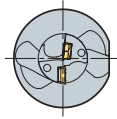

Designation		ØD	Ød ₁	Ød ₂	l ₁	l ₂	L	Insert	Screw	Wrench
K3D	13020HP-04	13.0	20	25	42	50	106	SP□T040204-□□ XO□T040204-□□	FTNA0204	TW06P
	13520HP-04	13.5	20	25	42	50	106			
	14020HP-05	14.0	20	25	45	50	110			
	14520HP-05	14.5	20	25	45	50	110		FTNA0204	TW06P
	15020HP-05	15.0	20	25	48	50	114	SP□T050204-□□ XO□T050204-□□		
	15520HP-05	15.5	20	25	48	50	114			
	16020HP-05	16.0	20	25	51	50	117			
	16525HP-06	16.5	25	34	51	56	123			
	17025HP-06	17.0	25	34	54	56	126			
	17525HP-06	17.5	25	34	54	56	126		FTKA02206S	TW07P
	18025HP-06	18.0	25	34	57	56	130	SP□T060205-□□ XO□T060204-□□		
	18525HP-06	18.5	25	34	57	56	130			
	19025HP-06	19.0	25	34	60	56	133			
	19525HP-06	19.5	25	34	60	56	133			
	20025HP-07	20.0	25	34	63	56	138			
	20525HP-07	20.5	25	34	63	56	138		FTKA02565	TW07S
	21025HP-07	21.0	25	34	66	56	141			
	21525HP-07	21.5	25	34	66	56	141	SP□T07T208-□□ XO□T07T205-□□		
	22025HP-07	22.0	25	34	69	56	144			
	22525HP-07	22.5	25	34	69	56	144			
	23025HP-07	23.0	25	34	72	56	149			
	23525HP-07	23.5	25	34	72	56	149			
	24032HP-09	24.0	32	44	75	60	157			
	24532HP-09	24.5	32	44	75	60	157		FTKA0307	TW09S
	25032HP-09	25.0	32	44	78	60	160			
	25532HP-09	25.5	32	44	78	60	160			
	26032HP-09	26.0	32	44	81	60	163			
	26532HP-09	26.5	32	44	81	60	163	SP□T090308-□□ XO□T090305-□□		
	27032HP-09	27.0	32	44	84	60	167			
	27532HP-09	27.5	32	44	84	60	167			
	28032HP-09	28.0	32	44	87	60	171			
	28532HP-09	28.5	32	44	87	60	171			
29032HP-09	29.0	32	44	90	60	174				
29532HP-09	29.5	32	44	90	60	174				

↻ Applicable inserts G04-05

King Drill (4D)

For through coolant system with a lathe

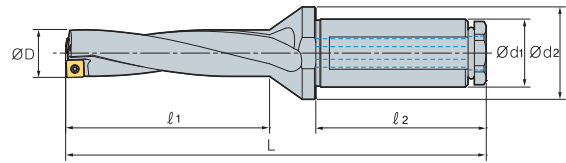
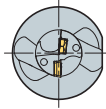

(mm)

Designation	ØD	Ød ₁	Ød ₂	l ₁	l ₂	L	Insert	Screw	Wrench
K4D 13020HP-04	13.0	20	25	29	50	93	SP□T040204-□□	FTNA0204	TW06P
	13.5	20	25	29	50	93	XO□T040204-□□		
14020HP-05	14.0	20	25	59	50	124	SP□T050204-□□ XO□T050204-□□	FTNA0204	TW06P
15020HP-05	15.0	20	25	63	50	129			
16020HP-05	16.0	20	25	67	50	133	SP□T060205-□□ XO□T060204-□□	FTKA02206S	TW07P
17025HP-06	17.0	25	34	71	56	143			
18025HP-06	18.0	25	34	75	56	148	SP□T07T208-□□ XO□T07T205-□□	FTKA02565	TW07S
19025HP-06	19.0	25	34	79	56	152			
20025HP-07	20.0	25	34	83	56	158	SP□T090308-□□ XO□T090305-□□	FTKA0307	TW09S
21025HP-07	21.0	25	34	87	56	162			
22025HP-07	22.0	25	34	91	56	166	SP□T090308-□□ XO□T090305-□□	FTKA0307	TW09S
23025HP-07	23.0	25	34	95	56	172			
24032HP-09	24.0	32	44	99	60	181	SP□T090308-□□ XO□T090305-□□	FTKA0307	TW09S
25032HP-09	25.0	32	44	103	60	185			
26032HP-09	26.0	32	44	107	60	189	SP□T090308-□□ XO□T090305-□□	FTKA0307	TW09S
27032HP-09	27.0	32	44	111	60	194			
28032HP-09	28.0	32	44	115	60	199	SP□T090308-□□ XO□T090305-□□	FTKA0307	TW09S
29032HP-09	29.0	32	44	119	60	203			

↻ Applicable inserts G04~05

High rigidity drill produces cost efficiency due to cartridge replacement

King Drill (For large diameter drilling)

- Cartridge type for $\varnothing 61 \sim \varnothing 100$ drilling
- Peripheral cartridge can adjust the drilling diameter within 5 mm
- Easy to adjust drilling diameter with adjusting bolt

Structure of King Drill (for large diameter) parts

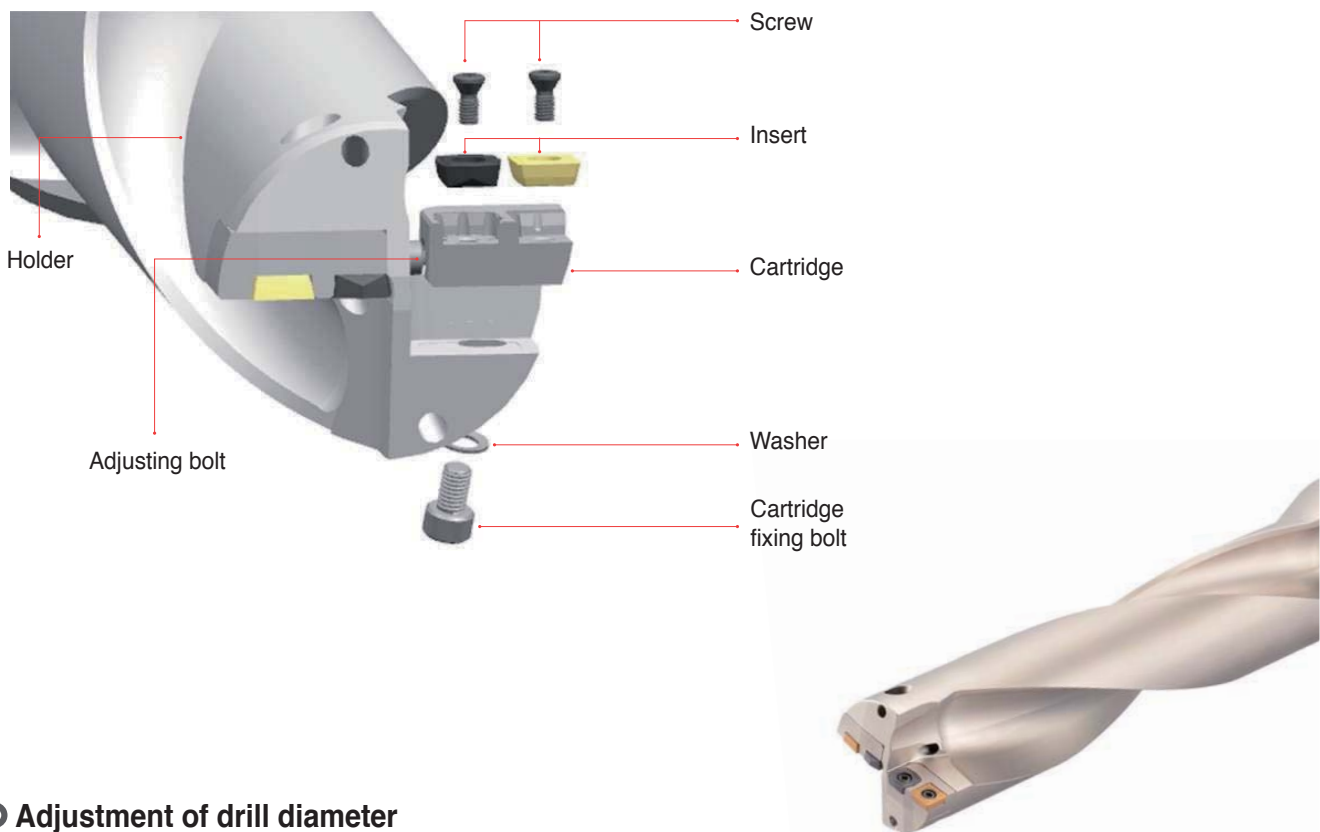

Adjustment of drill diameter

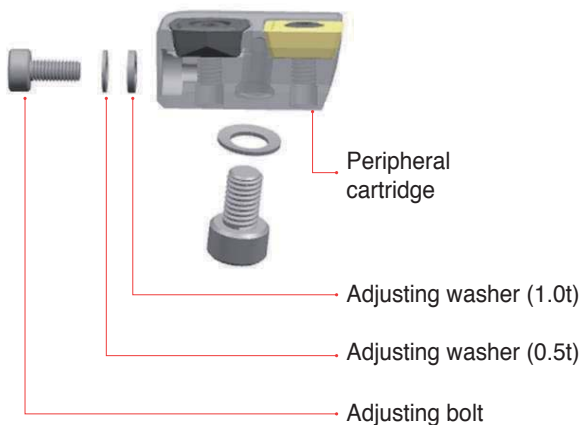

Adjustment \varnothing (mm)	Adjusting washer	
	Designation	Width (mm)
1	WA0305	0.5
2	WA0310	1.0
3	WA0305+WA0310	1.5
4	WA0310x2	2.0
5	WA0305+WA0310x2	2.5

※ Adjusting washer adjusts the drilling diameter within 5 mm

King Drill

For large diameter drilling

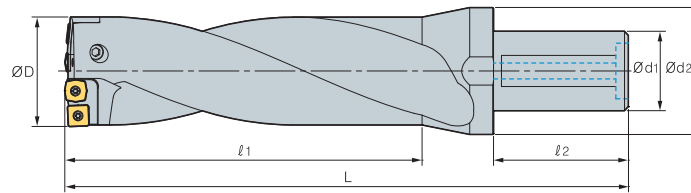

(mm)

Designation	ØD	Ød ₁	Ød ₂	l ₁	l ₂	L	Cartridge		Screw	Wrench	
							Internal	External			
K2D	616550-11	61~65	50	80	130	80	255	KDC6165C	KDC6165P	FTKA03508	TW15S
	657050-13	65~70	50	88	140	80	265	KDC6570C	KDC6570P	FTKA0410	TW15S
	707550-13	70~75	50	88	150	80	275	KDC7075C	KDC7075P	FTKA0410	TW15S
	758050-13	75~80	50	88	160	80	285	KDC7580C	KDC7580P	FTKA0410	TW15S
	808550-15	80~85	50	88	170	80	295	KDC8085C	KDC8085P	FTNC04511	TW20S
	859050-15	85~90	50	95	180	80	305	KDC8590C	KDC8590P	FTNC04511	TW20S
	909550-15	90~95	50	95	190	80	315	KDC9095C	KDC9095P	FTNC04511	TW20S
	9510050-18	95~100	50	95	200	80	325	KDC95100C	KDC95100P	FTNA0511	TW20-100
K3D	616550-11	61~65	50	80	195	80	320	KDC6165C	KDC6165P	FTKA03508	TW15S
	657050-13	65~70	50	88	210	80	335	KDC6570C	KDC6570P	FTKA0410	TW15S
	707550-13	70~75	50	88	225	80	350	KDC7075C	KDC7075P	FTKA0410	TW15S
	758050-13	75~80	50	88	240	80	365	KDC7580C	KDC7580P	FTKA0410	TW15S
	808550-15	80~85	50	88	255	80	380	KDC8085C	KDC8085P	FTNC04511	TW20S
	859050-15	85~90	50	95	270	80	395	KDC8590C	KDC8590P	FTNC04511	TW20S
	909550-15	90~95	50	95	285	80	410	KDC9095C	KDC9095P	FTNC04511	TW20S
	9510050-18	95~100	50	95	300	80	425	KDC95100C	KDC95100P	FTNA0511	TW20-100
K4D	616550-11	61~65	50	80	260	80	385	KDC6165C	KDC6165P	FTKA03508	TW15S
	657050-13	65~70	50	88	280	80	405	KDC6570C	KDC6570P	FTKA0410	TW15S
	707550-13	70~75	50	88	300	80	425	KDC7075C	KDC7075P	FTKA0410	TW15S
	758050-13	75~80	50	88	320	80	445	KDC7580C	KDC7580P	FTKA0410	TW15S
	808550-15	80~85	50	88	340	80	465	KDC8085C	KDC8085P	FTNC04511	TW20S
	859050-15	85~90	50	95	360	80	485	KDC8590C	KDC8590P	FTNC04511	TW20S
	909550-15	90~95	50	95	380	80	505	KDC9095C	KDC9095P	FTNC04511	TW20S
	9510050-18	95~100	50	95	400	80	525	KDC95100C	KDC95100P	FTNA0511	TW20-100

↻ Applicable inserts G04~05

↻ Parts

Cartridge		Range (Ø)	Insert				Screw	Wrench
Internal	External		Designation	Quantity	Designation	Quantity		
KDC6165C	KDC6165P	61 ~ 65	XO□T11T306-□□	2	SP□T11T308-□□	2	FTKA03508	TW15S
KDC6570C	KDC6570P	65 ~ 70	XO□T130406-□□	2	SP□T130410-□□	2	FTKA0410	TW15S
KDC7075C	KDC7075P	70 ~ 75	XO□T130406-□□	2	SP□T130410-□□	2	FTKA0410	TW15S
KDC7580C	KDC7580P	75 ~ 80	XO□T130406-□□	2	SP□T130410-□□	2	FTKA0410	TW15S
KDC8085C	KDC8085P	80 ~ 85	XO□T15M508-□□	2	SP□T15M510-□□	2	FTNC04511	TW20S
KDC8590C	KDC8590P	85 ~ 90	XO□T15M508-□□	2	SP□T15M510-□□	2	FTNC04511	TW20S
KDC9095C	KDC9095P	90 ~ 95	XO□T15M508-□□	2	SP□T15M510-□□	2	FTNC04511	TW20S
KDC95100C	KDC95100P	95 ~ 100	XO□T180508-□□	2	SP□T180510-□□	2	FTNA0511	TW20-100



Cone shaped head indexable drill

TPDC **new**

- Clamping design
 - One step clamp system → Increased stability
 - Clamping system allowing to change inserts while the holder is attached on the machine → Shortened setting time
- Optimized blade design
 - Excellent chip control → Wide application range in various types of materials.
- Helical shaped coolant hole system
 - Wide chip pocket area secured → Better lubrication + chip flow improved
- Material technology
 - Ultra-fine substrate + Multi-layer coating applied → Excellent anti chipping & wear resistance

➤ Code system of holder

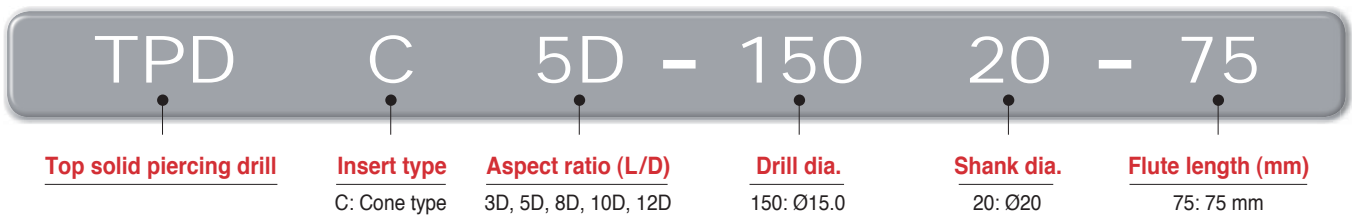

➤ Code system of insert



➤ Features

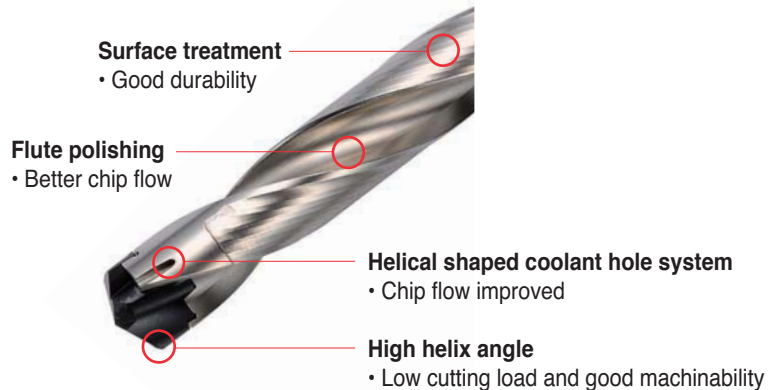
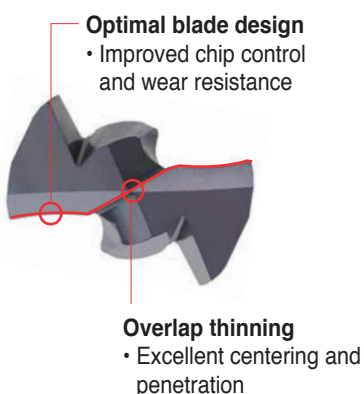

Features of clamping system

- One Step Clamp System → Easy and quick tool change with good repeatability
 - Clamping area: Easy and fast tool change
 - Anti-rotating area: Performs as a stopper
 - Clamping and anti-rotating area make an acute angle to prevent insert rotation while machining

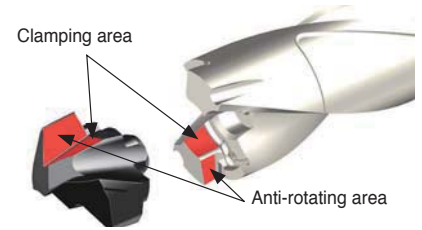

Performance evaluation

Durability test

- **Workpiece** SCM440 (HRC22)
 - Drill dia. (mm) = \varnothing 15.0
 - vc (m/min) = 90, fn (mm/rev) = 0.25
 - ap (mm) = 60, wet
- **Tools**
 - Inserts** TPD1500CP (PC5335)
 - Holder** TPDC5D-15020-75

After using 40 inserts, the setting run-out remains below $15\mu\text{m}$

Sustainability test

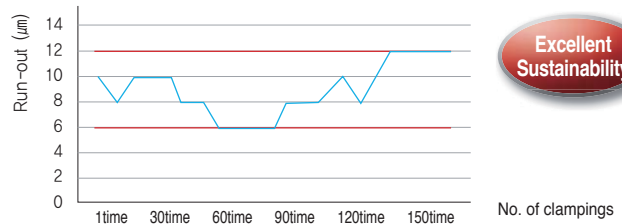

After clamping 150 times, the drill run-out remains

Application examples

- **Use** Part of machine
- **Workpiece** Alloy steel (SCM440, HRC22)
- **Cutting conditions**
 - Drill dia. (mm) = \varnothing 19.0
 - vc (m/min) = 100
 - fn (mm/rev) = 0.3
 - ap (mm) = 90, wet
- **Tools**
 - Inserts** TPD1900CP (PC5335)
 - Holder** TPDC5D-19025-95

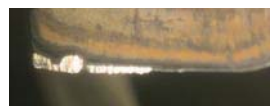

Test result

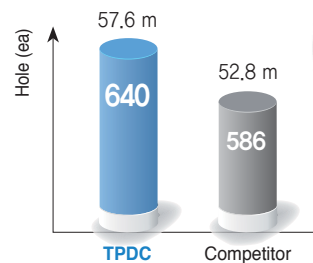

Lubricative multi-layer coating prevents chipping on cutting edges

- **Use** Part of machine
- **Workpiece** Carbon steel (SM45C, HRC40)
- **Cutting conditions**
 - Drill dia. (mm) = \varnothing 18.0
 - vc (m/min) = 60
 - fn (mm/rev) = 0.15
 - ap (mm) = 65, wet
- **Tools**
 - Inserts** TPD1800CP (PC5335)
 - Holder** TPDC5D-18025-90



Test result

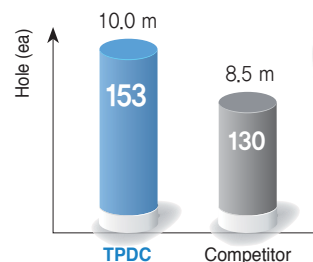

Lubricative multi-layer coating enhances wear resistance

Recommended cutting condition

Workpiece			Grade	vc (m/min)	Aspect ratio (L/D) = 3D, 5D			
ISO	Workpiece	HB			Feed rate (mm/rev) per drill dia. (mm)			
					Ø12.00~Ø15.99	Ø16.00~Ø25.99	Ø25.00~Ø30.99	
P	Carbon steel	Low carbon steel	80~120	PC5335 PC330P	110(80~140)	0.15~0.30	0.20~0.35	0.25~0.40
		High carbon steel	180~280	PC5335 PC330P	100(70~130)	0.15~0.30	0.20~0.35	0.25~0.40
	Alloy steel	Low alloy steel	140~260	PC5335 PC5300	110(80~140)	0.18~0.35	0.23~0.38	0.28~0.43
		Hardened low alloy steel	200~400	PC5335 PC5300	75(50~100)	0.18~0.35	0.23~0.38	0.28~0.43
		High alloy steel	260~320	PC5335	70(50~90)	0.18~0.30	0.20~0.35	0.25~0.40
		Hardened high alloy steel	300~450	PC5335 PC5300	60(40~80)	0.18~0.30	0.20~0.35	0.25~0.40
M	Stainless steel	Austenite series	135~275	PC330N	60(40~80)	0.05~0.15	0.10~0.20	0.15~0.25
		Ferrite series	135~275	PC330N	70(50~90)	0.10~0.20	0.15~0.30	0.20~0.35
		Martensite series	135~275	PC330N	70(50~90)	0.10~0.20	0.15~0.30	0.20~0.35
N	Non-ferrous metal	Aluminum alloy	30~150	H01	200(90~220)	0.35~0.45	0.40~0.50	0.45~0.55
		Copper alloy	150~160	H01	200(90~220)	0.35~0.45	0.40~0.50	0.45~0.55

- In case of 8D, reduce the cutting condition 40~50% lower than above after machining the beginning of hole(1.5D)
- In case of interrupted machining, reduce the feed to 0.1~0.15 around the interrupted part
- In case of 10D ~12D, follow the recommended cutting conditions below.
- In case of stainless steel machining, machine under low feed first then, set the best cutting condition checking machinability gradually

Coolant tip

- **Workpiece** SCM440 (HRC22)
- **Cutting conditions** vc (m/min) = 100, wet

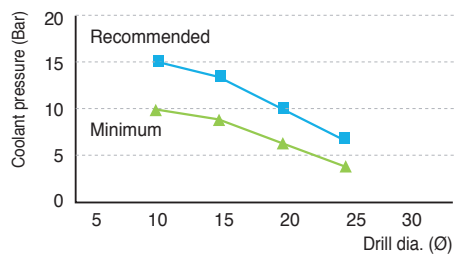
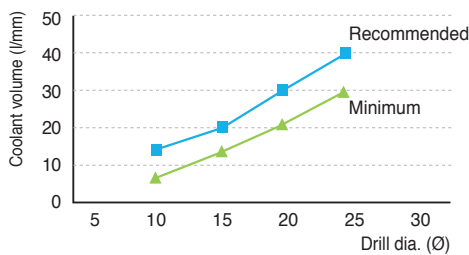

How to make good insert clamping



① Clean the mounting seat with air or cloth

② Put an insert on the holder

③ A part of wrench and B part of insert must be parallel to each other before clamp the insert
Turn the wrench clockwise to finish clamping

Clamped state

Precautions when setting

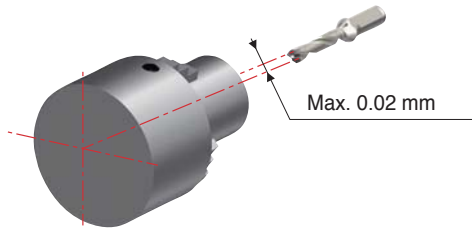

Setting of the horizontal equipment

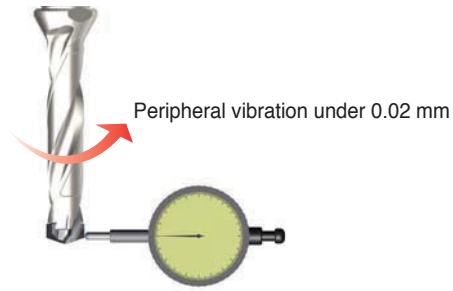

Setting of the vertical equipment

Precautions when drilling

Ramping	Overlapped	Plunging	Boring
<ol style="list-style-type: none"> A slope inclined more than 6° is not allowed When entering, reduce the feed to 30~50% 	<ol style="list-style-type: none"> Space between panels affects chip evacuation problem Do not make space between panels 	Not allowed	Not allowed

Recommended cutting conditions in deep hole (10D, 12D) drilling

• Drill with a pilot drill (recommended)

1. Drill a beginning hole (with a pilot drill)	2. Start drilling
Drill a beginning hole to the depth of 0.5D and 70% less cutting speed using a 1.5D or a 3D drill.	After replacing the drill to a new one, start drilling under the recommended cutting conditions.

• Drilling without a pilot drill

1. Drill a beginning hole (without a pilot drill)	2. Stop drilling	3. Ready for drilling	4. Start drilling
After drilling to the depth of 0.5D with 70% less cutting speed, stop drilling for 2~3 seconds without taking out the drill.	After taking out the drill without the injection of the coolant to the hole, stop machining for 2~3 seconds.	Insert the drill to the depth of 2~3 mm higher than the surface of the bottom of the hole and be ready to machine during 2~3 seconds after starting the injection of the coolant.	Start drilling under the recommended cutting conditions



TPDC Insert new

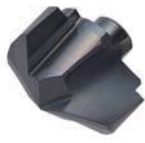

CP

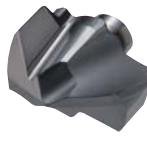

CM

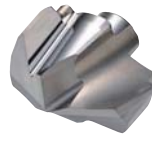

CN

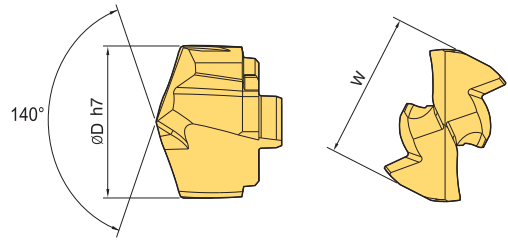

(mm)

Designation	Drill dia. (ØD)	Coated			Uncoated H01	Holder	Wrench
		PC5335	PC330P	PC330N			
TPD 1200CP,CM,CN	12.0	●				TPDC□D-12016-□	TPDC-W12
1220CP,CM,CN	12.2	●				TPDC□D-12516-□	
1250CP,CM,CN	12.5	●				TPDC□D-13016-□	
1260CP,CM,CN	12.6	●				TPDC□D-13516-□	TPDC-W13
1300CP,CM,CN	13.0	●				TPDC□D-14016-□	
1350CP,CM,CN	13.5	●				TPDC□D-14516-□	TPDC-W14
1400CP,CM,CN	14.0	●				TPDC□D-15020-□	
1420CP,CM,CN	14.2	●				TPDC□D-16020-□	TPDC-W15
1430CP,CM,CN	14.3	●				TPDC□D-17020-□	
1450CP,CM,CN	14.5	●				TPDC□D-18025-□	TPDC-W16
1500CP,CM,CN	15.0	●				TPDC□D-19025-□	
1550CP,CM,CN	15.5	●				TPDC□D-20025-□	TPDC-W17
1600CP,CM,CN	16.0	●				TPDC□D-21025-□	
1630CP,CM,CN	16.3	●				TPDC□D-22025-□	TPDC-W18
1650CP,CM,CN	16.5	●				TPDC□D-23025-□	
1670CP,CM,CN	16.7	●				TPDC□D-24032-□	TPDC-W19
1700CP,CM,CN	17.0	●				TPDC□D-25032-□	
1750CP,CM,CN	17.5	●				TPDC□D-26032-□	TPDC-W20
1770CP,CM,CN	17.7	●				TPDC□D-27032-□	
1800CP,CM,CN	18.0	●				TPDC□D-28032-□	TPDC-W21
1810CP,CM,CN	18.1	●				TPDC□D-29032-□	
1850CP,CM,CN	18.5	●				TPDC□D-30032-□	TPDC-W22
1860CP,CM,CN	18.6	●					
1870CP,CM,CN	18.7	●					TPDC-W23
1900CP,CM,CN	19.0	●					
1920CP,CM,CN	19.2	●					TPDC-W24
1950CP,CM,CN	19.5	●					
1970CP,CM,CN	19.7	●					TPDC-W25
2000CP,CM,CN	20.0	●					
2050CP,CM,CN	20.5	●					TPDC-W26
2100CP,CM,CN	21.0	●					
2150CP,CM,CN	21.5	●					TPDC-W27
2200CP,CM,CN	22.0	●					
2250CP,CM,CN	22.5	●					TPDC-W28
2260CP,CM,CN	22.6	●					
2270CP,CM,CN	22.7	●					TPDC-W29
2300CP,CM,CN	23.0	●					
2350CP,CM,CN	23.5	●					TPDC-W30
2400CP,CM,CN	24.0	●					
2450CP,CM,CN	24.5	●					TPDC-W31
2500CP,CM,CN	25.0	●					
2530CP,CM,CN	25.3	●					TPDC-W32
2550CP,CM,CN	25.5	●					
2580CP,CM,CN	25.8	●					TPDC-W33
2590CP,CM,CN	25.9	●					
2600CP,CM,CN	26.0	●					TPDC-W34
2650CP,CM,CN	26.5	●					
2700CP,CM,CN	27.0	●					TPDC-W35
2750CP,CM,CN	27.5	●					
2800CP,CM,CN	28.0	●					TPDC-W36
2850CP,CM,CN	28.5	●					
2900CP,CM,CN	29.0	●					TPDC-W37
2950CP,CM,CN	29.5	●					
3000CP,CM,CN	30.0	●					TPDC-W38
3050CP,CM,CN	30.5	●					

* We can provide if you order diameter 12.0~30.9 except for the stock items above ● : Stock Item

Parts (Recommended torque per wrench)

(mm)

Designation	Drill dia. (ØD)	Torque (N·m)	Designation	Drill dia. (ØD)	Torque (N·m)	Designation	Drill dia. (ØD)	Torque (N·m)
TPDC-W12	12	2.5	TPDC-W18	18	2.5	TPDC-W24	24	3.5
TPDC-W13	13	2.5	TPDC-W19	19	2.5	TPDC-W25	25	3.5
TPDC-W14	14	2.5	TPDC-W20	20	3.5	TPDC-W26	26	4.5
TPDC-W15	15	2.5	TPDC-W21	21	3.5	TPDC-W27	27	4.5
TPDC-W16	16	2.5	TPDC-W22	22	3.5	TPDC-W28	28	4.5
TPDC-W17	17	2.5	TPDC-W23	23	3.5	TPDC-W29	29	4.5
						TPDC-W30	30	4.5



TPDC (3D/5D/8D/10D/12D) new

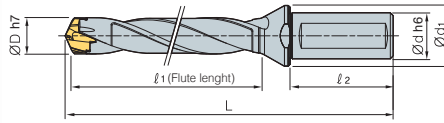

Fig.1

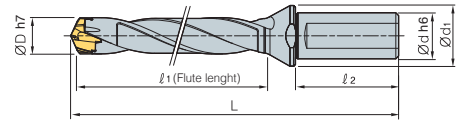

Fig.2

(mm)

Designation	ØD	Ød	Ød ₁	ℓ ₁	ℓ ₂	L	Insert	Fig.
TPDC 3D-12016-36	12.0~12.4	16	20	36	48	99	TPD1200C□-1249C□	1
3D-12516-38	12.5~12.9	16	20	38	48	101	TPD1250C□-1299C□	1
3D-13016-39	13.0~13.4	16	20	39	48	103	TPD1300C□-1349C□	1
3D-13516-41	13.5~13.9	16	20	41	48	105	TPD1350C□-1399C□	1
3D-14016-42	14.0~14.4	16	20	42	48	106	TPD1400C□-1449C□	1
3D-14516-44	14.5~14.9	16	20	44	48	107	TPD1450C□-1499C□	1
3D-15020-45	15.0~15.9	20	25	45	50	113	TPD1500C□-1599C□	2
3D-16020-48	16.0~16.9	20	25	48	50	117	TPD1600C□-1699C□	2
3D-17020-51	17.0~17.9	20	25	51	50	120	TPD1700C□-1799C□	2
3D-18025-54	18.0~18.9	25	33	54	56	132	TPD1800C□-1899C□	2
3D-19025-57	19.0~19.9	25	33	57	56	135	TPD1900C□-1999C□	2
3D-20025-60	20.0~20.9	25	33	60	56	138	TPD2000C□-2099C□	2
3D-21025-63	21.0~21.9	25	33	63	56	141	TPD2100C□-2199C□	2
3D-22025-66	22.0~22.9	25	33	66	56	145	TPD2200C□-2299C□	2
3D-23025-69	23.0~23.9	25	33	69	56	149	TPD2300C□-2399C□	2
3D-24032-72	24.0~24.9	32	43	72	60	159	TPD2400C□-2499C□	2
3D-25032-75	25.0~25.9	32	43	75	60	162	TPD2500C□-2599C□	2
3D-26032-78	26.0~26.9	32	43	78	60	173	TPD2600C□-2699C□	2
3D-27032-81	27.0~27.9	32	43	81	60	176	TPD2700C□-2799C□	2
3D-28032-84	28.0~28.9	32	43	84	60	180	TPD2800C□-2899C□	2
3D-29032-87	29.0~29.9	32	43	87	60	185	TPD2900C□-2999C□	2
3D-30032-90	30.0~30.9	32	43	90	60	188	TPD3000C□-3099C□	2
5D-12016-60	12.0~12.9	16	20	60	48	123	TPD1200C□-1249C□	1
5D-12516-63	12.5~12.9	16	20	63	48	126	TPD1250C□-1299C□	1
5D-13016-65	13.0~13.9	16	20	65	48	129	TPD1300C□-1349C□	1
5D-13516-68	13.5~13.9	16	20	68	48	132	TPD1350C□-1399C□	1
5D-14016-70	14.0~14.9	16	20	70	48	134	TPD1400C□-1449C□	1
5D-14516-73	14.5~14.9	16	20	73	48	136	TPD1450C□-1499C□	1
5D-15020-75	15.0~15.9	20	25	75	50	143	TPD1500C□-1599C□	2
5D-16020-80	16.0~16.9	20	25	80	50	149	TPD1600C□-1699C□	2
5D-17020-85	17.0~17.9	20	25	85	50	154	TPD1700C□-1799C□	2
5D-18025-90	18.0~18.9	25	33	90	56	168	TPD1800C□-1899C□	2
5D-19025-95	19.0~19.9	25	33	95	56	173	TPD1900C□-1999C□	2
5D-20025-100	20.0~20.9	25	33	100	56	178	TPD2000C□-2099C□	2
5D-21025-105	21.0~21.9	25	33	105	56	183	TPD2100C□-2199C□	2
5D-22025-110	22.0~22.9	25	33	110	56	189	TPD2200C□-2299C□	2
5D-23025-115	23.0~23.9	25	33	115	56	195	TPD2300C□-2399C□	2
5D-24032-120	24.0~24.9	32	43	120	60	207	TPD2400C□-2499C□	2
5D-25032-125	25.0~25.9	32	43	125	60	212	TPD2500C□-2599C□	2
5D-26032-130	26.0~26.9	32	43	130	60	225	TPD2600C□-2699C□	2
5D-27032-135	27.0~27.9	32	43	135	60	230	TPD2700C□-2799C□	2
5D-28032-140	28.0~28.9	32	43	140	60	236	TPD2800C□-2899C□	2
5D-29032-145	29.0~29.9	32	43	145	60	243	TPD2900C□-2999C□	2
5D-30032-150	30.0~30.9	32	43	150	60	248	TPD3000C□-3099C□	2
8D-12016-96	12.0~12.9	16	20	96	48	159	TPD1200C□-1249C□	1
8D-12516-100	12.5~12.9	16	20	100	48	163	TPD1250C□-1299C□	1
8D-13016-104	13.0~13.9	16	20	104	48	168	TPD1300C□-1349C□	1
8D-13516-108	13.5~13.9	16	20	108	48	173	TPD1350C□-1399C□	1
8D-14016-112	14.0~14.9	16	20	112	48	176	TPD1400C□-1449C□	1
8D-14516-116	14.5~14.9	16	20	116	48	180	TPD1450C□-1499C□	1
8D-15020-120	15.0~15.9	20	25	120	50	188	TPD1500C□-1599C□	2
8D-16020-128	16.0~16.9	20	25	128	50	197	TPD1600C□-1699C□	2
8D-17020-136	17.0~17.9	20	25	136	50	205	TPD1700C□-1799C□	2
8D-18025-144	18.0~18.9	25	33	144	56	222	TPD1800C□-1899C□	2
8D-19025-152	19.0~19.9	25	33	152	56	230	TPD1900C□-1999C□	2

↻ Applicable inserts G31

※ The shank is based on DIN6535 and ISO9677



TPDC (3D/5D/8D/10D/12D) new

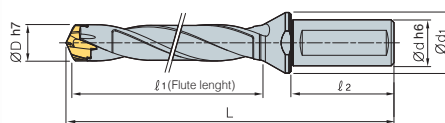

Fig.1

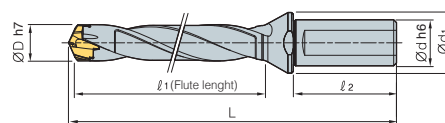

Fig.2

Designation		ØD	Ød	Ød ₁	l ₁	l ₂	L	Insert	Fig.
TPDC	8D-20025-160	20.0~20.9	25	33	160	56	238	TPD2000C□-2099C□	2
	8D-21025-168	21.0~21.9	25	33	168	56	246	TPD2100C□-2199C□	2
	8D-22025-176	22.0~22.9	25	33	176	56	255	TPD2200C□-2299C□	2
	8D-23025-184	23.0~23.9	25	33	184	56	264	TPD2300C□-2399C□	2
	8D-24032-192	24.0~24.9	32	43	192	60	279	TPD2400C□-2499C□	2
	8D-25032-200	25.0~25.9	32	43	200	60	287	TPD2500C□-2599C□	2
	8D-26032-208	26.0~26.9	32	43	208	60	303	TPD2600C□-2699C□	2
	8D-27032-216	27.0~27.9	32	43	216	60	311	TPD2700C□-2799C□	2
	8D-28032-224	28.0~28.9	32	43	224	60	320	TPD2800C□-2899C□	2
	8D-29032-232	29.0~29.9	32	43	232	60	330	TPD2900C□-2999C□	2
	8D-30032-240	30.0~30.9	32	43	240	60	338	TPD3000C□-3099C□	2
	10D-12016-120	12.0~12.4	16	20	120	48	183	TPD1200C□-1249C□	1
	10D-12516-125	12.5~12.9	16	20	125	48	188	TPD1250C□-1299C□	1
	10D-13016-130	13.0~13.4	16	20	130	48	194	TPD1300C□-1349C□	1
	10D-13516-135	13.5~13.9	16	20	135	48	199	TPD1350C□-1399C□	1
	10D-14016-140	14.0~14.4	16	20	140	48	204	TPD1400C□-1449C□	1
	10D-14516-145	14.5~14.9	16	20	145	48	208	TPD1450C□-1499C□	1
	10D-15020-150	15.0~15.9	20	25	150	50	218	TPD1500C□-1599C□	1
	10D-16020-160	16.0~16.9	20	25	160	50	229	TPD1600C□-1699C□	1
	10D-17020-170	17.0~17.9	20	25	170	50	239	TPD1700C□-1799C□	1
	10D-18025-180	18.0~18.9	25	33	180	56	258	TPD1800C□-1899C□	1
	10D-19025-190	19.0~19.9	25	33	190	56	268	TPD1900C□-1999C□	1
	10D-20025-200	20.0~20.9	25	33	200	56	278	TPD2000C□-2099C□	1
	10D-21025-210	21.0~21.9	25	33	210	56	288	TPD2100C□-2199C□	1
	10D-22025-220	22.0~22.9	25	33	220	56	299	TPD2200C□-2299C□	1
	10D-23025-230	23.0~23.9	25	33	230	56	310	TPD2300C□-2399C□	1
	10D-24032-240	24.0~24.9	32	43	240	60	327	TPD2400C□-2499C□	2
	10D-25032-250	25.0~25.9	32	43	250	60	337	TPD2500C□-2599C□	2
	10D-26032-260	26.0~26.9	32	43	260	60	355	TPD2600C□-2699C□	2
	10D-27032-270	27.0~27.9	32	43	270	60	365	TPD2700C□-2799C□	2
	10D-28032-280	28.0~28.9	32	43	280	60	376	TPD2800C□-2899C□	2
	10D-29032-290	29.0~29.9	32	43	290	60	388	TPD2900C□-2999C□	2
	10D-30032-300	30.0~30.9	32	43	300	60	398	TPD3000C□-3099C□	2
12D-12016-144	12.0~12.4	16	20	144	48	207	TPD1200C□-1249C□	1	
12D-12516-150	12.5~12.9	16	20	150	48	213	TPD1250C□-1299C□	1	
12D-13016-156	13.0~13.4	16	20	156	48	220	TPD1300C□-1349C□	1	
12D-13516-162	13.5~13.9	16	20	162	48	226	TPD1350C□-1399C□	1	
12D-14016-168	14.0~14.4	16	20	168	48	232	TPD1400C□-1449C□	1	
12D-14516-174	14.5~14.9	16	20	174	48	237	TPD1450C□-1499C□	1	
12D-15020-180	15.0~15.9	20	25	180	50	248	TPD1500C□-1599C□	1	
12D-16020-192	16.0~16.9	20	25	192	50	261	TPD1600C□-1699C□	1	
12D-17020-204	17.0~17.9	20	25	204	50	273	TPD1700C□-1799C□	1	
12D-18025-216	18.0~18.9	25	33	216	56	294	TPD1800C□-1899C□	1	
12D-19025-228	19.0~19.9	25	33	228	56	306	TPD1900C□-1999C□	1	
12D-20025-240	20.0~20.9	25	33	240	56	318	TPD2000C□-2099C□	1	
12D-21025-252	21.0~21.9	25	33	252	56	330	TPD2100C□-2199C□	1	
12D-22025-264	22.0~22.9	25	33	264	56	343	TPD2200C□-2299C□	1	
12D-23025-276	23.0~23.9	25	33	276	56	356	TPD2300C□-2399C□	1	
12D-24032-288	24.0~24.9	32	43	288	60	375	TPD2400C□-2499C□	2	
12D-25032-300	25.0~25.9	32	43	300	60	387	TPD2500C□-2599C□	2	
12D-26032-312	26.0~26.9	32	43	312	60	407	TPD2600C□-2699C□	2	
12D-27032-324	27.0~27.9	32	43	324	60	419	TPD2700C□-2799C□	2	
12D-28032-336	28.0~28.9	32	43	336	60	432	TPD2800C□-2899C□	2	
12D-29032-348	29.0~29.9	32	43	348	60	446	TPD2900C□-2999C□	2	
12D-30032-360	30.0~30.9	32	43	360	60	458	TPD3000C□-3099C□	2	

↻ Applicable inserts G31

※ The shank is based on DIN6535 and ISO9677

G Technical Information for TPDB Plus

Highly precise and efficient top solid indexable drill

TPDB Plus **new**

- Highly precise clamping system - Superior clamping precision with auto-centering system and highly precise grinding clamping parts
- Screw on clamping system - Easy to replace inserts
- Sharp cutting edge - Low cutting load and good chip control
- Holder with excellent durability - Holder with high rigidity and excellent wear resistance due to special surface treatment
- Holder with excellent chip control - Low cutting resistance and outstanding chip evaluation applying high helix angle

Code system of holder



Code system of insert



Features

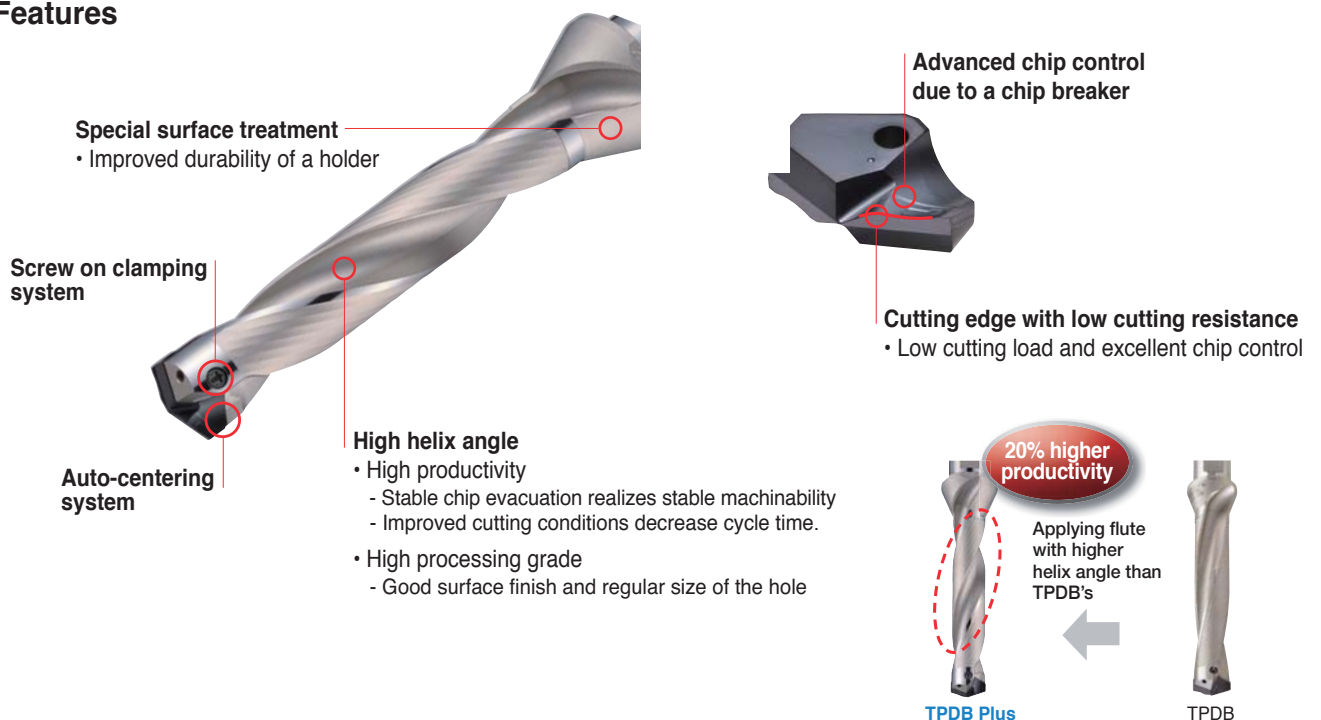

Application range

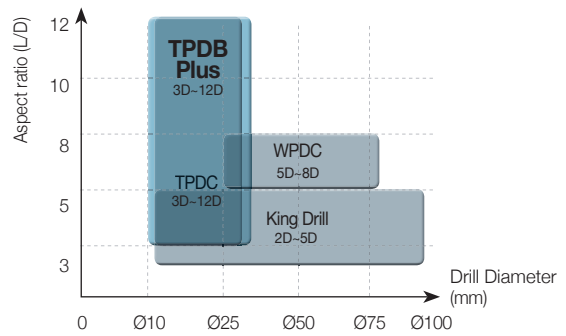
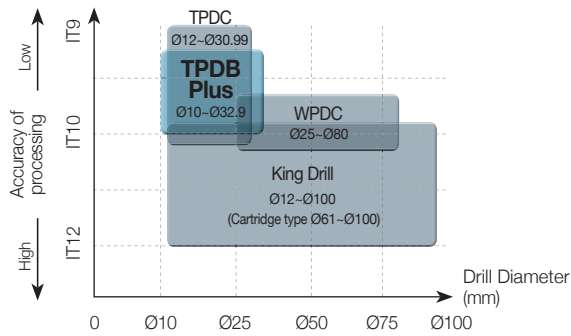

Tools	Application range					
	Drill Diameter (Ø)	Aspect ratio (L/D)	Tolerance of drill dia.	Tolerance	Surface finish of hole (Ra)	Workpiece
TPDB Plus	10-32.9 mm	3, 5, 8, 10, 12	h7	IT10	≤ 2.0µm	P, K

Performance evaluation

Run-out

- **Workpiece** Alloy steel (SCM440)
- **Cutting conditions** Drill dia.(mm) = Ø25, vc (m/min) = 90
fn (mm/rev) = 0.25, ap (mm) = 120, wet (20 bar)
- **Tools** TPDB250-32-5-P(PC5300)

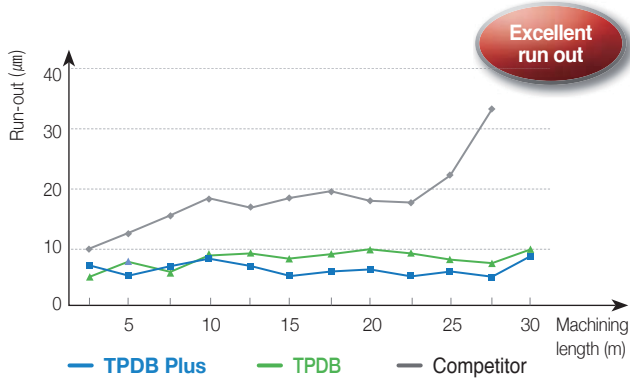

Cutting load

- **Workpiece** Alloy steel (SCM440)
- **Cutting conditions** Drill dia.(mm) = Ø25, vc (m/min) = 120
fn (mm/rev) = 0.25, ap (mm) = 120, wet (20 bar)
- **Tools** TPDB250-32-5-P (PC5300)

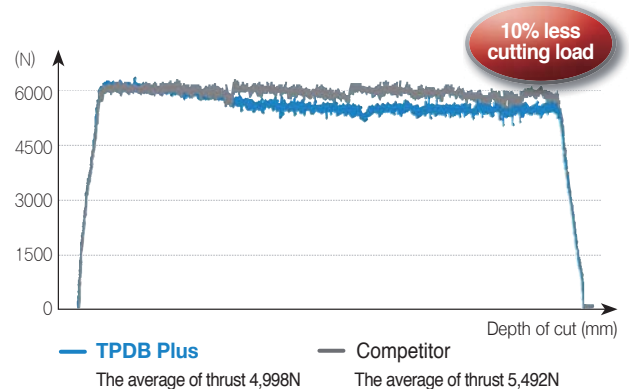

Outstanding roundness of hole

- **Workpiece** Alloy steel (SCM440)
- **Cutting conditions** Drill dia.(mm) = Ø25, vc (m/min) = 90/120, fn (mm/rev) = 0.25/0.35, ap (mm) = 120, wet (20 bar)
- **Tools** TPDB250-32-5-P (PC5300)

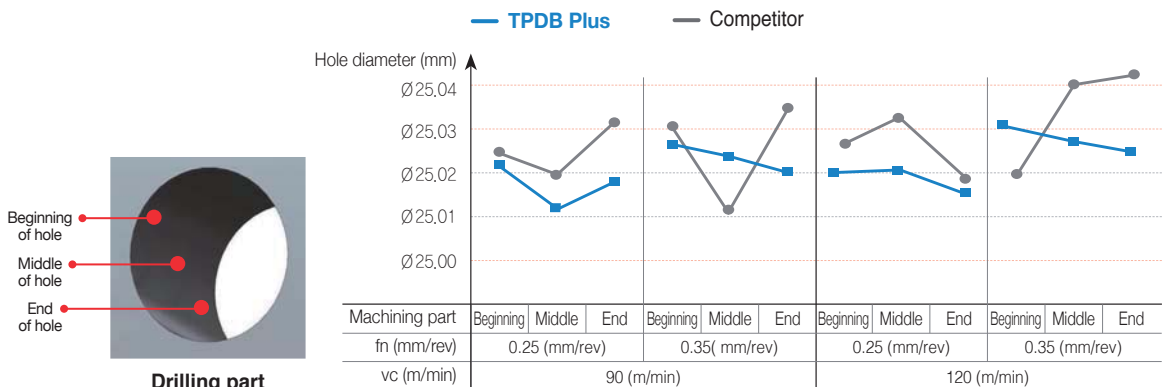

Recommended Cutting Conditions





Workpiece			Grade	vc (m/min)	Aspect ratio (L/D) = 3D, 5D			
ISO	Workpiece	HB			Feed rate (mm/rev) per drill dia. (mm)			
					Ø10~Ø16.9	Ø17~Ø26.9	Ø27~Ø32.9	
P	Carbon steel	Low carbon steel	80~120	PC5335 PC330P	110(80~140)	0.15~0.30	0.20~0.35	0.25~0.40
		High carbon steel	180~280	PC5335 PC330P	100(70~130)	0.15~0.30	0.20~0.35	0.25~0.40
	Alloy steel	Low alloy steel	140~260	PC5300	110(80~140)	0.18~0.35	0.23~0.38	0.28~0.43
		Low alloy heat treated steel	200~400	PC5300	75(50~100)	0.18~0.35	0.23~0.38	0.28~0.43
		High alloy steel	50~260	PC5300	70(50~90)	0.18~0.30	0.20~0.35	0.25~0.40
		High alloy heat treated steel	220~450	PC5300	60(40~80)	0.18~0.30	0.20~0.35	0.25~0.40
K	Cast iron	Gray cast iron	150~230	PC5300	110(80~140)	0.18~0.35	0.20~0.40	0.25~0.45
		Ductile cast iron	160~260	PC5300	100(70~130)	0.18~0.35	0.20~0.40	0.25~0.45

※ In case of 8D, machine in 20-30% lower cutting conditions than the mentioned above, or machine the beginning of hole (1.5D) before drilling.

※ In interrupted machining, reduce the feed to 0.1-0.15 machining around the interrupted part.

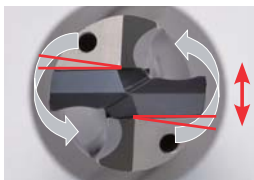
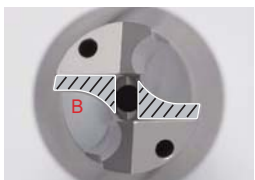
※ Prefer to the 'Recommended drilling method' on the page 37 for drilling of 10D -12D

Replacement of Holders and Screws

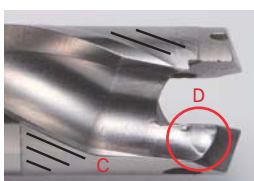
Worn part	How to check	Description
[Pic.1] 	[Pic.2] Check the gap 	<ul style="list-style-type: none"> In case of drilling for a long time as shown in the [Pic.1] the 'A' part is torn and twisted due to torque. As shown in the [Pic.2] check the gap between the insert and the tip seat turning the clamped insert from side to side. If there is a gap between them, replace the used holder to a new one.
[Pic.3] 	[Pic.4] Check the moving 	<ul style="list-style-type: none"> The insert could move up or down due to the load on the Z-axis in drilling over an extended period of time which causes wear on the 'B' part as shown the [Pic.3]. After clamping an insert, if the insert is moving or there is a gap between the insert and the tip seat as shown in the [Pic.4] replace the used holder to a new one.
[Pic.5] 	Check the moving 	<ul style="list-style-type: none"> After an extended period of use, the screw can be worn as shown in the 'E' part of [Pic.5] which could decrease the clamping force of the insert. When the screw is worn, replace the old screw to a new one among the enclosed extras. Spreading the grease on the screw makes it last longer.
[Pic.6] ① Check the 'C' and 'D' parts as shown in the [Pic.6] ② Check whether the chips are getting longer or not.		<ul style="list-style-type: none"> Winding or jamming of long and tiny chips in drilling causes wear or scratch on the 'C' part as shown in the [Pic.6] due to chattering from machining in improper cutting conditions. In that case, reset the cutting conditions and check the Run-out before machining. The excessive wear of the part 'D' as shown in the [Pic.6] relating to chip curling might cause long chips.



How to Clamp a TPDB Plus Insert

Clamping an insert to a holder



- ❶ Put an insert on the tip seat of the holder.
- ❷ As the [Pic.1], push the insert to the v-shaped groove of the holder.
- ❸ Screw and clamp the insert.

Changing the used insert to a new one



- ❶ Unscrew and separate the used insert from the holder.
- ❷ As the [Pic.2], clean the insert seat.
- ❸ Put a new insert on the tip seat.
- ❹ As the [Pic.3], clamp the insert pushing it with a hand not to separate from the holder.

Precaution in Drilling

Drilling of angled entrance



1. The approach angle between drill and the workpiece at the beginning should be less than 6°.
2. Reduce the feed to 30-50% than general cutting conditions at the beginning and the end of angled surface.

Drilling of stacked plates

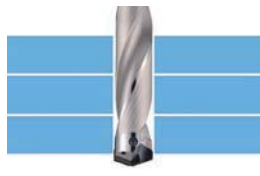

1. Gap between the plates could make wrong chip evacuation causing fracture of the drill.
2. Place the workpiece, stacked plates without any gap between each.

Plunging



1. Irregular cutting resistance in plunging could cause fracture and deformation of the drill.

Boring



1. Boring is not recommended due to wear and chipping in the corner of the insert.

Check Point in Drilling

- Condition of the clamped workpiece
- Revolution of the main axis of the machine
- Condition of the holder
- Run-out of the clamped drill (Max. 0.03 mm)
- Condition of supplying coolant (pressure, floconcentration)
- Chip evacuation

Supply of Coolant

- Supply enough coolant to the beginning of the hole.
- Minimum pressure of oil coolant: 5 bar
- Minimum flow of coolant: 5 l/min

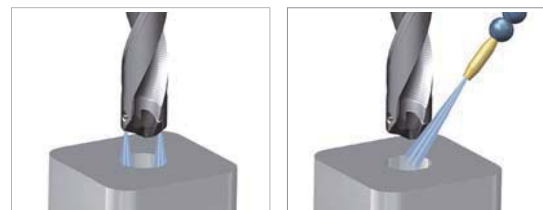

Recommended Drilling Method (10D, 12D)

Machine a beginning hole (with a pilot drill)

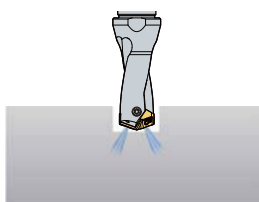

- Machine a beginning hole with the depth of cut as 0.5D and at 30% lower speed using a 1.5D or 3D drill.

Start drilling

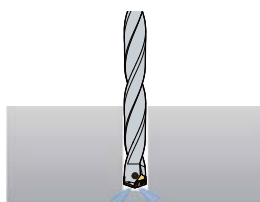

- After machining the beginning hole, replace the pilot drill to a drill for drilling and machine in recommended cutting conditions.

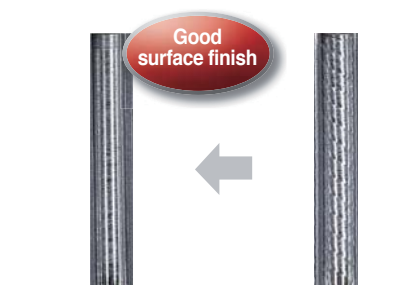

Result of recommended drilling

Result of general drilling

TPDB Plus Insert new

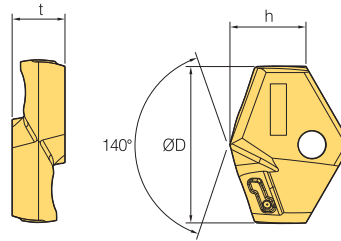

Designation	Coated			ØD	h	t
	PC5300	PC5335	PC330P			
TPD 100B~109B	●			10.0 ~ 10.9	5.5	3.5
110B~119B	●	●		11.0 ~ 11.9	5.8	3.5
120B~129B	●	●		12.0 ~ 12.9	6.3	3.5
130B~139B	●			13.0 ~ 13.9	6.5	4.0
140B~149B	●	●		14.0 ~ 14.9	6.8	4.0
150B~159B	●	●		15.0 ~ 15.9	7.0	4.0
160B~169B	●	●		16.0 ~ 16.9	7.7	5.5
170B~179B	●	●		17.0 ~ 17.9	7.9	5.5
180B~189B	●	●		18.0 ~ 18.9	8.1	6.0
190B~199B	●	●		19.0 ~ 19.9	8.3	6.0
200B~209B	●	●		20.0 ~ 20.9	9.7	6.5
210B~219B	●	●		21.0 ~ 21.9	9.4	6.5
220B~229B	●	●		22.0 ~ 22.9	9.6	7.0
230B~239B	●	●		23.0 ~ 23.9	9.8	7.0
240B~249B	●	●		24.0 ~ 24.9	10.7	7.5
250B~259B	●	●		25.0 ~ 25.9	10.9	7.5
260B~269B	●	●		26.0 ~ 26.9	11.0	8.5
270B~279B	●			27.0 ~ 27.9	11.8	8.5
280B~289B	●			28.0 ~ 28.9	12.6	9.5
290B~299B	●			29.0 ~ 29.9	12.9	9.5
300B~309B	●			30.0 ~ 30.9	13.0	10.0
310B~319B	●			31.0 ~ 31.9	13.2	10.0
320B~329B	●			32.0 ~ 32.9	13.4	10.0

● : Stock Item

Parts

Designation	Drill dia. (ØD)	Screw	Wrench	Torque (N·m)
TPD 100B~129B	10.0 ~ 12.9	FTNB0209-P	TW06P	0.4
130B~149B	13.0 ~ 14.9	FTNB02512-P	TW07S	0.8
150B~179B	15.0 ~ 17.9	FTNB02514-P	TW07S	0.8
180B~199B	18.0 ~ 19.9	FTNB0316-P	TW09S	1.2
200B~239B	20.0 ~ 23.9	FTNB0319	TW09S	1.2
240B~259B	24.0 ~ 25.9	FTNB03522	TW15S	3.0
260B~279B	26.0 ~ 27.9	FTNB03524	TW15S	3.0
280B~299B	28.0 ~ 29.9	FTNB0426	TW15S	3.0
300B~329B	30.0 ~ 32.9	FTNB0528	TW20-100	4.0



TPDB Plus (3D) new

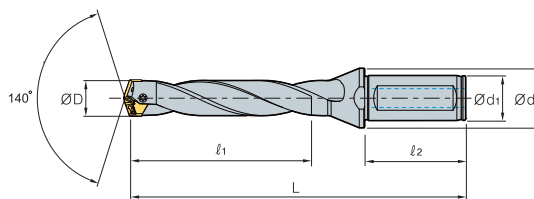

(mm)

Designation	ØD	Ød ₁	Ød ₂	ℓ ₁	ℓ ₂	L	Insert
TPDB 100-16-3-P	10.0 ~ 10.4	16	20	30.0	48	95	TPD100B ~ 104B
105-16-3-P	10.5 ~ 10.9	16	20	31.5	48	96	TPD105B ~ 109B
110-16-3-P	11.0 ~ 11.4	16	20	33.0	48	98	TPD110B ~ 114B
115-16-3-P	11.5 ~ 11.9	16	20	34.5	48	99	TPD115B ~ 119B
120-16-3-P	12.0 ~ 12.4	16	20	36.0	48	102	TPD120B ~ 124B
125-16-3-P	12.5 ~ 12.9	16	20	37.5	48	104	TPD125B ~ 129B
130-16-3-P	13.0 ~ 13.4	16	20	39.0	48	107	TPD130B ~ 134B
135-16-3-P	13.5 ~ 13.9	16	20	40.5	48	109	TPD135B ~ 139B
140-16-3-P	14.0 ~ 14.4	16	20	42.0	48	111	TPD140B ~ 144B
145-16-3-P	14.5 ~ 14.9	16	20	43.5	48	114	TPD145B ~ 149B
150-20-3-P	15.0 ~ 15.4	20	25	45.0	50	118	TPD150B ~ 154B
155-20-3-P	15.5 ~ 15.9	20	25	46.5	50	120	TPD155B ~ 159B
160-20-3-P	16.0 ~ 16.4	20	25	48.0	50	122	TPD160B ~ 164B
165-20-3-P	16.5 ~ 16.9	20	25	49.5	50	124	TPD165B ~ 169B
170-20-3-P	17.0 ~ 17.4	20	25	51.0	50	127	TPD170B ~ 174B
175-20-3-P	17.5 ~ 17.9	20	25	52.5	50	129	TPD175B ~ 179B
180-25-3-P	18.0 ~ 18.4	25	33	54.0	56	137	TPD180B ~ 184B
185-25-3-P	18.5 ~ 18.9	25	33	55.5	56	139	TPD185B ~ 189B
190-25-3-P	19.0 ~ 19.4	25	33	57.0	56	142	TPD190B ~ 194B
195-25-3-P	19.5 ~ 19.9	25	33	58.5	56	144	TPD195B ~ 199B
200-25-3-P	20.0 ~ 20.4	25	33	60.0	56	146	TPD200B ~ 204B
205-25-3-P	20.5 ~ 20.9	25	33	61.5	56	148	TPD205B ~ 209B
210-25-3-P	21.0 ~ 21.4	25	33	63.0	60	151	TPD210B ~ 214B
215-25-3-P	21.5 ~ 21.9	25	33	64.5	60	153	TPD215B ~ 219B
220-25-3-P	22.0 ~ 22.4	25	33	66.0	60	155	TPD220B ~ 224B
225-25-3-P	22.5 ~ 22.9	25	33	67.5	60	157	TPD225B ~ 229B
230-25-3-P	23.0 ~ 23.4	25	33	69.0	60	160	TPD230B ~ 234B
235-25-3-P	23.5 ~ 23.9	25	33	70.5	60	162	TPD235B ~ 239B
240-32-3-P	24.0 ~ 24.4	32	43	72.0	60	168	TPD240B ~ 244B
245-32-3-P	24.5 ~ 24.9	32	43	73.5	60	170	TPD245B ~ 249B
250-32-3-P	25.0 ~ 25.4	32	43	75.0	60	173	TPD250B ~ 254B
255-32-3-P	25.5 ~ 25.9	32	43	76.5	60	175	TPD255B ~ 259B
260-32-3-P	26.0 ~ 26.9	32	43	78.0	60	177	TPD260B ~ 269B
270-32-3-P	27.0 ~ 27.9	32	43	81.0	60	182	TPD270B ~ 279B
280-32-3-P	28.0 ~ 28.9	32	43	84.0	60	186	TPD280B ~ 289B
290-32-3-P	29.0 ~ 29.9	32	43	87.0	60	191	TPD290B ~ 299B
300-32-3-P	30.0 ~ 30.9	32	43	90.0	60	195	TPD300B ~ 309B
310-32-3-P	31.0 ~ 31.9	32	43	93.0	60	200	TPD310B ~ 319B
320-32-3-P	32.0 ~ 32.9	32	43	96.0	60	204	TPD320B ~ 329B

↻ Applicable inserts G38

TPDB Plus (5D) new

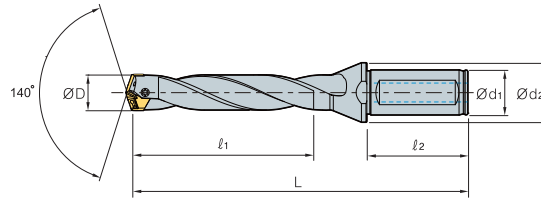

(mm)

Designation	ØD	Ød ₁	Ød ₂	ℓ ₁	ℓ ₂	L	Insert
TPDB 100-16-5-P	10.0 ~ 10.4	16	20	50.0	48	115	TPD100B ~ 104B
105-16-5-P	10.5 ~ 10.9	16	20	52.5	48	117	TPD105B ~ 109B
110-16-5-P	11.0 ~ 11.4	16	20	55.0	48	120	TPD110B ~ 114B
115-16-5-P	11.5 ~ 11.9	16	20	57.5	48	123	TPD115B ~ 119B
120-16-5-P	12.0 ~ 12.4	16	20	60.0	48	126	TPD120B ~ 124B
125-16-5-P	12.5 ~ 12.9	16	20	62.5	48	129	TPD125B ~ 129B
130-16-5-P	13.0 ~ 13.4	16	20	65.0	48	133	TPD130B ~ 134B
135-16-5-P	13.5 ~ 13.9	16	20	67.5	48	136	TPD135B ~ 139B
140-16-5-P	14.0 ~ 14.4	16	20	70.0	48	139	TPD140B ~ 144B
145-16-5-P	14.5 ~ 14.9	16	20	72.5	48	143	TPD145B ~ 149B
150-20-5-P	15.0 ~ 15.4	20	25	75.0	50	148	TPD150B ~ 154B
155-20-5-P	15.5 ~ 15.9	20	25	77.5	50	151	TPD155B ~ 159B
160-20-5-P	16.0 ~ 16.4	20	25	80.0	50	154	TPD160B ~ 164B
165-20-5-P	16.5 ~ 16.9	20	25	82.5	50	157	TPD165B ~ 169B
170-20-5-P	17.0 ~ 17.4	20	25	85.0	50	161	TPD170B ~ 174B
175-20-5-P	17.5 ~ 17.9	20	25	87.5	50	164	TPD175B ~ 179B
180-25-5-P	18.0 ~ 18.4	25	33	90.0	56	173	TPD180B ~ 184B
185-25-5-P	18.5 ~ 18.9	25	33	92.5	56	176	TPD185B ~ 189B
190-25-5-P	19.0 ~ 19.4	25	33	95.0	56	180	TPD190B ~ 194B
195-25-5-P	19.5 ~ 19.9	25	33	97.5	56	183	TPD195B ~ 199B
200-25-5-P	20.0 ~ 20.4	25	33	100.0	56	186	TPD200B ~ 204B
205-25-5-P	20.5 ~ 20.9	25	33	102.5	56	189	TPD205B ~ 209B
210-25-5-P	21.0 ~ 21.4	25	33	105.0	60	193	TPD210B ~ 214B
215-25-5-P	21.5 ~ 21.9	25	33	107.5	60	196	TPD215B ~ 219B
220-25-5-P	22.0 ~ 22.4	25	33	110.0	60	199	TPD220B ~ 224B
225-25-5-P	22.5 ~ 22.9	25	33	112.5	60	202	TPD225B ~ 229B
230-25-5-P	23.0 ~ 23.4	25	33	115.0	60	206	TPD230B ~ 234B
235-25-5-P	23.5 ~ 23.9	25	33	117.5	60	209	TPD235B ~ 239B
240-32-5-P	24.0 ~ 24.4	32	43	120.0	60	216	TPD240B ~ 244B
245-32-5-P	24.5 ~ 24.9	32	43	122.5	60	219	TPD245B ~ 249B
250-32-5-P	25.0 ~ 25.4	32	43	125.0	60	223	TPD250B ~ 254B
255-32-5-P	25.5 ~ 25.9	32	43	127.5	60	226	TPD255B ~ 259B
260-32-5-P	26.0 ~ 26.9	32	43	130.0	60	229	TPD260B ~ 269B
270-32-5-P	27.0 ~ 27.9	32	43	135.0	60	236	TPD270B ~ 279B
280-32-5-P	28.0 ~ 28.9	32	43	140.0	60	242	TPD280B ~ 289B
290-32-5-P	29.0 ~ 29.9	32	43	145.0	60	249	TPD290B ~ 299B
300-32-5-P	30.0 ~ 30.9	32	43	150.0	60	255	TPD300B ~ 309B
310-32-5-P	31.0 ~ 31.9	32	43	155.0	60	262	TPD310B ~ 319B
320-32-5-P	32.0 ~ 32.9	32	43	160.0	60	268	TPD320B ~ 329B

↻ Applicable inserts **G38**



TPDB Plus (8D) new

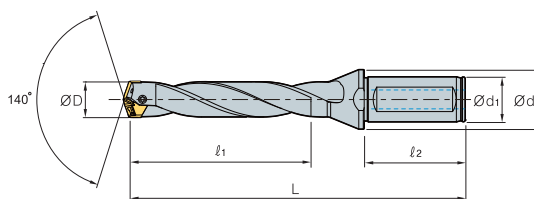

(mm)

Designation	ØD	Ød ₁	Ød ₂	l ₁	l ₂	L	Insert
TPDB 100-16-8-P	10.0 ~ 10.4	16	20	80	48	145	TPD100B ~ 104B
105-16-8-P	10.5 ~ 10.9	16	20	84	48	149	TPD105B ~ 109B
110-16-8-P	11.0 ~ 11.4	16	20	88	48	153	TPD110B ~ 114B
115-16-8-P	11.5 ~ 11.9	16	20	92	48	157	TPD115B ~ 119B
120-16-8-P	12.0 ~ 12.4	16	20	96	48	162	TPD120B ~ 124B
125-16-8-P	12.5 ~ 12.9	16	20	100	48	166.5	TPD125B ~ 129B
130-16-8-P	13.0 ~ 13.4	16	20	104	48	172	TPD130B ~ 134B
135-16-8-P	13.5 ~ 13.9	16	20	108	48	176.5	TPD135B ~ 139B
140-16-8-P	14.0 ~ 14.4	16	20	112	48	181	TPD140B ~ 144B
145-16-8-P	14.5 ~ 14.9	16	20	116	48	186.5	TPD145B ~ 149B
150-20-8-P	15.0 ~ 15.4	20	25	120	50	193	TPD150B ~ 154B
155-20-8-P	15.5 ~ 15.9	20	25	124	50	197.5	TPD155B ~ 159B
160-20-8-P	16.0 ~ 16.4	20	25	128	50	202	TPD160B ~ 164B
165-20-8-P	16.5 ~ 16.9	20	25	132	50	206.5	TPD165B ~ 169B
170-20-8-P	17.0 ~ 17.4	20	25	136	50	212	TPD170B ~ 174B
175-20-8-P	17.5 ~ 17.9	20	25	140	50	216.5	TPD175B ~ 179B
180-25-8-P	18.0 ~ 18.4	25	33	144	56	227	TPD180B ~ 184B
185-25-8-P	18.5 ~ 18.9	25	33	148	56	231.5	TPD185B ~ 189B
190-25-8-P	19.0 ~ 19.4	25	33	152	56	237	TPD190B ~ 194B
195-25-8-P	19.5 ~ 19.9	25	33	156	56	241.5	TPD195B ~ 199B
200-25-8-P	20.0 ~ 20.4	25	33	160	56	246	TPD200B ~ 204B
205-25-8-P	20.5 ~ 20.9	25	33	164	56	250.5	TPD205B ~ 209B
210-25-8-P	21.0 ~ 21.4	25	33	168	60	256	TPD210B ~ 214B
215-25-8-P	21.5 ~ 21.9	25	33	172	60	260.5	TPD215B ~ 219B
220-25-8-P	22.0 ~ 22.4	25	33	176	60	265	TPD220B ~ 224B
225-25-8-P	22.5 ~ 22.9	25	33	180	60	269.5	TPD225B ~ 229B
230-25-8-P	23.0 ~ 23.4	25	33	184	60	275	TPD230B ~ 234B
235-25-8-P	23.5 ~ 23.9	25	33	188	60	279.5	TPD235B ~ 239B
240-32-8-P	24.0 ~ 24.4	32	43	192	60	288	TPD240B ~ 244B
245-32-8-P	24.5 ~ 24.9	32	43	196	60	292.5	TPD245B ~ 249B
250-32-8-P	25.0 ~ 25.4	32	43	200	60	298	TPD250B ~ 254B
255-32-8-P	25.5 ~ 25.9	32	43	204	60	302.5	TPD255B ~ 259B
260-32-8-P	26.0 ~ 26.9	32	43	208	60	307	TPD260B ~ 269B
270-32-8-P	27.0 ~ 27.9	32	43	216	60	317	TPD270B ~ 279B
280-32-8-P	28.0 ~ 28.9	32	43	224	60	326	TPD280B ~ 289B
290-32-8-P	29.0 ~ 29.9	32	43	232	60	336	TPD290B ~ 299B
300-32-8-P	30.0 ~ 30.9	32	43	240	60	344	TPD300B ~ 309B
310-32-8-P	31.0 ~ 31.9	32	43	248	60	354	TPD310B ~ 319B
320-32-8-P	32.0 ~ 32.9	32	43	256	60	361	TPD320B ~ 329B

↻ Applicable inserts - G38

TPDB Plus (10D) new

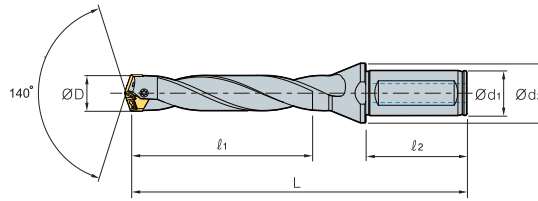

(mm)

Designation	ØD	Ød ₁	Ød ₂	ℓ ₁	ℓ ₂	L	Insert
TPDB 100-16-10-P	10.0 ~ 10.4	16	20	100	48	165	TPD100B ~ 104B
105-16-10-P	10.5 ~ 10.9	16	20	105	48	170	TPD105B ~ 109B
110-16-10-P	11.0 ~ 11.4	16	20	110	48	175	TPD110B ~ 114B
115-16-10-P	11.5 ~ 11.9	16	20	115	48	180	TPD115B ~ 119B
120-16-10-P	12.0 ~ 12.4	16	20	120	48	186	TPD120B ~ 124B
125-16-10-P	12.5 ~ 12.9	16	20	125	48	191.5	TPD125B ~ 129B
130-16-10-P	13.0 ~ 13.4	16	20	130	48	198	TPD130B ~ 134B
135-16-10-P	13.5 ~ 13.9	16	20	135	48	203.5	TPD135B ~ 139B
140-16-10-P	14.0 ~ 14.4	16	20	140	48	209	TPD140B ~ 144B
145-16-10-P	14.5 ~ 14.9	16	20	145	48	215.5	TPD145B ~ 149B
150-20-10-P	15.0 ~ 15.4	20	25	150	50	223	TPD150B ~ 154B
155-20-10-P	15.5 ~ 15.9	20	25	155	50	228.5	TPD155B ~ 159B
160-20-10-P	16.0 ~ 16.4	20	25	160	50	234	TPD160B ~ 164B
165-20-10-P	16.5 ~ 16.9	20	25	165	50	239.5	TPD165B ~ 169B
170-20-10-P	17.0 ~ 17.4	20	25	170	50	246	TPD170B ~ 174B
175-20-10-P	17.5 ~ 17.9	20	25	175	50	251.5	TPD175B ~ 179B
180-25-10-P	18.0 ~ 18.4	25	33	180	56	263	TPD180B ~ 184B
185-25-10-P	18.5 ~ 18.9	25	33	185	56	268.5	TPD185B ~ 189B
190-25-10-P	19.0 ~ 19.4	25	33	190	56	275	TPD190B ~ 194B
195-25-10-P	19.5 ~ 19.9	25	33	195	56	280.5	TPD195B ~ 199B
200-25-10-P	20.0 ~ 20.4	25	33	200	56	286	TPD200B ~ 204B
205-25-10-P	20.5 ~ 20.9	25	33	205	56	291.5	TPD205B ~ 209B
210-25-10-P	21.0 ~ 21.4	25	33	210	60	298	TPD210B ~ 214B
215-25-10-P	21.5 ~ 21.9	25	33	215	60	303.5	TPD215B ~ 219B
220-25-10-P	22.0 ~ 22.4	25	33	220	60	309	TPD220B ~ 224B
225-25-10-P	22.5 ~ 22.9	25	33	225	60	314.5	TPD225B ~ 229B
230-25-10-P	23.0 ~ 23.4	25	33	230	60	321	TPD230B ~ 234B
235-25-10-P	23.5 ~ 23.9	25	33	235	60	326.5	TPD235B ~ 239B
240-32-10-P	24.0 ~ 24.4	32	43	240	60	336	TPD240B ~ 244B
245-32-10-P	24.5 ~ 24.9	32	43	245	60	341.5	TPD245B ~ 249B
250-32-10-P	25.0 ~ 25.4	32	43	250	60	348	TPD250B ~ 254B
255-32-10-P	25.5 ~ 25.9	32	43	255	60	353.5	TPD255B ~ 259B
260-32-10-P	26.0 ~ 26.9	32	43	260	60	359	TPD260B ~ 269B
270-32-10-P	27.0 ~ 27.9	32	43	270	60	371	TPD270B ~ 279B
280-32-10-P	28.0 ~ 28.9	32	43	280	60	382	TPD280B ~ 289B
290-32-10-P	29.0 ~ 29.9	32	43	290	60	394	TPD290B ~ 299B
300-32-10-P	30.0 ~ 30.9	32	43	300	60	404	TPD300B ~ 309B
310-32-10-P	31.0 ~ 31.9	32	43	310	60	416	TPD310B ~ 319B
320-32-10-P	32.0 ~ 32.9	32	43	320	60	425	TPD320B ~ 329B

↻ Applicable inserts G38



TPDB Plus (12D) new

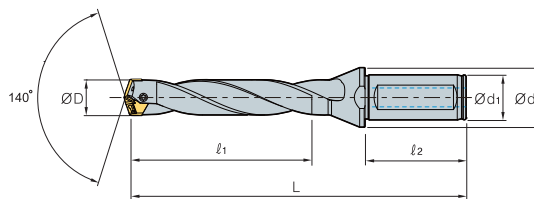

(mm)

Designation	ØD	Ød ₁	Ød ₂	ℓ ₁	ℓ ₂	L	Insert
TPDB 100-16-12-P	10.0 ~ 10.4	16	20	120	48	185	TPD100B ~ 104B
105-16-12-P	10.5 ~ 10.9	16	20	126	48	191	TPD105B ~ 109B
110-16-12-P	11.0 ~ 11.4	16	20	132	48	197	TPD110B ~ 114B
115-16-12-P	11.5 ~ 11.9	16	20	138	48	203	TPD115B ~ 119B
120-16-12-P	12.0 ~ 12.4	16	20	144	48	210	TPD120B ~ 124B
125-16-12-P	12.5 ~ 12.9	16	20	150	48	216.5	TPD125B ~ 129B
130-16-12-P	13.0 ~ 13.4	16	20	156	48	224	TPD130B ~ 134B
135-16-12-P	13.5 ~ 13.9	16	20	162	48	230.5	TPD135B ~ 139B
140-16-12-P	14.0 ~ 14.4	16	20	168	48	237	TPD140B ~ 144B
145-16-12-P	14.5 ~ 14.9	16	20	174	48	244.5	TPD145B ~ 149B
150-20-12-P	15.0 ~ 15.4	20	25	180	50	253	TPD150B ~ 154B
155-20-12-P	15.5 ~ 15.9	20	25	186	50	259.5	TPD155B ~ 159B
160-20-12-P	16.0 ~ 16.4	20	25	192	50	266	TPD160B ~ 164B
165-20-12-P	16.5 ~ 16.9	20	25	198	50	272.5	TPD165B ~ 169B
170-20-12-P	17.0 ~ 17.4	20	25	204	50	280	TPD170B ~ 174B
175-20-12-P	17.5 ~ 17.9	20	25	210	50	286.5	TPD175B ~ 179B
180-25-12-P	18.0 ~ 18.4	25	33	216	56	299	TPD180B ~ 184B
185-25-12-P	18.5 ~ 18.9	25	33	222	56	305.5	TPD185B ~ 189B
190-25-12-P	19.0 ~ 19.4	25	33	228	56	313	TPD190B ~ 194B
195-25-12-P	19.5 ~ 19.9	25	33	234	56	319.5	TPD195B ~ 199B
200-25-12-P	20.0 ~ 20.4	25	33	240	56	326	TPD200B ~ 204B
205-25-12-P	20.5 ~ 20.9	25	33	246	56	332.5	TPD205B ~ 209B
210-25-12-P	21.0 ~ 21.4	25	33	252	60	340	TPD210B ~ 214B
215-25-12-P	21.5 ~ 21.9	25	33	258	60	346.5	TPD215B ~ 219B
220-25-12-P	22.0 ~ 22.4	25	33	264	60	353	TPD220B ~ 224B
225-25-12-P	22.5 ~ 22.9	25	33	270	60	359.5	TPD225B ~ 229B
230-25-12-P	23.0 ~ 23.4	25	33	276	60	367	TPD230B ~ 234B
235-25-12-P	23.5 ~ 23.9	25	33	282	60	373.5	TPD235B ~ 239B
240-32-12-P	24.0 ~ 24.4	32	43	288	60	384	TPD240B ~ 244B
245-32-12-P	24.5 ~ 24.9	32	43	294	60	390.5	TPD245B ~ 249B
250-32-12-P	25.0 ~ 25.4	32	43	300	60	398	TPD250B ~ 254B
255-32-12-P	25.5 ~ 25.9	32	43	306	60	404.5	TPD255B ~ 259B
260-32-12-P	26.0 ~ 26.9	32	43	312	60	411	TPD260B ~ 269B
270-32-12-P	27.0 ~ 27.9	32	43	324	60	425	TPD270B ~ 279B
280-32-12-P	28.0 ~ 28.9	32	43	336	60	438	TPD280B ~ 289B
290-32-12-P	29.0 ~ 29.9	32	43	348	60	452	TPD290B ~ 299B
300-32-12-P	30.0 ~ 30.9	32	43	360	60	464	TPD300B ~ 309B
310-32-12-P	31.0 ~ 31.9	32	43	372	60	478	TPD310B ~ 319B
320-32-12-P	32.0 ~ 32.9	32	43	384	60	489	TPD320B ~ 329B

↻ Applicable inserts G38

G Technical Information for TPDB-H

The exclusive top solid indexable drill for steel-frame structure, H-Beam

TPDB-H new

- The highly efficient and exclusive top solid indexable drill for steel-frame structures such as H-Beam, steel sheet, etc
- High precision clamping system: High precision clamping due highly precise grinding and auto-centering
- Screw on clamping system: Easy to replace insert
- Edge design with excellent centering: Low cutting load and good chip control
- High durability holder: Improved wear resistance and durability with special surface treatment implementation
- Holder with good chip evacuation: Good chip evacuation and reduced cutting load with high helix angle
- Optimally designed oil hole: Long tool life

Code system of holder



Code system of insert

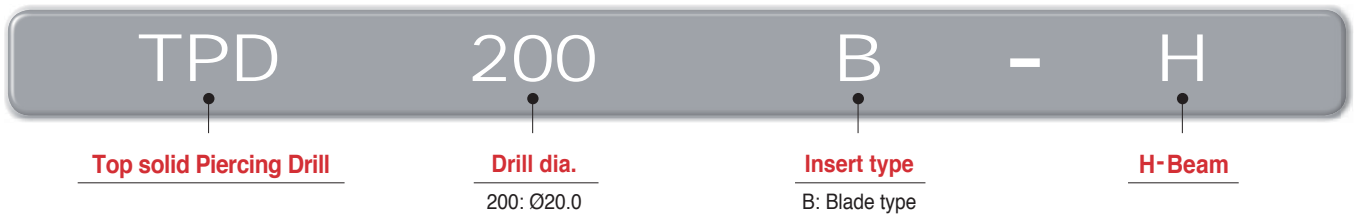

Features of insert

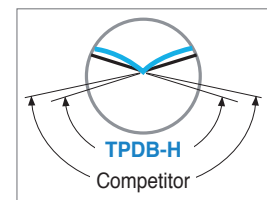
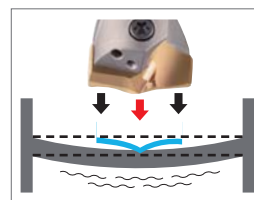
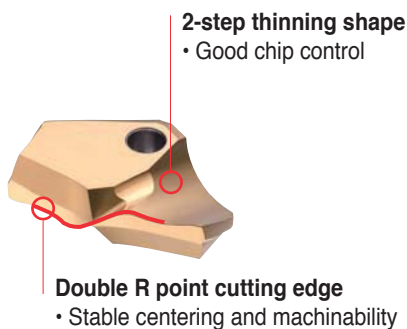

- ↓ Applied Double R point edge design is optimized for excellent centering and stable machinability
- ↓ Machinability and productivity are improved by minimizing both workpiece's bending and chipping at edge corner section

Features of holder

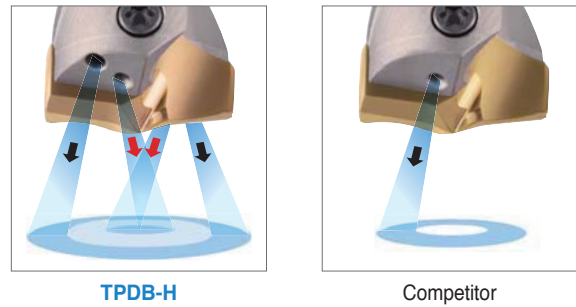
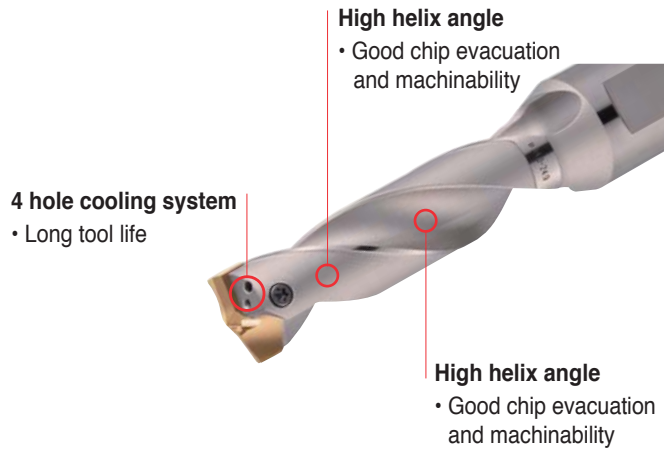

↓ ↓ Concentrated coolant injection on delicate cutting edge increases tool life

Grade selection

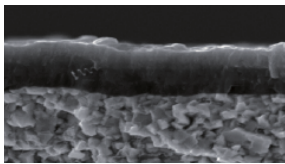

• PC340Q

- Application of high hardness lubricative PVD coating technology with excellent resistance on wear, welding, and chipping
- The special surface treatment improves chip evacuation and reduces wear on the rake surface and relief face
- High hardness ultra-fine substrate ensures high rigidity of cutting edge and good chipping resistance

Performance evaluation

Chip control

- **Workpiece** Carbon steel (SS400, SM490A)
- **Cutting conditions** Drill dia.(mm) = Ø27, vc (m/min) = 80
fn (mm/rev) = 0.2, ap (mm) = 30, wet
- **Tools** Inserts TPD270B-H (PC340Q)
Holder TPDB270-32-4-H



SS400



SM490A



Wear resistance

- **Workpiece** Carbon steel (SS400)
- **Cutting conditions** Drill dia.(mm) = Ø22, vc (m/min) = 65
fn (mm/rev) = 0.25, ap (mm) = 30, wet
- **Tools** Inserts TPD220B-H (PC340Q)
Holder TPDB220-25-4-H

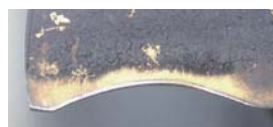

SS400

- **Workpiece** Carbon steel (SM490A)
- **Cutting conditions** Drill dia.(mm) = Ø27, vc (m/min) = 70
fn (mm/rev) = 0.25, ap (mm) = 30, wet
- **Tools** Inserts TPD270B-H (PC340Q)
Holder TPDB270-32-4-H





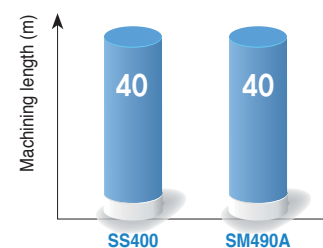

SM490A

■ Test result



Normal wear and still usable

Workpiece and recommended cutting conditions

Workpiece			Grade	vc (m/min)	Aspect ratio (L/D) = 3D, 4D Feed rate (mm/rev) per drill dia. (mm)		
ISO	Workpiece	Workpiece materials			Ø14.0~Ø21.0	Ø22.0~Ø30.0	
P	H-Beam		SS400 SM490 SHN490	PC340Q	65 (60~75)	0.22 (0.2~0.25)	0.25 (0.2~0.3)
	Angle		SS400 SM490 SHN490	PC340Q	65 (60~75)	0.22 (0.2~0.25)	0.25 (0.2~0.3)
	Plate		SS400 SM490 SHN490	PC340Q	65 (60~75)	0.22 (0.2~0.25)	0.25 (0.2~0.3)
	Plate (Stacked)		SS400 SM490 SHN490	PC340Q	60 (55~65)	0.2 (0.15~0.25)	0.2 (0.15~0.25)

How to clamp a TPDB-H insert

Clamping an insert to a holder



- ① Put an insert on the tip seat of the holder
- ② As the [pic.1], push the insert to the v-shaped groove of the holder
- ③ Screw and clamp the insert

Changing the used insert to a new one



- ① Unscrew and separate the used insert from the holder
- ② As the [Pic.2], clean the insert seat
- ③ Put a new insert on the tip seat
- ④ As the [pic.3], clamp the insert pushing it with a hand not to separate from the holder

Precaution in drilling

Drilling of angled entrance



1. The approach angle between drill and the workpiece at the beginning should be less than 6°
2. Reduce the feed to 30~50% than general cutting conditions at the beginning and the end of angled surface.

Drilling of stacked plates



1. Gap between the plates could make wrong chip evacuation causing fracture of the drill.
2. Place stacked plates without any gap between each

Plunging



1. Irregular cutting resistance in plunging could cause fracture and deformation of the drill.

Boring



1. Boring is not recommended due to wear and chipping in the corner of the insert.

TPDB-H Insert **new**

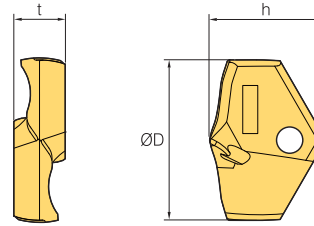
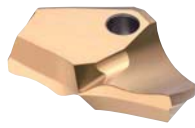

Designation		Coated PC340Q	ØD	h	t
TPD	140B-H~149B-H		14.0-14.9	10.0	4.0
	150B-H~159B-H		15.0-15.9	10.5	4.0
	160B-H~169B-H		16.0-16.9	11.5	5.5
	170B-H~179B-H		17.0-17.9	12.0	5.5
	180B-H~189B-H		18.0-18.9	13.0	6.0
	190B-H~199B-H		19.0-19.9	13.5	6.0
	200B-H~209B-H		20.0-20.9	14.5	6.5
	210B-H~219B-H		21.0-21.9	15.0	6.5
	220B-H~229B-H		22.0-22.9	15.5	7.0
	230B-H~239B-H		23.0-23.9	16.0	7.0
	240B-H~249B-H		24.0-24.9	16.5	7.5
	250B-H~259B-H		25.0-25.9	17.0	7.5
	260B-H~269B-H		26.0-26.9	17.5	8.5
	270B-H~279B-H		27.0-27.9	18.5	8.5
	280B-H~289B-H		28.0-28.9	19.5	9.5
	290B-H~299B-H		29.0-29.9	20.0	9.5
300B-H~309B-H		30.0-30.9	20.5	10.0	

(mm)

● : Stock Item

Parts

Designation	Drill dia. (ØD)	Screw	Wrench	Torque (N·m)	
TPD	140B-H~149B-H	14.0-14.9	FTNB02512-P	TW07S	0.8
	150B-H~179B-H	15.0-17.9	FTNB02514-P	TW07S	0.8
	180B-H~199B-H	18.0-19.9	FTNB0316-P	TW09S	1.2
	200B-H~239B-H	20.0-23.9	FTNB0319	TW09S	1.2
	240B-H~259B-H	24.0-25.9	FTNB03522	TW15S	3.0
	260B-H~279B-H	26.0-27.9	FTNB03524	TW15S	3.0
	280B-H~299B-H	28.0-29.9	FTNB0426	TW15S	3.0
	300B-H~309B-H	30.0-30.9	FTNB0528	TW20-100	4.0

(mm)

TPDB-H (3D) new

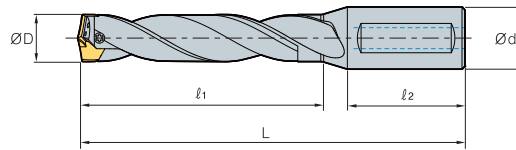

(mm)

Designation	ØD	Ød	l ₁	l ₂	L	Insert	
TPDB	140-16-3-H	14.0-14.4	16	42	48	97.5	TPD140B-144B-H
	145-16-3-H	14.5-14.9	16	43.5	48	99.5	TPD145B-149B-H
	150-20-3-H	15.0-15.4	20	45	50	103.0	TPD150B-154B-H
	155-20-3-H	15.5-15.9	20	46.5	50	105.0	TPD155B-159B-H
	160-20-3-H	16.0-16.4	20	48	50	106.5	TPD160B-164B-H
	165-20-3-H	16.5-16.9	20	49.5	50	108.5	TPD165B-169B-H
	170-20-3-H	17.0-17.4	20	51	50	110.0	TPD170B-174B-H
	175-20-3-H	17.5-17.9	20	52.5	50	112.0	TPD175B-179B-H
	180-20-3-H	18.0-18.4	20	54	50	113.5	TPD180B-184B-H
	185-20-3-H	18.5-18.9	20	55.5	50	115.5	TPD185B-189B-H
	190-20-3-H	19.0-19.4	20	57	50	117.0	TPD190B-194B-H
	195-20-3-H	19.5-19.9	20	58.5	50	119.0	TPD195B-199B-H
	200-25-3-H	20.0-20.4	25	60	56	126.5	TPD200B-204B-H
	205-25-3-H	20.5-20.9	25	61.5	56	128.5	TPD205B-209B-H
	210-25-3-H	21.0-21.4	25	63	56	130.0	TPD210B-214B-H
	215-25-3-H	21.5-21.9	25	64.5	56	132.0	TPD215B-219B-H
	220-25-3-H	22.0-22.4	25	66	56	133.5	TPD220B-224B-H
	225-25-3-H	22.5-22.9	25	67.5	56	135.5	TPD225B-229B-H
	230-25-3-H	23.0-23.4	25	69	56	137.0	TPD230B-234B-H
	235-25-3-H	23.5-23.9	25	70.5	56	139.0	TPD235B-239B-H
	240-32-3-H	24.0-24.4	32	72	60	144.5	TPD240B-244B-H
	245-32-3-H	24.5-24.9	32	73.5	60	146.5	TPD245B-249B-H
	250-32-3-H	25.0-25.4	32	75	60	148.0	TPD250B-254B-H
	255-32-3-H	25.5-25.9	32	76.5	60	150.0	TPD255B-259B-H
	260-32-3-H	26.0-26.4	32	78	60	151.5	TPD260B-264B-H
	265-32-3-H	26.5-26.9	32	79.5	60	153.5	TPD265B-269B-H
	270-32-3-H	27.0-27.4	32	81	60	155.0	TPD270B-274B-H
	275-32-3-H	27.5-27.9	32	82.5	60	157.0	TPD275B-279B-H
	280-32-3-H	28.0-28.4	32	84	60	158.5	TPD280B-284B-H
	285-32-3-H	28.5-28.9	32	85.5	60	160.5	TPD285B-289B-H
290-32-3-H	29.0-29.4	32	87	60	162.0	TPD290B-294B-H	
295-32-3-H	29.5-29.9	32	88.5	60	164.0	TPD295B-299B-H	
300-32-3-H	30.0-30.4	32	90	60	165.5	TPD300B-304B-H	

↻ Applicable inserts **G47**



TPDB-H (4D) new

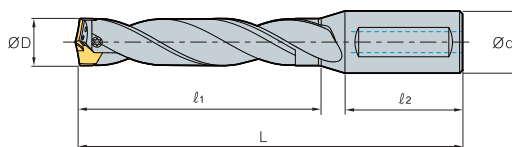

		(mm)					
	Designation	ØD	Ød	l ₁	l ₂	L	Insert
TPDB	140-16-4-H	14.0-14.4	16	56	48	111.5	TPD140B-144B-H
	145-16-4-H	14.5-14.9	16	58	48	114.0	TPD145B-149B-H
	150-20-4-H	15.0-15.4	20	60	50	118.0	TPD150B-154B-H
	155-20-4-H	15.5-15.9	20	62	50	120.5	TPD155B-159B-H
	160-20-4-H	16.0-16.4	20	64	50	122.5	TPD160B-164B-H
	165-20-4-H	16.5-16.9	20	66	50	125.0	TPD165B-169B-H
	170-20-4-H	17.0-17.4	20	68	50	127.0	TPD170B-174B-H
	175-20-4-H	17.5-17.9	20	70	50	129.5	TPD175B-179B-H
	180-20-4-H	18.0-18.4	20	72	50	131.5	TPD180B-184B-H
	185-20-4-H	18.5-18.9	20	74	50	134.0	TPD185B-189B-H
	190-20-4-H	19.0-19.4	20	76	50	136.0	TPD190B-194B-H
	195-20-4-H	19.5-19.9	20	78	50	138.5	TPD195B-199B-H
	200-25-4-H	20.0-20.4	25	80	56	146.5	TPD200B-204B-H
	205-25-4-H	20.5-20.9	25	82	56	149.0	TPD205B-209B-H
	210-25-4-H	21.0-21.4	25	84	56	151.0	TPD210B-214B-H
	215-25-4-H	21.5-21.9	25	86	56	153.5	TPD215B-219B-H
	220-25-4-H	22.0-22.4	25	88	56	155.5	TPD220B-224B-H
	225-25-4-H	22.5-22.9	25	90	56	158.0	TPD225B-229B-H
	230-25-4-H	23.0-23.4	25	92	56	160.0	TPD230B-234B-H
	235-25-4-H	23.5-23.9	25	94	56	162.5	TPD235B-239B-H
	240-32-4-H	24.0-24.4	32	96	60	168.5	TPD240B-244B-H
	245-32-4-H	24.5-24.9	32	98	60	171.0	TPD245B-249B-H
	250-32-4-H	25.0-25.4	32	100	60	173.0	TPD250B-254B-H
	255-32-4-H	25.5-25.9	32	102	60	175.5	TPD255B-259B-H
	260-32-4-H	26.0-26.4	32	104	60	177.5	TPD260B-264B-H
	265-32-4-H	26.5-26.9	32	106	60	180.0	TPD265B-269B-H
	270-32-4-H	27.0-27.4	32	108	60	182.0	TPD270B-274B-H
	275-32-4-H	27.5-27.9	32	110	60	184.5	TPD275B-279B-H
	280-32-4-H	28.0-28.4	32	112	60	186.5	TPD280B-284B-H
	285-32-4-H	28.5-28.9	32	114	60	189.0	TPD285B-289B-H
	290-32-4-H	29.0-29.4	32	116	60	191.0	TPD290B-294B-H
	295-32-4-H	29.5-29.9	32	118	60	193.5	TPD295B-299B-H
300-32-4-H	30.0-30.4	32	120	60	195.5	TPD300B-304B-H	

➔ Applicable inserts **G47**

TPDB-H (8D) new

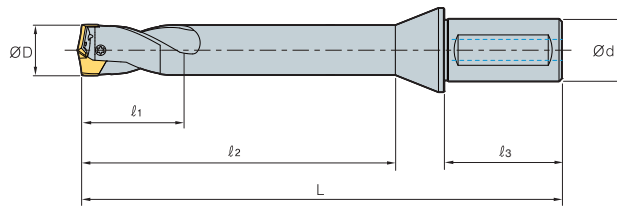

(mm)

Designation	ØD	Ød	l ₁	l ₂	l ₃	L	Insert	
TPDB	140-16-8F-H	14.0-14.4	16	50	112	48	175.0	TPD140B-144B-H
	145-16-8F-H	14.5-14.9	16	50	116	48	179.0	TPD145B-149B-H
	150-20-8F-H	15.0-15.4	20	50	120	50	186.0	TPD150B-154B-H
	155-20-8F-H	15.5-15.9	20	50	124	50	190.0	TPD155B-159B-H
	160-20-8F-H	16.0-16.4	20	50	128	50	195.0	TPD160B-164B-H
	165-20-8F-H	16.5-16.9	20	50	132	50	199.0	TPD165B-169B-H
	170-20-8F-H	17.0-17.4	20	50	136	50	204.0	TPD170B-174B-H
	175-20-8F-H	17.5-17.9	20	50	140	50	208.0	TPD175B-179B-H
	180-20-8F-H	18.0-18.4	20	50	144	50	214.0	TPD180B-184B-H
	185-20-8F-H	18.5-18.9	20	50	148	50	218.0	TPD185B-189B-H
	190-20-8F-H	19.0-19.4	20	50	152	50	222.0	TPD190B-194B-H
	195-20-8F-H	19.5-19.9	20	50	156	50	226.0	TPD195B-199B-H
	200-25-8F-H	20.0-20.4	25	50	160	56	236.0	TPD200B-204B-H
	205-25-8F-H	20.5-20.9	25	50	164	56	240.0	TPD205B-209B-H
	210-25-8F-H	21.0-21.4	25	50	168	56	244.0	TPD210B-214B-H
	215-25-8F-H	21.5-21.9	25	50	172	56	248.0	TPD215B-219B-H
	220-25-8F-H	22.0-22.4	25	50	176	56	252.0	TPD220B-224B-H
	225-25-8F-H	22.5-22.9	25	50	180	56	261.0	TPD225B-229B-H
	230-25-8F-H	23.0-23.4	25	50	184	56	265.0	TPD230B-234B-H
	235-25-8F-H	23.5-23.9	25	50	188	56	269.0	TPD235B-239B-H
	240-32-8F-H	24.0-24.4	32	50	192	60	277.0	TPD240B-244B-H
	245-32-8F-H	24.5-24.9	32	50	196	60	281.0	TPD245B-249B-H
	250-32-8F-H	25.0-25.4	32	50	200	60	285.0	TPD250B-254B-H
	255-32-8F-H	25.5-25.9	32	50	204	60	289.0	TPD255B-259B-H
	260-32-8F-H	26.0-26.4	32	50	208	60	293.0	TPD260B-264B-H
	265-32-8F-H	26.5-26.9	32	50	212	60	297.0	TPD265B-269B-H
	270-32-8F-H	27.0-27.4	32	50	216	60	301.0	TPD270B-274B-H
	275-32-8F-H	27.5-27.9	32	50	220	60	305.0	TPD275B-279B-H
	280-32-8F-H	28.0-28.4	32	50	224	60	311.0	TPD280B-284B-H
	285-32-8F-H	28.5-28.9	32	50	228	60	315.0	TPD285B-289B-H
290-32-8F-H	29.0-29.4	32	50	232	60	320.0	TPD290B-294B-H	
295-32-8F-H	29.5-29.9	32	50	236	60	324.0	TPD295B-299B-H	
300-32-8F-H	30.0-30.4	32	50	240	60	328.0	TPD300B-304B-H	

↻ Applicable inserts **G47**

• The max. length of flute could be l₂



Convenient and quickly adjustable drill height

WPDC

Indexable Drill Clamped with Center Drill

Code system for drill

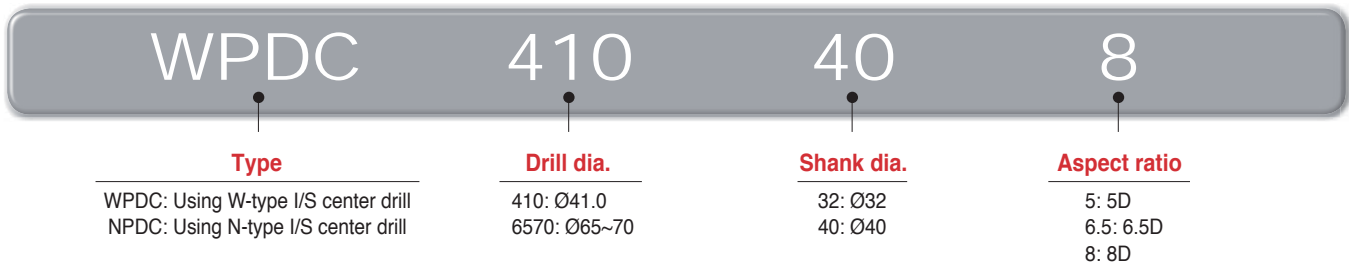

Code system for cartridge



Code system for center drill

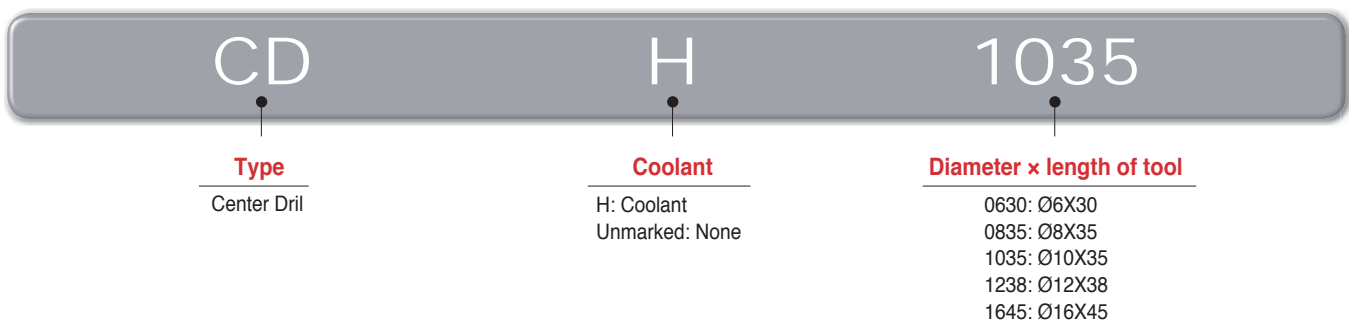

Grade of center drill



How to clamp the drills

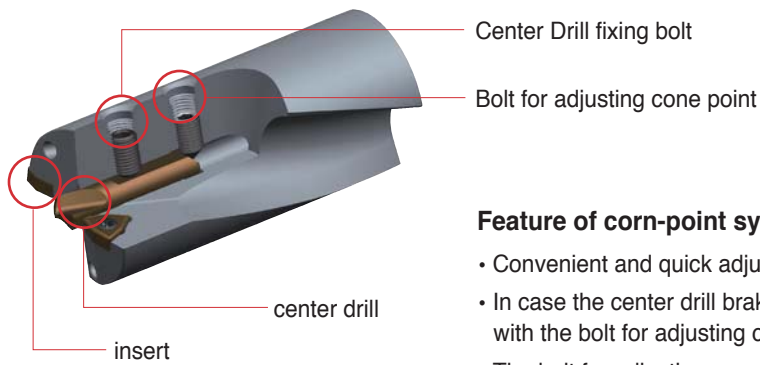

Feature of corn-point system

- Convenient and quick adjustable heights when inserting the center drill
- In case the center drill brakes while in usage, it can be replaced with the bolt for adjusting cone point
- The bolt for adjusting cone point prevents chattering on the center drill

Clamping

1	2	3	4	5
Place a center drill	Clamp insert and cartridge	Adjust the center drill with the bolt for adjusting cone point	Clamp the center drill firmly with fixing bolt	Reassure the clamp with bolt for adjusting cone point

- ※ Use safety covers for your safety when clamping the center drill and insert
- ※ When machining, be careful of the drill disk

Length of the 'a' part of center drill

The length of 'a' being too short can cause bad surface finish or high cutting load
 On the other hand, the length of 'a' being too long can make tool failure and chattering while drilling

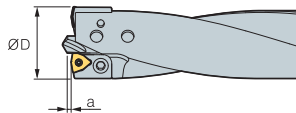

Diameter (ØD)	Length of the 'a' part of center drill		
	Steel	Alloy steel	Non-ferrous metal
25~30	1.2	1.0	1.5
31~40	1.5	1.3	1.8
41~50	1.8	1.5	2.2
51~59	2.2	1.8	2.5
60~75	2.5	2.0	2.8
76~80	3.0	2.5	3.5



Adjusting diameter of cartridge type drill

- Disassemble a cartridge from the holder by loosening the bolt fixed for outer cartridge
- Machine after calculating the hole size on the side of the outer cartridge
- Trim the sharp part after machining
- Clamp the bolt for fixing cartridge without any gap in between the holder and the machined outer cartridge

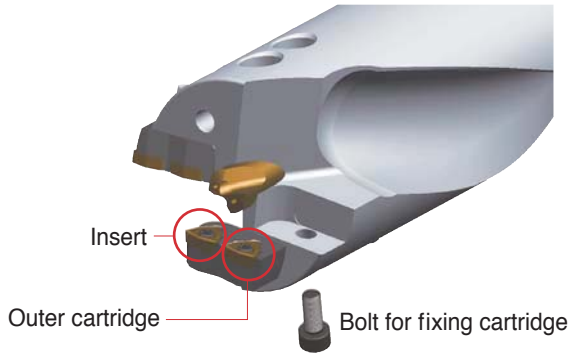

- **Range of adjustable drill diameter**
 1. Single cartridge type (Drill diameter $\varnothing 41\sim\varnothing 59$) \rightsquigarrow -1.0 mm
 2. Dual cartridge type (Drill diameter $\varnothing 60\sim\varnothing 80$) \rightsquigarrow -5.0 mm
- **Diameter of the standard drills is provided with maximum size of standards**
 Ex) WPDC6570-40-6.5 \rightsquigarrow Drill diameter 70.0 mm

Ex) How to adjust drill diameter to $\varnothing 66.0$ machining with WPDC6570-40-8

\rightsquigarrow To make the drill diameter of outer cartridge to $\varnothing 66.0$, machine 2.0 mm. ($\varnothing 70.0 - \varnothing 66.0 = 4 \rightsquigarrow 4 \div 2 = 2$ (radius))

Recommended cutting condition

Workpiece			Chip breaker	Grade	vc (m/min)	Aspect ratio (L/D) = 5D, 6.5D, 8D						
ISO	Workpiece	HB				Feed rate (mm/rev) per drill dia. (mm)						
						$\sim\varnothing 30$	$\varnothing 31\sim\varnothing 40$	$\varnothing 41\sim\varnothing 50$	$\varnothing 51\sim\varnothing 59$	$\varnothing 60\sim\varnothing 75$	$\varnothing 76\sim\varnothing 80$	
P	Carbon steel	Low carbon steel (~0.25%)	80~180	C21N	PC5335	190 (160~220)	0.07~0.11	0.08~0.12	0.10~0.14	0.12~0.16	0.12~0.16	0.12~0.16
		High carbon steel (0.25%~)	180~280	C21N	PC5335	140 (110~170)	0.07~0.11	0.08~0.12	0.10~0.14	0.12~0.16	0.12~0.16	0.12~0.16
	Alloy steel	Low alloy steel	140~260	C21N	PC5335	130 (100~160)	0.08~0.12	0.08~0.12	0.10~0.14	0.12~0.18	0.12~0.18	0.12~0.18
		High alloy steel	50~260	C21N	PC5335	100 (70~130)	0.06~0.10	0.08~0.12	0.08~0.12	0.10~0.16	0.10~0.16	0.10~0.16
M	Stainless steel	Stainless steel	135~275	C21N	PC5335	100 (70~130)	0.06~0.10	0.08~0.12	0.10~0.12	0.12~0.14	0.12~0.14	0.12~0.14
K	Cast iron	Gray cast iron	150~220	C21N	PC5335	160 (130~190)	0.09~0.15	0.10~0.16	0.12~0.2	0.14~0.22	0.14~0.22	0.14~0.22
		Ductile cast iron	200~300	C21N	PC5335	140 (170~110)	0.09~0.15	0.10~0.16	0.12~0.2	0.14~0.22	0.14~0.22	0.14~0.22
		Malleable cast iron	130~230	C21N	PC5335	150 (180~120)	0.09~0.15	0.10~0.16	0.12~0.2	0.14~0.22	0.14~0.22	0.14~0.22
N	Aluminum	Aluminum	30~150	C21N	PC5335	300 (250~350)	0.08~0.12	0.10~0.14	0.12~0.16	0.14~0.18	0.14~0.18	0.14~0.18
	Alloyed copper	Alloyed copper	150~160	C21N	PC5335	250 (200~300)	0.08~0.12	0.10~0.14	0.12~0.16	0.14~0.18	0.14~0.18	0.14~0.18
S	Heat resistant alloy	Heat resistant alloy	130~400	C21N	PC5335	50 (70~30)	0.05~0.08	0.05~0.08	0.06~0.10	0.06~0.10	0.06~0.10	0.06~0.10

Parts of WPDC type indexable drills

Designation	ØD	Insert			Center drill			Cartridge			
		Insert	Screw	Wrench	Center drill	fixed bolt	cone point bolt	Inner	Outer	Fixed bolt	
WPDC250-32-□	25	WC□T030204-C21N	FTKA02206	TW06S	CD0630	KHA0508	KHC0510	CWP4145C	CWP430P	BHA0510	
WPDC260~280-32-□	26~28	WC□T040204-C21N	FTNA02555	TW07S		KHA0510					
WPDC290~300-32-□	29~30					WC□T050308-C21N	FTKA0307				TW09S
WPDC310~350-32-□	31~35	KHA0612	KHC0610	CDH1035	KHA0812				KHC0812	CWP4650C	
WPDC360~400-32-□	36~40					WC□T06T308-C21N	FTKA03508				TW15S
WPDC410-40-□	41	WC□T080408-C21N	FTKA0411K		TW15S				KHA1015	KHC1016	
WPDC420-40-□	42					CDH1238	KHA1015				KHC1016
WPDC430-40-□	43	WC□T050308-C21N	FTKA0307		TW09S				KHA1020	KHA1020	
WPDC440-40-□	44					WC□T06T308-C21N	FTKA03508				TW15S
WPDC450-40-□	45	WC□T06T308-C21N	FTKA03508		TW15S				CDH1645	KHA1020	
WPDC460-40-□	46					WC□T06T308-C21N	FTKA03508	TW15S			CDH1645
WPDC470-40-□	47	WC□T06T308-C21N	FTKA03508		TW15S				CDH1645	KHA1020	
WPDC480-40-□	48					WC□T06T308-C21N	FTKA03508	TW15S			CDH1645
WPDC490-40-□	49	WC□T06T308-C21N	FTKA03508	TW15S	CDH1645				KHA1020	KHA1020	
WPDC500-40-□	50					WC□T06T308-C21N	FTKA03508	TW15S			CDH1645
WPDC510-40-□	51	WC□T06T308-C21N	FTKA03508	TW15S	CDH1645				KHA1020	KHA1020	
WPDC520-40-□	52					WC□T06T308-C21N	FTKA03508	TW15S			CDH1645
WPDC530-40-□	53	WC□T06T308-C21N	FTKA03508	TW15S	CDH1645				KHA1020	KHA1020	
WPDC540-40-□	54					WC□T06T308-C21N	FTKA03508	TW15S			CDH1645
WPDC550-40-□	55	WC□T06T308-C21N	FTKA03508	TW15S	CDH1645				KHA1020	KHA1020	
WPDC560-40-□	56					WC□T06T308-C21N	FTKA03508	TW15S			CDH1645
WPDC570-40-□	57	WC□T06T308-C21N	FTKA03508	TW15S	CDH1645				KHA1020	KHA1020	
WPDC580-40-□	58					WC□T06T308-C21N	FTKA03508	TW15S			CDH1645
WPDC590-40-□	59	WC□T06T308-C21N	FTKA03508	TW15S	CDH1645				KHA1020	KHA1020	
WPDC6065-40-□	60~65					WC□T06T308-C21N	FTKA03508	TW15S			CDH1645
WPDC6570-40-□	65~70	WC□T06T308-C21N	FTKA03508	TW15S	CDH1645				KHA1020	KHA1020	
WPDC7075-40-□	70~75					WC□T06T308-C21N	FTKA03508	TW15S			CDH1645
WPDC7580-40-□	75~80	WC□T06T308-C21N	FTKA03508	TW15S	CDH1645				KHA1020	KHA1020	

↻ Applicable inserts G04~05

Center Drill

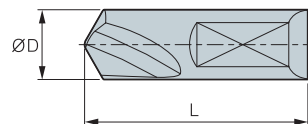

(mm)

Designation	Grade	ØD	L	Oil-hole
CD0630	PC40H	6	30	×
CD0835	PC40H	8	35	×
CDH1035	PC40H	10	35	○
CDH1238	PC40H	12	38	○
CDH1645	PC40H	16	45	○

• This is HSS with Tin coating



WPDC (5D/6.5D/8D)

Standard type

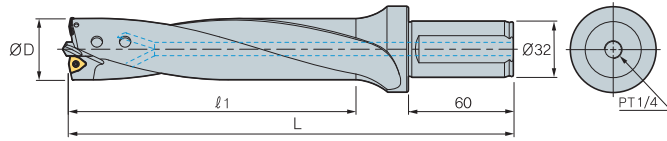

(mm)

Designation	ØD	5D		6.5D		8D		Insert	Center drill
		l ₁	L	l ₁	L	l ₁	L		
WPDC 250-32-□	25	150	240	185	275	220	310	WC□T030204-C21N	CD0630
260-32-□	26	150	240	185	275	220	310		
270-32-□	27	150	240	185	275	220	310		
280-32-□	28	150	240	185	275	220	310		
290-32-□	29	150	240	185	275	220	310		
300-32-□	30	150	240	185	275	220	310		
310-32-□	31	175	265	218	308	260	350	WC□T050308-C21N	CD0835
320-32-□	32	175	265	218	308	260	350		
330-32-□	33	175	265	218	308	260	350		
340-32-□	34	175	265	218	308	260	350		
350-32-□	35	175	265	218	308	260	350		
360-32-□	36	200	290	250	340	300	390		
370-32-□	37	200	290	250	340	300	390		
380-32-□	38	200	290	250	340	300	390		
390-32-□	39	200	290	250	340	300	390		
400-32-□	40	200	290	250	340	300	390		

Applicable inserts **G04-05**

* We can provide if you order exact diameter
Ex) machining hole 32.5 mm + 6.5D → WPDC325-32-6.5

WPDC (5D/6.5D/8D)

Single insert cartridge type

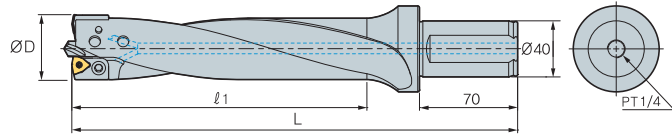

(mm)

Designation	ØD	5D		6.5D		8D		Insert	Center drill	Cartridge			
		l ₁	L	l ₁	L	l ₁	L			Inner	Outer		
WPDC 410-40-□	41	225	330	283	388	340	445	WC□T06T308-C21N	CDH1035	CWP4145C	CWP410P		
420-40-□	42	225	330	283	388	340	445				CWP420P		
430-40-□	43	225	330	283	388	340	445				CWP430P		
440-40-□	44	225	330	283	388	340	445				CWP440P		
450-40-□	45	225	330	283	388	340	445				CWP450P		
460-40-□	46	250	355	315	420	380	485			CWP4650C	CWP460P		
470-40-□	47	250	355	315	420	380	485				CWP470P		
480-40-□	48	250	355	315	420	380	485				CWP480P		
490-40-□	49	250	355	315	420	380	485				CWP490P		
500-40-□	50	250	355	315	420	380	485				CWP500P		
510-40-□	51	275	380	348	453	420	525			WC□T080408-C21N	CDH1238	CWP5155C	CWP510P
520-40-□	52	275	380	348	453	420	525						CWP520P
530-40-□	53	275	380	348	453	420	525						CWP530P
540-40-□	54	275	380	348	453	420	525						CWP540P
550-40-□	55	275	380	348	453	420	525	CWP550P					
560-40-□	56	300	405	380	485	460	565	WC□T080408-C21N	CDH1238	CWP5659C	CWP560P		
570-40-□	57	300	405	380	485	460	565				CWP570P		
580-40-□	58	300	405	380	485	460	565				CWP580P		
590-40-□	59	300	405	380	485	460	565				CWP590P		

↻ Applicable inserts G04~05

* We can provide if you order exact diameter
Ex) machining hole 47.5 mm * 5D -> WPDC475-40-5

WPDC (5D/6.5D/8D)

Dual insert cartridge type

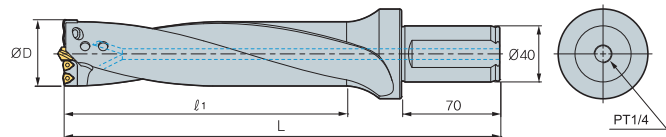

(mm)

Designation	ØD	5D		6.5D		8D		Insert	Center drill	Cartridge	
		l ₁	L	l ₁	L	l ₁	L			Inner	Outer
WPDC 6065-40-□	60~65	325	430	423	528	520	625	WC□T050308-C21N	CDH1238	CWP6065C	CWP6065P
6570-40-□	65~70	350	455	455	560	560	665			CWP6570C	CWP6570P
7075-40-□	70~75	375	480	488	593	600	705			CWP7075C	CWP7075P
7580-40-□	75~80	400	505	520	625	640	745	WC□T06T308-C21N	CDH1645	CWP7580C	CWP7580P

↻ Applicable inserts G04~05

* We can provide if you order exact diameter
Ex) machining hole 70.5 mm * 6.5D -> WPDC705-40-6.5



L

TECHNICAL INFORMATION

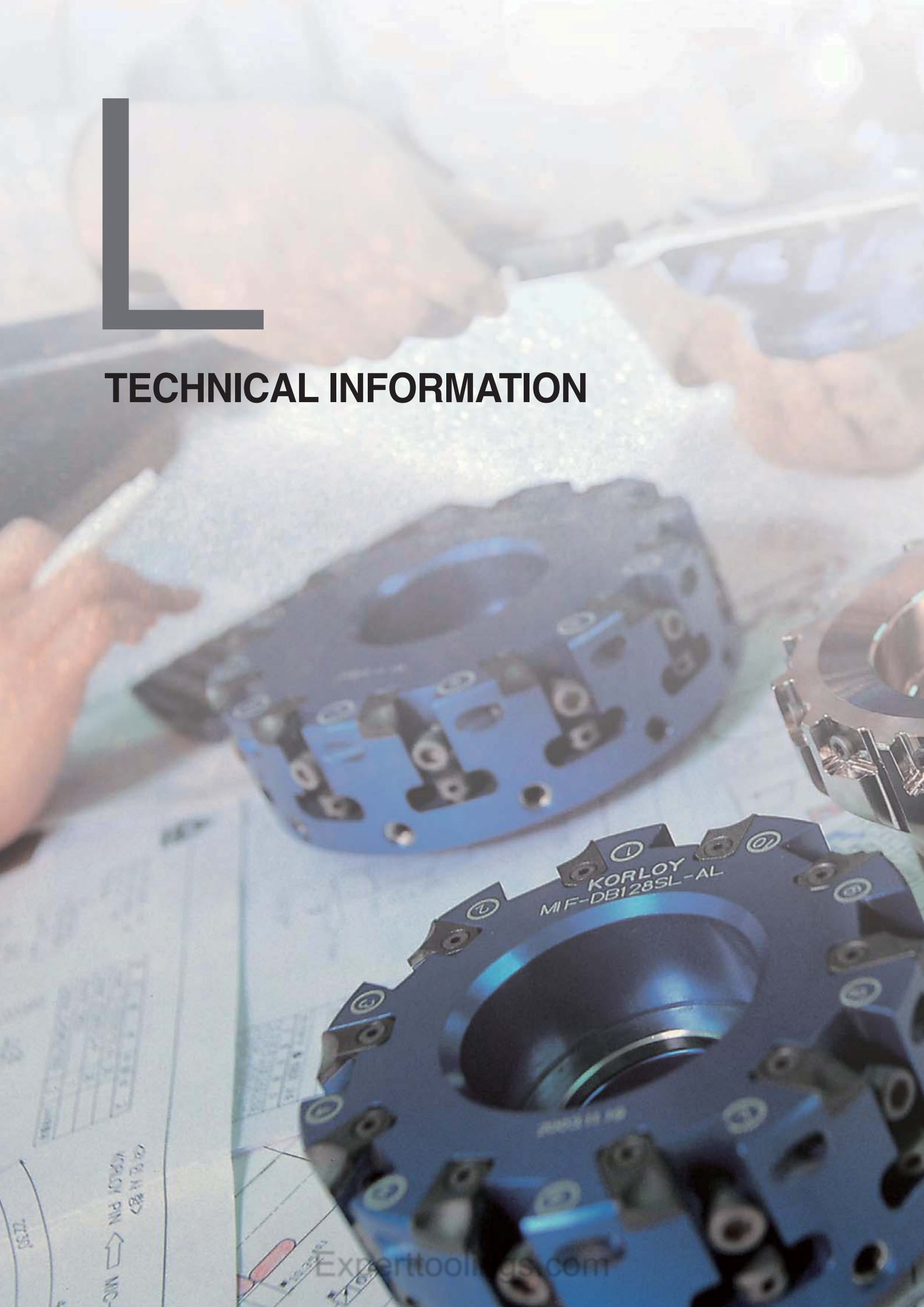

➤ The shape of drills and the names

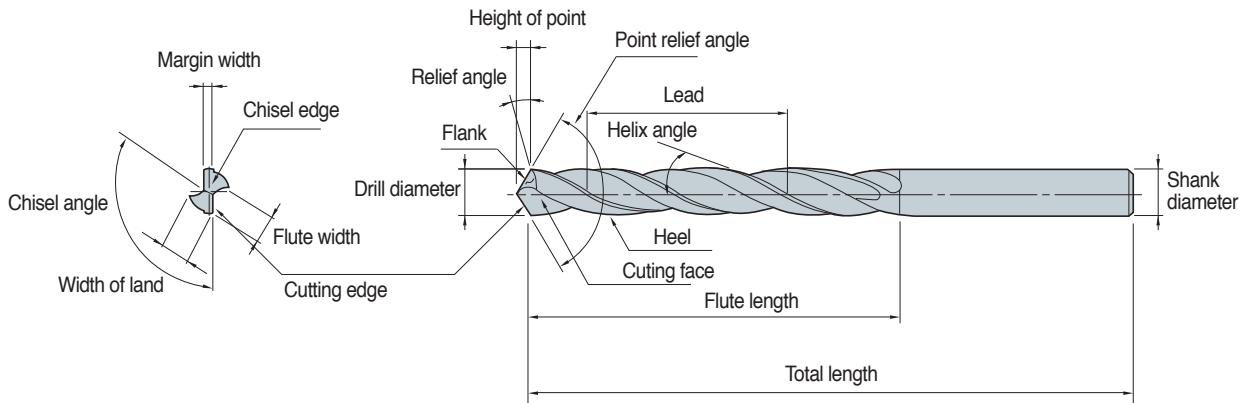

➤ Shape and the feature of cutting

Helix angle	<p>Plays rake angle of cutting edge's role. If helix angle increases Cutting force decreases. On the other hand If helix angle is too big Drill rigidity decreases</p> <p>Poor machinability ◀ low - Helix angle - high ▶ Hard workpiece (hardened steel) ▶ soft material (aluminum etc)</p>												
Length of flute	<p>The path of both chip evacuation and cooling lubricant</p> <p>Too big length of flute weakens drill rigidity and too small length of flute worsens chip evacuation to breakage</p>												
Point angle	<p>Point angle has big influence on cutting performance. It mainly depends on workpiece. In case of standard drills Point angle is generally 118</p> <p>thrust resistance decrease ◀ low - Point angle - high ▶ thrust resistance increase Torque increase, Burr on exit increase ▶ soft material (aluminum etc) ▶ Hard workpiece (hardened steel) Soft material (aluminum etc) ▶ Hard workpiece (hardened steel)</p>												
Margin	<p>While machining Margin is the part of contact between workpiece and drill's external. It prevents bending and plays guide's role It depends on drill size</p> <p>Cutting force decrease ◀ small - Margin - big ▶ Cutting force increase Poor guide ▶ Good guide</p>												
Web thickness	<p>Web is the part of center of drill and drill's rigidity depends on the web. Drill needs cutting edge, chisel edge, at the tip of drill because drill makes a hole at the beginning of drilling . When web thickness is big Thinning is needed to reduce cutting force</p> <p>Cutting force decrease ◀ small - Web thickness - big ▶ Cutting force increase Rigidity decrease ▶ Rigidity increase Good chip evacuation ▶ Bad chip evacuation Soft material (aluminum etc) ▶ Hard workpiece (hardened steel)</p>												
Back taper	<p>Drill diameter size is getting smaller from point to shank in order to avoid the friction between drill periphery and workpiece. The decrease of diameter divided by flute length 100mm generally becomes 0.04~0.1mm. As for high performance drills and drills for hole shrinkage workpiece during operation have big back taper</p>												
Thinning	<p>In general drills Thrust effects on chisel over 50%. Chisel edge length depends on web thickness and chisel angle. But if web is thin Drill rigidity weaken. Therefore without web thickness change Thinning makes chisel edge short or gives rake angle. In other words, Thinning makes rake angle at chisel and improves chip evacuation and decrease thrust</p> <table border="1" style="width: 100%; border-collapse: collapse;"> <thead> <tr> <th style="width: 20%;">Types of</th> <th style="width: 20%;">Edge shape</th> <th style="width: 30%;">Feature</th> <th style="width: 30%;">Korloy's drills</th> </tr> </thead> <tbody> <tr> <td style="text-align: center;">X type</td> <td style="text-align: center;"></td> <td> Good centering High central thickness Crank shaft </td> <td> Mach solid drill (MSD) Vulcan drill (VZD) </td> </tr> <tr> <td style="text-align: center;">S type</td> <td style="text-align: center;"></td> <td> For wide use For general Easy regrinding </td> <td style="text-align: center;">Solid drill (SSD)</td> </tr> </tbody> </table>	Types of	Edge shape	Feature	Korloy's drills	X type		Good centering High central thickness Crank shaft	Mach solid drill (MSD) Vulcan drill (VZD)	S type		For wide use For general Easy regrinding	Solid drill (SSD)
Types of	Edge shape	Feature	Korloy's drills										
X type		Good centering High central thickness Crank shaft	Mach solid drill (MSD) Vulcan drill (VZD)										
S type		For wide use For general Easy regrinding	Solid drill (SSD)										

Major cutting formulas

Cutting speed	Feed	Helix angle	Machining time
$vc = \frac{\pi \cdot D \cdot n}{1000} \text{ (m/min)}$ <ul style="list-style-type: none"> vc: Cutting speed (m/min) D: Drill diameter (mm) n: Revolution per minute (min⁻¹) π: Circular constant (3.14) 	$fn = \frac{vf}{n} \text{ (mm/rev)}$ <ul style="list-style-type: none"> fn: Feed per revolution (mm/rev) vf: Feed per minute (mm/min) n: Revolution per minute (min⁻¹) 	$\delta = \tan^{-1} \left(\frac{\pi D}{L} \right)$ <ul style="list-style-type: none"> δ: Helix angle D: Drill diameter (mm) L: Lead (mm) π: Circular constant (3.14) 	$tc = \frac{ld}{n \cdot fn} \text{ (min)}$ <ul style="list-style-type: none"> tc: Machining time (min) n: Revolution per minute (min⁻¹) ld: Drilling time (mm) fn: Feed (mm/rev)

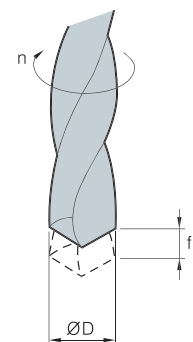

Cutting torque and thrust (calculation formulas)		
$Md = KD^2 \times (0.0631 + 1.686 \times fn) \text{ (kg·cm)}$ $T = 57.95KDfn^{0.88} \text{ (kg)}$	<ul style="list-style-type: none"> Md: Cutting torque (kg·cm) T: Cutting thrust (kg) D: Drill diameter (mm) 	<ul style="list-style-type: none"> fn: Feed per revolution (mm/rev) K: Material coefficient

Workpiece material (SAE/AISI)	Tensile strength (kgf)	Hardness (HB)	Material coefficient K	
Cast iron	Cast iron (Gray)	21	177	1.00
	Cast iron	28	198	1.39
	Cast iron (Ductile)	35	224	1.88
General steel	1020(carbon steel C 0.2%)	55	160	2.22
	1112(C 0.12, S 0.2%)	62	183	1.42
	1335(Mn 1.75%)	63	197	1.45
Nickel Chrome steel	3115 (Ni 1.25, Cr 0.6, Mn 0.5)	53	163	1.56
	3120 (Ni 1.25, Cr 0.6, Mn 0.7)	69	174	2.02
	3140	88	241	2.32
Chrome molybdenum steel	4115 (Cr 0.5, Mo 0.11, Mn 0.8)	63	167	1.62
	4130 (Cr 0.95, Mo 0.2, Mn 0.5)	77	229	2.10
	4140 (Cr 0.95, Mo 0.2, Mn 0.85)	94	269	2.41
Nickel molybdenum steel	4615 (Ni 1.8, Mo 0.25, Mn 0.5)	75	212	2.12
	4820 (Ni 3.5, Mo 0.25, Mn 0.6)	140	390	3.44
Chrome steel	5150 (Cr 0.8, Mn 0.8)	95	277	2.46
Chrome vanadium steel	6115 (Cr 0.6, Mn 0.6, V 0.12)	58	174	2.08
	6120 (Cr 0.8, Mn 0.8, V 0.1)	80	255	2.22

Cutting torque and thrust (empirical formula)			
$Md = K_1 d^2 \cdot fn^m$ $T = K_2 d \cdot fn^n$	<ul style="list-style-type: none"> Md: Cutting torque (kg·cm) T: Thrust (kg) 	<ul style="list-style-type: none"> fn: Feed (mm/rev) d: Drill diameter (mm) K₁, K₂, m, n: Experimental Data Characteristic value 	

Workpiece	K ₁	m	K ₂	n
Soft steel	5.9	1.00	125.0	0.88
Rolled steel	3.5	1.00	55.0	0.88
7-3 brass	2.5	0.94	44.4	0.87
Aluminum	1.5	0.90	33.3	0.78
Zinc	1.4	0.88	27.0	0.74
Gun metal	2.0	0.94	21.6	0.75
Galvanized iron	0.3	0.57	6.4	0.55

🔧 Tool failures and solutions

Trouble	Causes	Solutions																
		Cutting condition					Tool shape					Grade		etc				
		Cutting speed	Feed	Step feed	Initial feed	Coolant	Relief angle	Point angle	Thinning angle	Honing	Flute width rate	Thinning	Toughness	Hardness	Machine rigidity	Machine vibration	Guide bush	Clamping workpiece
Chipping	• Too sharp cutting edge (too big relief angle) (thinning edge is too sharp)						↓		↓	↑			↑					
	• Excessive cutting speed	↓				●												
	• Built-up edge					●	↓		↓	↑			↑					
	• Vibration and chattering	↓												↑	↓		●	
Wear	• Excessive cutting speed (Abnormal wear at margin)	↓				●												
	• Insufficient cutting speed (Abnormal wear at center)	↑				●												
Chip	• Long chip	↑	↑			●				↓								
	• Over lap	↑	↑															
	• Chip burning	↑				●												
Hole precision burr, poor surface finish	• Tool clamping precision				↓			↓		↓				↑	↓		●	
	• Excessive feed, sharp point angle		↓					↑		↓								
	• Excessive cutting speed (Considered tool grade)	↑				●	↓	⊙					↑					
Fracture	Breakage on contact	• Poor surface finish			●	↓											●	
		• Insufficient machine rigidity												↑				●
		• Improper cutting condition	↑	↓														
	Breakage at hole bottom	• Crooked hole	↑						↑				●			↓	●	
		• Chip clogging		↓	●							↑						

↑: Increase ↓: Decrease ●: use ⊙: Correct use



 Hole size for threading

● Metric coarse screw threads

Specification	Hole diameter
M1 X 0.25	0.75
M1.1 X 0.25	0.85
M1.2 X 0.25	0.95
M1.4 X 0.3	1.1
M1.6 X 0.35	1.25
M1.7 X 0.35	1.35
M1.8 X 0.35	1.45
M2 X 0.4	1.6
M2.2 X 0.45	1.75
M2.3 X 0.4	1.9
M2.5 X 0.45	2.1
M2.6 X 0.45	2.2
M3 X 0.6	2.4
M3 X 0.5	2.5
M3.5 X 0.6	2.9
M4 X 0.75	3.25
M4 X 0.7	3.3
M4.5 X 0.75	3.8
M5 X 0.9	4.1
M5 X 0.8	4.2
M5.5 X 0.9	4.6
M6 X 1	5
M7 X 1	6
M8 X 1.25	6.8
M9 X 1.25	7.8
M10 X 1.5	8.5
M11 X 1.5	9.5
M12 X 1.75	10.3
M14 X 2	12
M16 X 2	14
M18 X 2.5	15.5
M20 X 2.5	17.5
M22 X 2.5	19.5
M24 X 3	21
M27 X 3	24
M30 X 3.5	26.5
M33 X 3.5	29.5
M36 X 4	32
M39 X 4	35
M42 X 4.5	37.5
M45 X 4.5	40.5
M48 X 5	43

● Metric coarse screw threads

Specification	Hole diameter
M2.5 X 0.35	2.2
M3 X 0.35	2.7
M3.5 X 0.35	3.2
M4 X 0.5	3.5
M4.5 X 0.5	4
M5 X 0.5	4.5
M5.5 X 0.5	5
M6 X 0.75	5.3
M7 X 0.75	6.3
M8 X 1	7
M8 X 0.75	7.3
M9 X 1	8
M9 X 0.75	8.3
M10 X 1.25	8.8
M10 X 1	9
M10 X 0.75	9.3
M11 X 1	10
M11 X 0.75	10.3
M12 X 1.5	10.5
M12 X 1.25	10.8
M12 X 1	11
M14 X 1.5	12.5
M14 X 1	13
M15 X 1.5	13.5
M15 X 1	14
M16 X 1.5	14.5
M16 X 1	15
M17 X 1.5	15.5
M17 X 1	16
M18 X 2	16
M18 X 1.5	16.5
M18 X 1	17
M20 X 2	18
M20 X 1.5	18.5
M20 X 1	19
M22 X 2	20
M22 X 1.5	20.5
M22 X 1	21
M24 X 2	22
M24 X 1.5	22.5
M24 X 1	23
M25 X 2	23
M25 X 1.5	23.5
M25 X 1	24
M26 X 1.5	24.5
M27 X 2	25

⚠ Cautions

● Selection of drill chuck

- Collect chuck is favorable Because it has strong grip power (General drill-chuck and Keyless chuck don't have enough grip power.)

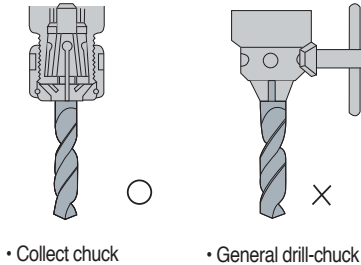

• Collect chuck

• General drill-chuck

● Coolant supply

- Supply enough coolant around hole entrance
- Standard cutting oil pressure: 3~5 kg/cm², Flux: 2~5 l/min

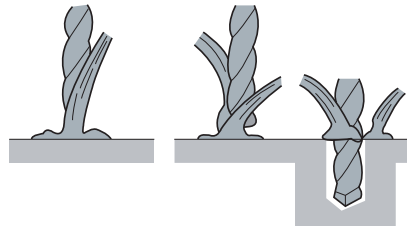

• Supply much coolant at hole entrance

● Mounting drill

- When mounting drill Periphery chattering should be within 0.02 mm
- Flute should not be clamped

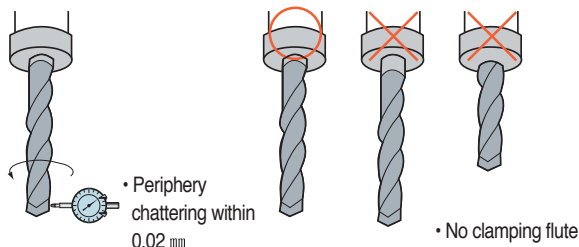

• Periphery chattering within 0.02 mm

• No clamping flute

● How to clamp workpiece

- At high performance drilling High thrust, torque and horizontal cutting force work at the same time so that workpiece should be clamped strongly to prevent chattering

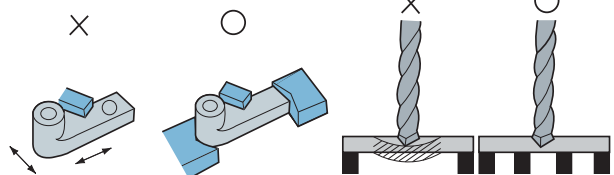

• Uniform and strong clamping is needed (Right and left, up and down)

• Strong clamping is needed because bending causes chipping

⚠ Notice

- 1) For better drill's life, small damage and wear are favorable to be regrinding
- 2) Damage and wear size should be within 1.5 mm for regrinding
- 3) If drill has crack, regrinding is impossible
- 4) Ordering for regrinding is acceptable or purchase regrinding machine

⚠ Regrinding procedures

● Regrinding method (Mach Drill)

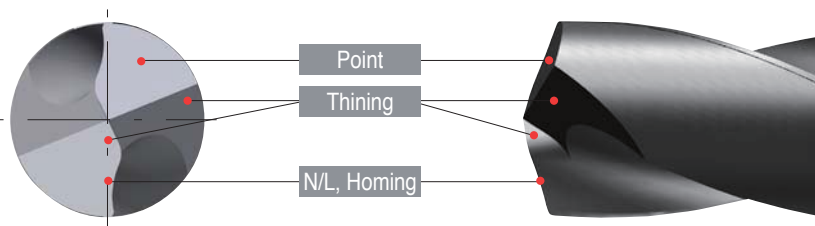

1) Preparation Determination of regrinding areas

- Check the cutting edge for damage and wear If large fracture is found, remove it by rough grinding



2) Grinding operation Drills setting

- Drill is clamped to collet chuck Chattering is kept within 0.02 mm

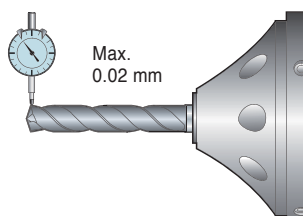

3) Grinding operation-Grinding point

- Check damage and wear at the point and remove it completely
- The difference of the lip height is kept within 0.02 mm

Point angle (a): 140°
Point relief angle (b): 8°~15°

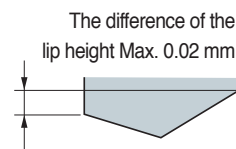
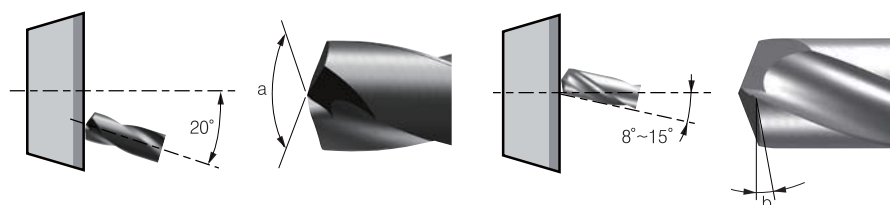
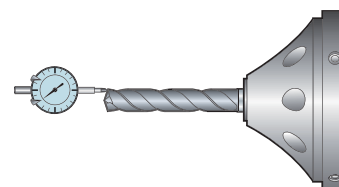

4) Grinding operation-Thinning grinding

- Considering N/L width Cutting edge length from the center of drill axis should be 0.03~0.08mm for balancing
- Set the wheel to tilt drill axis by 34°~40°.

Thinning angle (a): 155°~160° Thinning open angle (b): 100°~105°
Thinning relief angle (c): 34°~40°

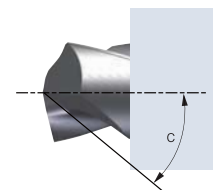
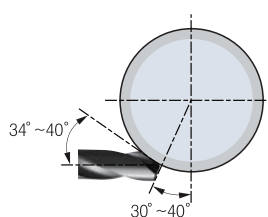
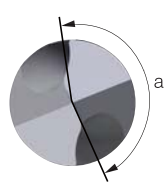
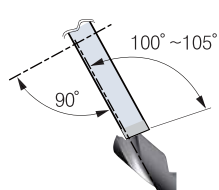

5) Grinding-N/L grinding and honing

- Using diamond chisel Grinds the width flat along point cutting edge
- After negaland operation Finishes with brush or handstone

N/L width (a): 0.05mm~0.16mm/N/L angle (b): 24°~26°

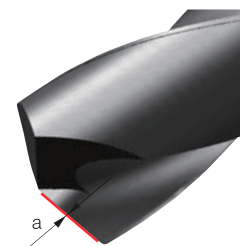
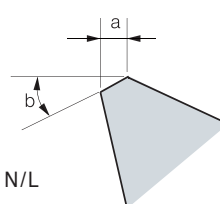

● TIP

- Making point
 - Without center drill, the point width should be below 0.10 mm
- Recommended grinding condition
 - Diamond wheel: 240~400 mesh
 - Diamond chisel: 400~600 mesh
 - Diamond hand stone: 800~1500 mesh

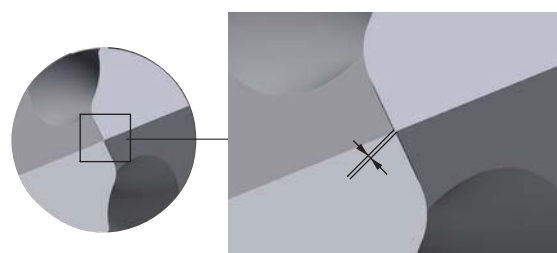

➤ Hexagonal socket bolt (clamping screw) size

● Counter boring and size of bolt hole for hexagonal socket bolt

ISO (d)	M3	M4	M5	M6	M8	M10	M12	M14	M16	M18	M20	M22	M24	M27	M30
Ød _i	3	4	5	6	8	10	12	14	16	18	20	22	24	27	30
Ød'	3.4	4.5	5.5	6.5	8.5	11	14	16	18	20	22	24	26	30	33
ØD	5.5	7	8.5	10	13	16	18	21	24	27	30	33	36	40	45
ØD'	5	8	9.5	11	14	17.5	20	23	26	29	32	35	39	43	48
H	3	4	5	6	8	10	12	14	16	18	20	22	24	27	30
H'	2.7	3.6	4.6	5.5	7.4	9.2	11.0	12.8	14.5	16.5	18.5	20.5	22.5	25	28
H''	3.3	4.4	5.4	6.5	8.6	10.8	13.0	15.2	17.5	19.5	21.5	23.5	25.5	29	32

