



**INDIAN TOOL
MANUFACTURERS**
(A DIVISION OF ZENITH BIRLA INDIA LTD)

REGISTERED OFFICE

Dalamal House, 1st Floor,
206, J. Bajaj Road, Nariman Point,
Mumbai - 400 021.
Telephone : (022) 22821173 / 22821174
Fax : (022) 22047835
E-mail : zenith@bom3.vsnl.net.in

NASIK UNIT

62/63, MIDC Industrial Area,
Satpur, Nasik - 422 007
Telephone : (0253) - 2350320 / 21 / 22
Telegram : ITOOLS' Nasik
Email : itm@nashiknet.com

AURANGABAD UNIT

B-15/3, MIDC Industrial Area,
Waluj, Aurangabad - 431 133.
Telephone : waluj 0240 -2564056 / 57 / 386
Fax : (0240) - 2554673
E-mail : itmagb_agd@sancharnet.in



RWTUV

www.indiantool.com



PRODUCT CATALOGUE



**INDIAN TOOL
MANUFACTURERS**
(A DIVISION OF ZENITH BIRLA INDIA LTD)

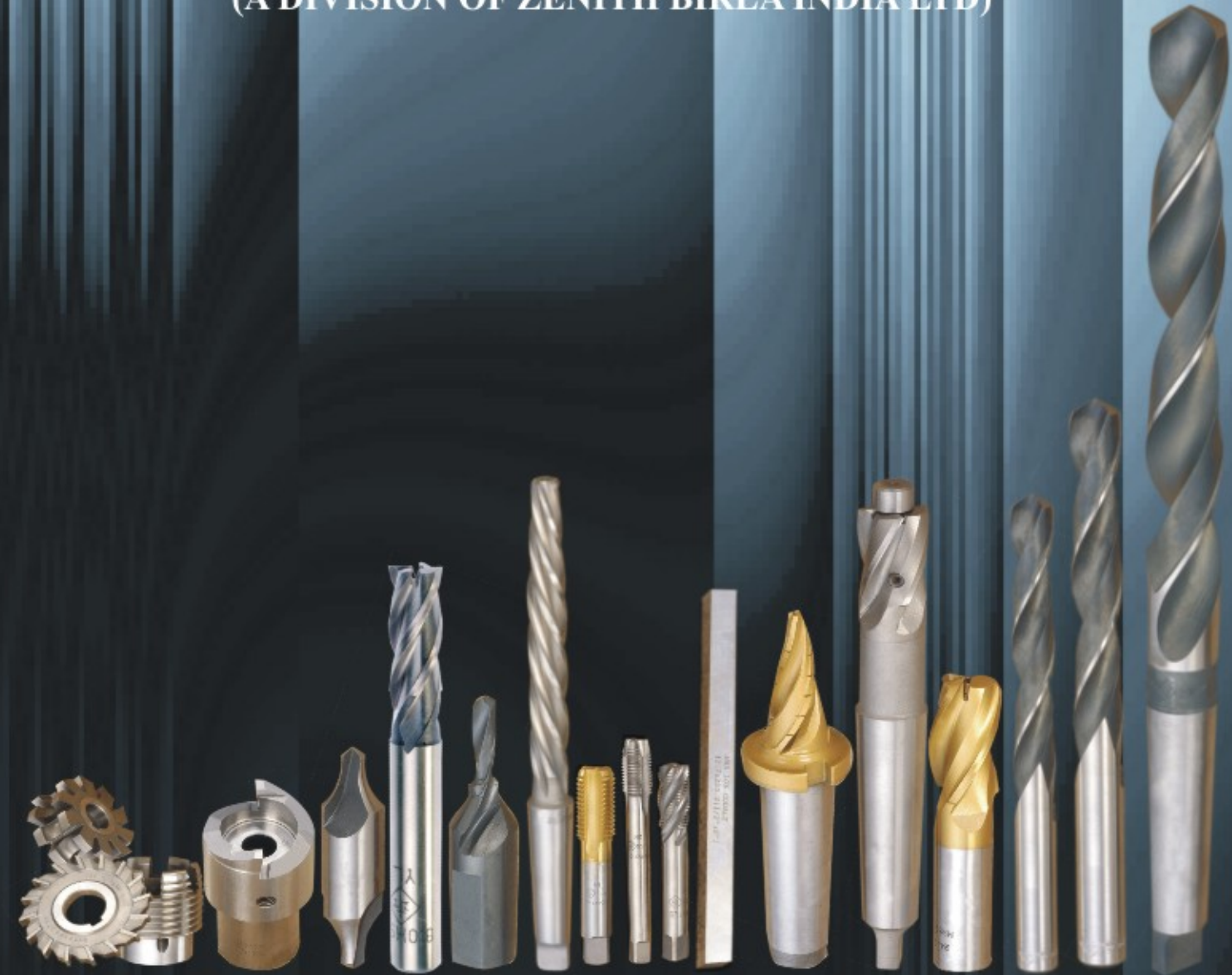

PRODUCT CATALOGUE



UNIT NO. 1 NASIK PLANT

UNIT NO. 2 AURANGABAD PLANT



PLANT FACILITY



HARDNESS TESTING



PRECISION THREAD GRINDING MACHINE



THREAD PROFILE CHECKING



HIGH PRODUCTIVITY AUTOMATIC FLUTE GRINDING MACHINE



HIGH PRODUCTIVITY AUTOMATIC POINT GRINDING MACHINE



METALLURGICAL MICROSCOPE

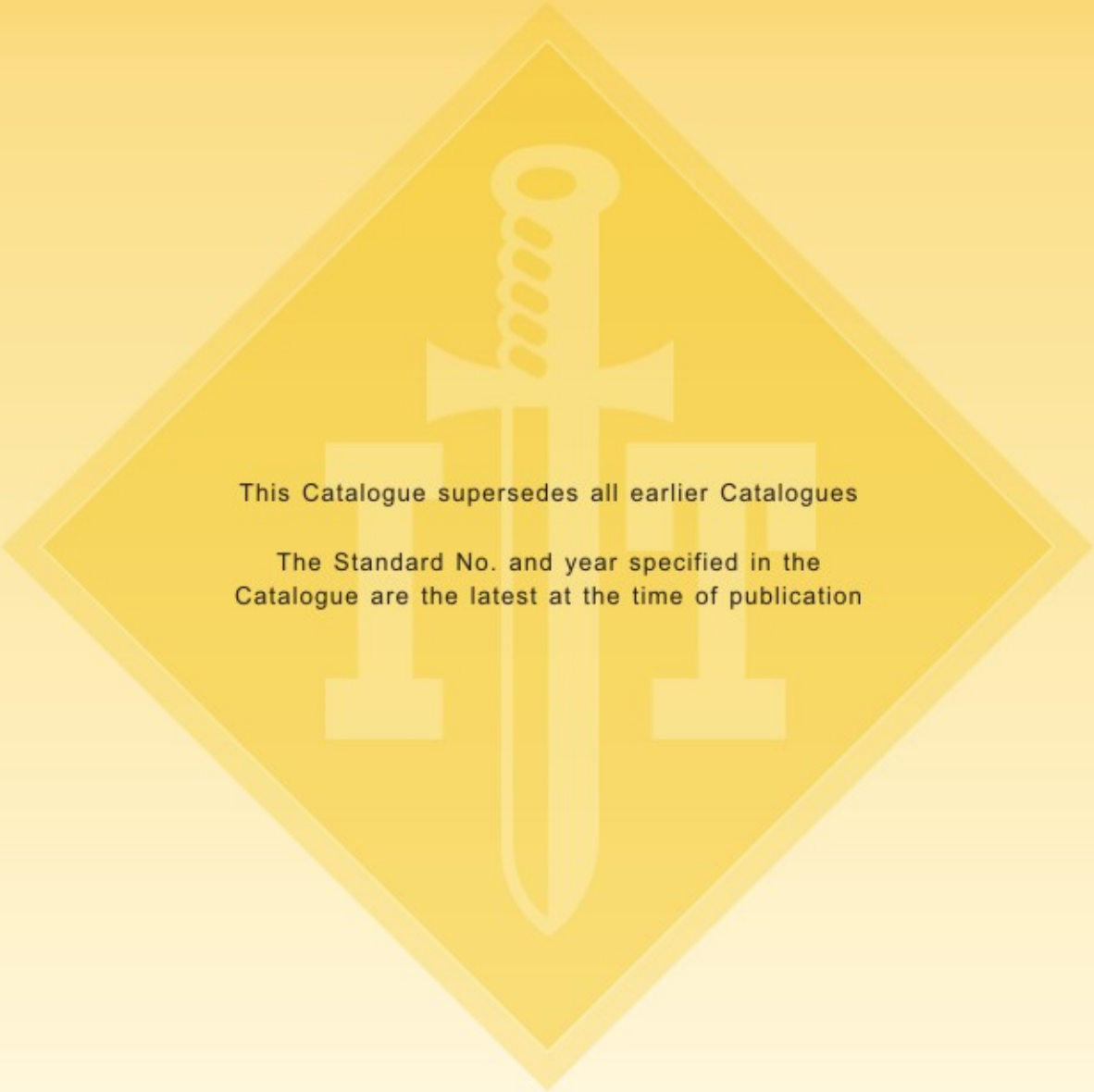

This Catalogue supersedes all earlier Catalogues

The Standard No. and year specified in the
Catalogue are the latest at the time of publication



All rights reserved by Publisher, No part of this catalogue may be reproduced or transmitted in any form or by any means without the written permission of the publisher

Published by :

INDIAN TOOL
MANUFACTURERS
(A DIVISION OF ZENITH BIRLA INDIA LTD)

Printed in the year 2006

All efforts are made to ensure the correctness of the information in the catalogue of products manufactured / supplied by Publisher.

However, Publisher does not accept any liability for any error or omission in the catalogue.



Indian Tool Manufacturers (ITM) - A division of Zenith Birla (India) Ltd, belonging to the Yash Birla Group, pioneered in the year 1937, the manufacture and supply of High Speed Steel Cutting Tools in India. Intensive research and development work has been an integral part of ITM's total operation on a continuous basis.

ITM products popularly known as "Dagger Brand" made from the finest High Speed Steel and conforming to stringent international standards are now exported to the European and American Markets apart from being sold throughout India through an extensive Distribution Network.

An extensive range of High Speed Steel Cutting Tools in various grades (M2, M35, M42 & T42) and a catalogue product range of various types of Drills, an assortment of Milling Cutters, Reamers, Taps and Tool Bits are manufactured in ITM's two well equipped units in Maharashtra having ISO 9001:2000 certification. The first plant in Nasik where mainly special tools are manufactured as per customer requirement and the second plant at Aurangabad, manufacturing standard catalogue items.

ITM have established a wide marketing network of branches/resident representatives/Distributors/Dealers at Ahmedabad, Bangalore, Baroda, Bhopal, Mumbai, Kolkata, Cochin, Delhi, Faridabad, Jamshedpur, Kanpur, Ludhiana, Chennai, Pune and Secunderabad.





Indian Tool Manufacturers (ITM) - A division of Zenith Birla (India) Ltd, belonging to the Yash Birla Group, pioneered in the year 1937, the manufacture and supply of High Speed Steel Cutting Tools in India. Intensive research and development work has been an integral part of ITM's total operation on a continuous basis.

ITM products popularly known as "Dagger Brand" made from the finest High Speed Steel and conforming to stringent international standards are now exported to the European and American Markets apart from being sold throughout India through an extensive Distribution Network.

An extensive range of High Speed Steel Cutting Tools in various grades (M2, M35, M42 & T42) and a catalogue product range of various types of Drills, an assortment of Milling Cutters, Reamers, Taps and Tool Bits are manufactured in ITM's two well equipped units in Maharashtra having ISO 9001:2000 certification. The first plant in Nasik where mainly special tools are manufactured as per customer requirement and the second plant at Aurangabad, manufacturing standard catalogue items.

ITM have established a wide marketing network of branches/resident representatives/Distributors/Dealers at Ahmedabad, Bangalore, Baroda, Bhopal, Mumbai, Kolkata, Cochin, Delhi, Faridabad, Jamshedpur, Kanpur, Ludhiana, Chennai, Pune and Secunderabad.





INDIAN TOOL MANUFACTURERS

(A DIVISION OF ZENITH BIRLA INDIA LTD)

BRANCHES

BANGALORE

TBH Plaza, 2nd Floor,
No. 34, SJP Road,
Bangalore - 560 002.
Tel : 080 - 2128347
Fax : 080 - 2128355
E-mail : itmblr@dataone.in

CHENNAI

157, Linghi Chetty Street,
Chennai - 600 001.
Tel. (O) : 044-25342636 /
Fax : 044-25340163
Telegram : 'Bestools 'Madras'
E-mail : itm_chen@dataone.in

DELHI

2/11, Ansari Road,
Darya Ganj,
New Delhi - 110 002
Tel. (O) : 011-23276809 / 23278531
Fax : 011-23263402
Telegram : 'DAGERTOOLS'
E-mail : itmdel@del2.vsnl.net.in

KOLKATA

'NICCO' House, 4th Floor,
2 Hare Street,
Kolkata - 700 001
Tel. (O) : 033-22485191
Fax : 033-22486449
Telegram : 'DAGERTOOLS' Calcutta
E-mail : itmcal@glascl01.vsnl.net.in

LUDHIANA

Jassal House
G.T. Road,
Ludhiana - 141 008
Tel. (O) : 0161-2722542, 2722535
Fax : 0161-2722542
Telegram : 'TOOLS' Ludhiana
E-mail : zenith@jla.vsnl.net.in
zenithid@sify.com

MUMBAI (THANE)

First Pokharan Road,
Thane (W) - 400 606.
MAHARASHTRA (INDIA)
Tel. : 022 - 25882551 (Board)
Fax : 022 - 25882555 / 25882554
E-mail : itmth@bom7.vsnl.net.in

SECUNDRABAD

5-1-535, Hill Street,
2nd Floor, Ranigunj,
Secundrabad - 500 003
Tel. (O) : 040-27713177
Fax : 040-27718093
Telegram : 'TOOLS' SEC-BAD
E-mail : hyd1_itsec@sancharnet.in

DISTRIBUTORS

M/S. BIRLA INTERNATIONAL PVT. LTD.

MUMBAI

308/312 Atlanta estate
Goregaon Mulund link Road,
Hanuman Takri Bit Bhatti,
Goregaon (E), Mumbai - 400 063.
Tel : 28713177 / 358 / 359
E-mail : birlaint@bom5.vsnl.net.in

AHMEDABAD

104, New Cloth Market,
Ahmedabad - 380 002.
Tel. : 079-22160673 / 2212 3277
Fax : 079-22124642
E-mail : birlaintadi@sancharnet.in

C & F AGENTS

LUCKNOW

MPS Marketing (P) Ltd.
Regd. Off. : 27, Sarai Durvijaiganj,
Lucknow - 226 018
Tel. : 683391 / 683392
Fax : 0522-683393
E-mail : birlaint@ad1.vsnl.net.in
Sales Off.: Fatehganj, Aminabad Road,
Lucknow - 226 018
Tel : 682312 / 682314

RESIDENCE REPRESENTATIVE

PUNE

Indian Tool Mfrs.
Flat No.9, Shriraj Prathmesh Apartment
Near Mandal, Chinchwadgaon
Pune - 411 033
Tel. (o) : 020-27 456083
Fax : 020-27456083
E-mail : ithpune@eth.net

INDEX

Product	DESCRIPTION	Specification	Pg. No.
	Parallel Shank Twist Drills (Stub Series)	IS 5100 : 2002 ISO 235 : 1980 BS 328 Part 1 : 1993 DIN 1897 : 1984	1-8
	Parallel Shank Twist Drills (Jobber Series)	IS 5101 : 2002 ISO 235 : 1980 BS 328 Part 1 : 1993 DIN 338 : 1984	9-14
	Parallel Shank Twist Drills (Long Series)	IS 5102 : 2002 ISO 494 : 1975 BS 328 Part 1 : 1993 DIN 340 : 1978	15-21
	Parallel Shank Twist Drills (Extra Long Series)	IS 7823 : 2005 ISO 3292 : 1995	22-25
	Taper Shank Twist Drills (With Standard Shank)	IS 5103 : 2002 ISO 2351 : 1980 BS 328 Part 1 : 1993 DIN 345 : 1978	26-35
	Taper Shank Twist Drills (With Oversize Shank)	IS 5104 : 2002 ISO 2351 : 1980 BS 328 Part 1 : 1993	36-40
	Taper Shank Twist Drills (Long Series)	IS 8305 : 2002 DIN 341 : 1978	41-47
	Taper Shank Twist Drills (Extra Long Series)	IS 7822 : 2005 ISO 3291 : 1995	48-53
	Taper Shank Core Drills	IS 5366 : 2002 ISO 7079 : 1981 BS 328 Part 3 : 1990 DIN 343 : 1981	54-58
	Shell Core Drills	IS 7772 : 2002 ISO 3314 : 1975 BS 328 Part 4 : 1990	59-60
	Centre Drill Type 'A'	IS 6708 : 2002 ISO 866 : 1975 DIN 333 : 1986	61
	Centre Drill Type 'B'	IS 6709 : 2002 ISO 2540 : 1972 DIN 333 : 1986	62
	Centre Drill Type 'R'	IS 6710 : 2002 ISO 2541 : 1972 DIN 333 : 1986	63
	Centre Drill B.S.	BS 328 Part 2 : 1990	64
	Parallel Shank Subland Twist Drill	IS 12691 : 1999 ISO 3439 : 1975 DIN 8378 : 1981	65
	Taper Shank Subland Twist Drill	IS 12687 : 1999 ISO 3438 : 1975 DIN 8379 : 1981	66
	Taper Shank Twist Drills For Taper Pin Holes	IS 5364 : 2002	67
	Masonry Drills-Carbide Tipped	Specifications conforms to: ITM Standard	68
	Technical Section		69-75



TWIST DRILLS

Experttoolings.com





Elements of a Twist Drill and Related Terms

Twist drill with parallel shank

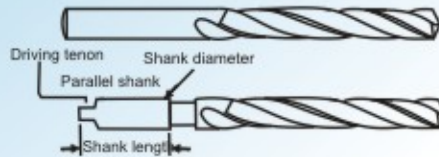

Twist drill with Taper shank

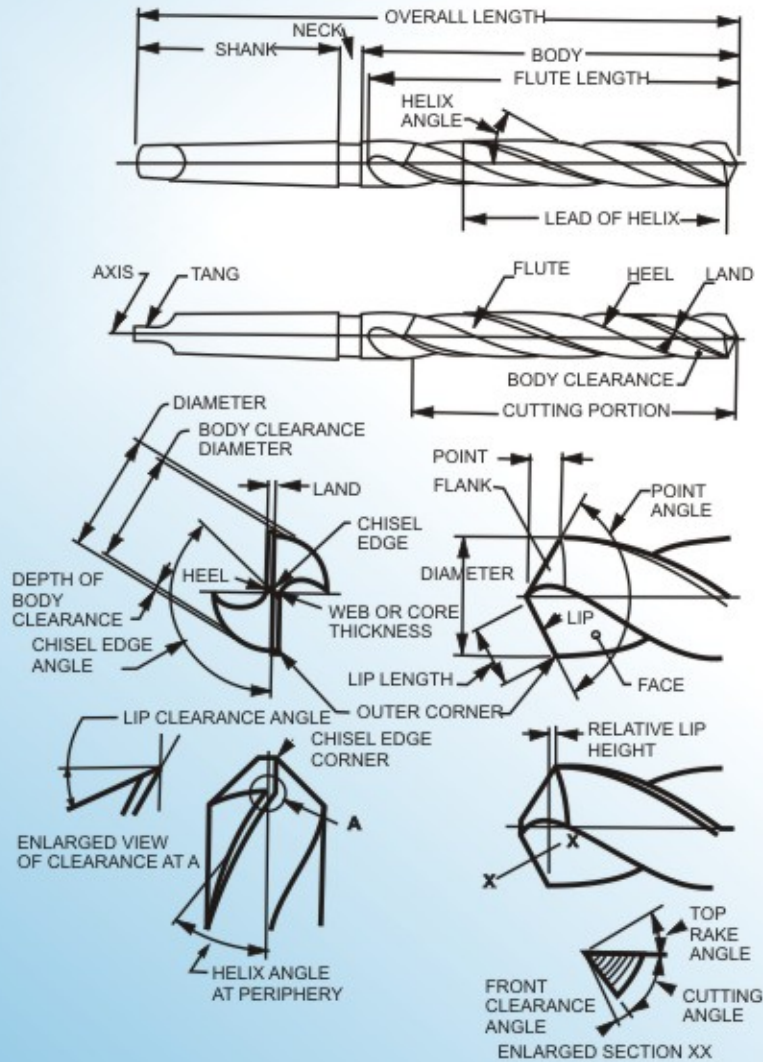

**High Speed Steel
PARALLEL SHANK TWIST DRILLS
(Stub Series)**



Size (h8)			Flute Length	Overall Length
mm	inch	No		
1.00			6	26
1.02		60	6	26
1.04		59	6	26
1.07		58	7	28
1.09		57	7	28
1.10			7	28
1.18		56	7	28
1.19	3/64		8	30
1.20			8	30
1.30			8	30
1.32		55	8	30
1.40		54	9	32
1.50			9	32
1.51		53	10	34
1.59	1/16		10	34
1.60			10	34
1.61		52	10	34
1.70		51	10	34
1.78		50	11	36
1.80			11	36
1.85		49	11	36
1.90			11	36
1.93		48	12	38
1.98	5/64		12	38
1.99		47	12	38
2.00			12	38
2.06		46	12	38
2.08		45	12	38
2.10			12	38
2.18		44	13	40
2.20			13	40
2.26		43	13	40
2.30			13	40
2.37		42	14	43
2.38	3/32		14	43
2.40			14	43
2.44		41	14	43
2.49		40	14	43
2.50			14	43
2.53		39	14	43
2.58		38	14	43
2.60			14	43
2.64		37	14	43
2.70			16	46
2.71		36	16	46
2.78	7/64		16	46
2.79		35	16	46

Figures mentioned in Red are for reference only
Ground flutes upto 13 mm & milled flutes above 13 mm

Range of Application:

For use mainly with portable drilling machines for drilling in sheet metal.



TWIST DRILLS

Specifications conform to
IS 5100 : 2002
ISO 235 : 1980
BS 328 Part 1 : 1993
DIN 1897 : 1984



TWIST DRILLS



Specifications conform to
 IS 5100 : 2002
 ISO 235 1980
 BS 328 Part 1 : 1993
 DIN 1897 : 1984

High Speed Steel PARALLEL SHANK TWIST DRILLS (Stub Series)

Size (h8)		No	Flute Length	Overall Length
mm	inch			
2.80			16	46
2.82		34	16	46
2.87		33	16	46
2.90			16	46
2.95		32	16	46
3.00			16	46
3.05		31	18	49
3.10			18	49
3.17	1/8		18	49
3.20			18	49
3.26		30	18	49
3.30			18	49
3.40			20	52
3.45		29	20	52
3.50			20	52
3.57	9/64	28	20	52
3.60			20	52
3.66		27	20	52
3.70			20	52
3.73		26	20	52
3.80		25	22	55
3.86		24	22	55
3.90			22	55
3.91		23	22	55
3.97	5/32		22	55
3.99		22	22	55
4.00			22	55
4.04		21	22	55
4.09		20	22	55
4.10			22	55
4.20			22	55
4.22		19	22	55
4.30		18	24	58
4.37	11/64		24	58
4.39		17	24	58
4.40			24	58
4.50		16	24	58
4.57		15	24	58
4.60			24	58
4.62		14	24	58
4.70		13	24	58
4.76	3/16		26	62
4.80		12	26	62
4.85		11	26	62
4.90			26	62
4.91		10	26	62
4.98		9	26	62

Figures mentioned in Red are for reference only
 Ground flutes upto 13 mm & milled flutes above 13 mm

Range of Application:

For use mainly with portable drilling machines for drilling in sheet metal.

**High Speed Steel
PARALLEL SHANK TWIST DRILLS
(Stub Series)**



Size (h8)		No./Letter	Flute Length	Overall Length
mm	inch			
5.00			26	62
5.05		8	26	62
5.10			26	62
5.11		7	26	62
5.16	13/64		26	62
5.18		6	26	62
5.20			26	62
5.22		5	26	62
5.30			26	62
5.31		4	28	66
5.40			28	66
5.41		3	28	66
5.50			28	66
5.56	7/32		28	66
5.60			28	66
5.61		2	28	66
5.70			28	66
5.79		1	28	66
5.80			28	66
5.90			28	66
5.94		A	28	66
5.95	15/64		28	66
6.00			28	66
6.05		B	31	70
6.10			31	70
6.15		C	31	70
6.20			31	70
6.25		D	31	70
6.30			31	70
6.35	1/4	E	31	70
6.40			31	70
6.50			31	70
6.53		F	31	70
6.60			31	70
6.63		G	31	70
6.70			31	70
6.75	17/64		34	74
6.76		H	34	74
6.80			34	74
6.90			34	74
6.91		I	34	74
7.00			34	74
7.04		J	34	74
7.10			34	74
7.14	9/32	K	34	74
7.20			34	74
7.30			34	74
7.37		L	34	74
7.40			34	74
7.49		M	34	74
7.50			34	74

Figures mentioned in Red are for reference only
Ground flutes upto 13 mm & milled flutes above 13 mm

Range of Application:

For use mainly with portable drilling machines for drilling in sheet metal.



TWIST DRILLS

Specifications conform to
IS 5100 : 2002
ISO 235 : 1980
BS 328 Part 1 : 1993
DIN 1897 : 1984



TWIST DRILLS



Specifications conform to
 IS 5100 : 2002
 ISO 235 1980
 BS 328 Part 1 : 1993
 DIN 1897 : 1984

High Speed Steel PARALLEL SHANK TWIST DRILLS (Stub Series)

Size (h8)		Letter	Flute Length	Overall Length
mm	inch			
7.54	19/64		37	79
7.60			37	79
7.67		N	37	79
7.70			37	79
7.80			37	79
7.90			37	79
7.94	5/16		37	79
8.00			37	79
8.03		O	37	79
8.10			37	79
8.20		P	37	79
8.30			37	79
8.33	21/64		37	79
8.40			37	79
8.43		Q	37	79
8.50			37	79
8.60			40	84
8.61		R	40	84
8.70			40	84
8.73	11/32		40	84
8.80			40	84
8.84		S	40	84
8.90			40	84
9.00			40	84
9.09		T	40	84
9.10			40	84
9.13	23/64		40	84
9.20			40	84
9.30			40	84
9.35		U	40	84
9.40			40	84
9.50			40	84
9.52	3/8		43	89
9.58		V	43	89
9.60			43	89
9.70			43	89
9.80		W	43	89
9.90			43	89
9.92	25/64		43	89
10.00			43	89
10.08		X	43	89
10.10			43	89
10.20			43	89
10.26		Y	43	89
10.30			43	89
10.32	13/32		43	89
10.40			43	89
10.49		Z	43	89
10.50			43	89
10.60			43	89

Figures mentioned in Red are for reference only
 Ground flutes upto 13 mm & milled flutes above 13 mm

Range of Application:

For use mainly with portable drilling machines for drilling in sheet metal.

**High Speed Steel
PARALLEL SHANK TWIST DRILLS
(Stub Series)**



Size (h8)		Flute Length	Overall Length
mm	inch		
10.72	27/64	47	95
10.80		47	95
10.90		47	95
11.00		47	95
11.10		47	95
11.11	7/16	47	95
11.20		47	95
11.30		47	95
11.40		47	95
11.50		47	95
11.51	29/64	47	95
11.60		47	95
11.70		47	95
11.80		47	95
11.90		51	102
11.91	15/32	51	102
12.00		51	102
12.10		51	102
12.20		51	102
12.30	31/64	51	102
12.40		51	102
12.50		51	102
12.60		51	102
12.70	1/2	51	102
12.80		51	102
12.90		51	102
13.00		51	102
13.10		51	102
13.20		51	102
13.30		54	107
13.40		54	107
13.49	17/32	54	107
13.50		54	107
13.60		54	107
13.70		54	107
13.80		54	107
13.89		54	107
13.90	35/64	54	107
14.00		54	107
14.25		56	111
14.29	9/16	56	111
14.50		56	111
14.68	37/64	56	111
14.75		56	111
15.00		56	111
15.08	19/32	58	115
15.25		58	115
15.48	39/64	58	115
15.50		58	115

Figures mentioned in Red are for reference only
Ground flutes upto 13 mm & milled flutes above 13 mm

Range of Application:

For use mainly with portable drilling machines for drilling in sheet metal.



TWIST DRILLS

Specifications conform to
IS 5100 : 2002
ISO 235 : 1980
BS 328 Part 1 : 1993
DIN 1897 : 1984



TWIST DRILLS



Specifications conform to
 IS 5100 : 2002
 ISO 235 1980
 BS 328 Part 1 : 1993
 DIN 1897 : 1984

High Speed Steel PARALLEL SHANK TWIST DRILLS (Stub Series)

Size (h8)		Flute Length	Overall Length
mm	inch		
15.75		58	115
15.87	5/8	58	115
16.00		58	115
16.25		60	119
16.27	41/64	60	119
16.50		60	119
16.67	21/32	60	119
16.75		60	119
17.00		60	119
17.07	43/64	62	123
17.25		62	123
17.46	11/16	62	123
17.50		62	123
17.75		62	123
17.86	45/64	62	123
18.00		62	123
18.25		64	127
18.26	23/32	64	127
18.50		64	127
18.65	47/64	64	127
18.75		64	127
19.00		64	127
19.05	3/4	66	131
19.25		66	131
19.45	49/64	66	131
19.50		66	131
19.75		66	131
19.84	25/32	66	131
20.00		66	131
20.24	51/64	68	136
20.25		68	136
20.50		68	136
20.64	13/16	68	136
20.75		68	136
21.00		68	136
21.03	53/64	68	136
21.25		70	141
21.43	27/32	70	141
21.50		70	141
21.75		70	141
21.83	55/64	70	141
22.00		70	141
22.22	7/8	70	141
22.25		70	141
22.50		72	146
22.62	57/64	72	146
22.75		72	146
23.00		72	146

Figures mentioned in Red are for reference only
 Ground flutes upto 13 mm & milled flutes above 13 mm

Range of Application:

For use mainly with portable drilling machines for drilling in sheet metal.

**High Speed Steel
PARALLEL SHANK TWIST DRILLS
(Stub Series)**



Size (h8)		Flute Length	Overall Length
mm	inch		
23.02	29/32	72	146
23.25		72	146
23.42	59/64	72	146
23.50		72	146
23.75		75	151
23.81	15/16	75	151
24.00		75	151
24.21	61/64	75	151
24.25		75	151
24.50		75	151
24.61	31/32	75	151
24.75		75	151
25.00	63/64	75	151
25.25		78	156
25.40	1	78	156
25.50		78	156
25.75		78	156
26.00		78	156
26.19	1.1/32	78	156
26.25		78	156
26.50		78	156
26.75		81	162
26.99	1.1/16	81	162
27.00		81	162
27.25		81	162
27.50		81	162
27.75		81	162
27.78	1.3/32	81	162
28.00		81	162
28.25		84	168
28.50		84	168
28.58	1.1/8	84	168
28.75		84	168
29.00		84	168
29.25		84	168
29.37	1.5/32	84	168
29.50		84	168
29.75		84	168
30.00		84	168
30.16	1.3/16	87	174
30.25		87	174
30.50		87	174
30.75		87	174
30.96	1.7/32	87	174
31.00		87	174
31.25		87	174
31.50		87	174
31.75	1.1/4	90	180

Figures mentioned in Red are for reference only
Ground flutes upto 13 mm & milled flutes above 13 mm

Range of Application:

For use mainly with portable drilling machines for drilling in sheet metal.



TWIST DRILLS

Specifications conform to
IS 5100 : 2002
ISO 235 : 1980
BS 328 Part 1 : 1993
DIN 1897 : 1984



TWIST DRILLS



Specifications conform to
 IS 5100 : 2002
 ISO 235 1980
 BS 328 Part 1 : 1993
 DIN 1897 : 1984

High Speed Steel PARALLEL SHANK TWIST DRILLS (Stub Series)

Size (h8)		Flute Length	Overall Length
mm	inch		
32.00		90	180
32.50		90	180
32.54	1.9/32	90	180
33.00		90	180
33.34	1.5/16	90	180
33.50		90	180
34.00		93	186
34.13	1.11/32	93	186
34.50		93	186
34.92	1.3/8	93	186
35.00		93	186
35.50		93	186
35.72	1.13/32	96	193
36.00		96	193
36.50		96	193
36.51	1.7/16	96	193
37.00		96	193
37.31	1.15/32	96	193
37.50		96	193
38.00		100	200
38.10	1.1/2	100	200
38.50		100	200
38.89		100	200
39.00		100	200
39.50		100	200
39.69		100	200
40.00		100	200

Figures mentioned in Red are for reference only
 Ground flutes upto 13 mm & milled flutes above 13 mm

Range of Application:
 For use mainly with portable drilling machines for drilling in sheet metal.

**High Speed Steel
PARALLEL SHANK TWIST DRILLS
(Jobber Series)**



Size (h8)		No.	Flute Length	Overall Length
mm	inch			
1.00			12	34
1.02		60	12	34
1.04		59	12	34
1.07		58	14	36
1.09		57	14	36
1.10			14	36
1.18		56	14	36
1.19	3/64		16	38
1.20			16	38
1.30			16	38
1.32		55	16	38
1.40		54	18	40
1.50			18	40
1.51		53	20	43
1.59	1/16		20	43
1.60			20	43
1.61		52	20	43
1.70		51	20	43
1.78		50	22	46
1.80			22	46
1.85		49	22	46
1.90			22	46
1.93		48	24	49
1.98	5/64		24	49
1.99		47	24	49
2.00			24	49
2.06		46	24	49
2.08		45	24	49
2.10			24	49
2.18		44	27	53
2.20			27	53
2.26		43	27	53
2.30			27	53
2.37		42	30	57
2.38	3/32		30	57
2.40			30	57
2.44		41	30	57
2.49		40	30	57
2.50			30	57
2.53		39	30	57
2.58		38	30	57
2.60			30	57
2.64		37	30	57
2.7			33	61
2.71		36	33	61

Figures mentioned in Red are for reference only
Ground flutes upto 13 mm & milled flutes above 13 mm

Range of Application:
For general purpose use



TWIST DRILLS

Specifications conform to
IS 5101 : 2002
ISO 235 : 1980
BS 328 Part 1 : 1993
DIN 338 : 1984



TWIST DRILLS



Specifications conform to
 IS 5101 : 2002
 ISO 235 1980
 BS 328 Part 1 : 1993
 DIN 338 : 1984

High Speed Steel PARALLEL SHANK TWIST DRILLS (Jobber Series)

Size (h8)			Flute Length	Overall Length
mm	inch	No		
2.78	7/64		33	61
2.79		35	33	61
2.80			33	61
2.82		34	33	61
2.87		33	33	61
2.90			33	61
2.95		32	33	61
3.00			33	61
3.05		31	36	65
3.10			36	65
3.17	1/8		36	65
3.20			36	65
3.26		30	36	65
3.30			36	65
3.40			39	70
3.45		29	39	70
3.50			39	70
3.57	9/64	28	39	70
3.60			39	70
3.66		27	39	70
3.70			39	70
3.73		26	39	70
3.80		25	43	75
3.86		24	43	75
3.90			43	75
3.91		23	43	75
3.97	5/32		43	75
3.99		22	43	75
4.00			43	75
4.04		21	43	75
4.09		20	43	75
4.10			43	75
4.20			43	75
4.22		19	43	75
4.30		18	47	80
4.37	11/64		47	80
4.39		17	47	80
4.40			47	80
4.50		16	47	80
4.57		15	47	80
4.60			47	80
4.62		14	47	80
4.70		13	47	80
4.76	3/16		52	86
4.80		12	52	86
4.85		11	52	86

Figures mentioned in Red are for reference only
 Ground flutes upto 13 mm & milled flutes above 13 mm

Range of Application:
 For general purpose use

**High Speed Steel
PARALLEL SHANK TWIST DRILLS
(Jobber Series)**



Size (h8)			Flute Length	Overall Length
mm	inch	No./Letter		
4.90			52	86
4.91		10	52	86
4.98		9	52	86
5.00			52	86
5.05		8	52	86
5.10			52	86
5.11		7	52	86
5.16	13/64		52	86
5.18		6	52	86
5.20			52	86
5.22		5	52	86
5.30			52	86
5.31		4	57	93
5.40			57	93
5.41		3	57	93
5.50			57	93
5.56	7/32		57	93
5.60			57	93
5.61		2	57	93
5.70			57	93
5.79		1	57	93
5.80			57	93
5.90			57	93
5.94		A	57	93
5.95	15/64		57	93
6.00			57	93
6.05		B	63	101
6.10			63	101
6.15		C	63	101
6.20			63	101
6.25		D	63	101
6.30			63	101
6.35	1/4	E	63	101
6.40			63	101
6.50			63	101
6.53		F	63	101
6.60			63	101
6.63		G	63	101
6.70			63	101
6.75	17/64		69	109
6.76		H	69	109
6.80			69	109
6.90			69	109
6.91		I	69	109
7.00			69	109
7.04		J	69	109
7.10			69	109
7.14	9/32	K	69	109
7.20			69	109
7.30			69	109

Figures mentioned in Red are for reference only
Ground flutes upto 13 mm & milled flutes above 13 mm

Range of Application:
For general purpose use



TWIST DRILLS

Specifications conform to
IS 5101 : 2002
ISO 235 : 1980
BS 328 Part 1 : 1993
DIN 338 : 1984



TWIST DRILLS



Specifications conform to
 IS 5101 : 2002
 ISO 235 1980
 BS 328 Part 1 : 1993
 DIN 338 : 1984

High Speed Steel PARALLEL SHANK TWIST DRILLS (Jobber Series)

Size (h8)		Letter	Flute Length	Overall Length
mm	inch			
7.37		L	69	109
7.40			69	109
7.49		M	69	109
7.50			69	109
7.54	19/64		75	117
7.60			75	117
7.67		N	75	117
7.70			75	117
7.80			75	117
7.90			75	117
7.94	5/16		75	117
8.00			75	117
8.03		O	75	117
8.10			75	117
8.20		P	75	117
8.30			75	117
8.33	21/64		75	117
8.40			75	117
8.43		Q	75	117
8.50			75	117
8.60			81	125
8.61		R	81	125
8.70			81	125
8.73	11/32		81	125
8.80			81	125
8.84		S	81	125
8.90			81	125
9.00			81	125
9.09		T	81	125
9.10			81	125
9.13	23/64		81	125
9.20			81	125
9.30			81	125
9.35		U	81	125
9.40			81	125
9.50			81	125
9.52	3/8		87	133
9.58		V	87	133
9.60			87	133
9.70			87	133
9.80		W	87	133
9.90			87	133
9.92	25/64		87	133
10.00			87	133
10.08		X	87	133
10.10			87	133
10.20			87	133
10.26		Y	87	133
10.30			87	133

Figures mentioned in Red are for reference only
 Ground flutes upto 13 mm & milled flutes above 13 mm

Range of Application:
 For general purpose use

**High Speed Steel
PARALLEL SHANK TWIST DRILLS
(Jobber Series)**



Size (h8)			Flute Length	Overall Length
mm	inch	Letter		
10.32	13/32		87	133
10.40			87	133
10.49		Z	87	133
10.50			87	133
10.60			87	133
10.72	27/64		94	142
10.80			94	142
10.90			94	142
11.00			94	142
11.10			94	142
11.11	7/16		94	142
11.20			94	142
11.30			94	142
11.40			94	142
11.50			94	142
11.51	29/64		94	142
11.60			94	142
11.70			94	142
11.80			94	142
11.90			101	151
11.91	15/32		101	151
12.00			101	151
12.10			101	151
12.20			101	151
12.30	31/64		101	151
12.40			101	151
12.50			101	151
12.60			101	151
12.70	1/2		101	151
12.80			101	151
12.90			101	151
13.00			101	151
13.10			101	151
13.20			101	151
13.30			108	160
13.40			108	160
13.49	17/32		108	160
13.50			108	160
13.60			108	160
13.70			108	160
13.80			108	160
13.89	35/64		108	160
13.90			108	160
14.00			108	160
14.25			114	169
14.29	9/16		114	169
14.50			114	169
14.68	37/64		114	169
14.75			114	169

Figures mentioned in Red are for reference only
Ground flutes upto 13 mm & milled flutes above 13 mm

Range of Application:
For general purpose use



TWIST DRILLS

Specifications conform to
IS 5101 : 2002
ISO 235 : 1980
BS 328 Part 1 : 1993
DIN 338 : 1984



TWIST DRILLS



Specifications conform to
 IS 5101 : 2002
 ISO 235 1980
 BS 328 Part 1 : 1993
 DIN 338 : 1984

High Speed Steel PARALLEL SHANK TWIST DRILLS (Jobber Series)

Size (h8)		Flute Length	Overall Length
mm	inch		
15.00		114	169
15.08	19/32	120	178
15.25		120	178
15.48	39/64	120	178
15.50		120	178
15.75		120	178
15.87	5/8	120	178
16.00		120	178
16.25		125	184
16.27	41/64	125	184
16.50		125	184
16.67	21/32	125	184
16.75		125	184
17.00		125	184
17.07	43/64	130	191
17.25		130	191
17.46	11/16	130	191
17.50		130	191
17.75		130	191
17.86	45/64	130	191
18.00		130	191
18.25		135	198
18.26	23/32	135	198
18.50		135	198
18.65	47/64	135	198
18.75		135	198
19.00		135	198
19.05	3/4	140	205
19.25		140	205
19.45	49/64	140	205
19.50		140	205
19.75		140	205
19.84	25/32	140	205
20.00		140	205

Figures mentioned in Red are for reference only
 Ground flutes upto 13 mm & milled flutes above 13 mm

Range of Application:
 For general purpose use

**High Speed Steel
PARALLEL SHANK TWIST DRILLS
(Long Series)**



Size (h8)			Flute Length	Overall Length
mm	inch	No.		
1.00			33	56
1.02		60	33	56
1.04		59	33	56
1.07		58	37	60
1.09		57	37	60
1.10			37	60
1.18		56	37	60
1.19	3/64		41	65
1.20			41	65
1.30			41	65
1.32		55	41	65
1.40		54	45	70
1.50			45	70
1.51		53	50	76
1.59	1/16		50	76
1.60			50	76
1.61		52	50	76
1.70		51	50	76
1.78		50	53	80
1.80			53	80
1.85		49	53	80
1.90			53	80
1.93		48	56	85
1.98	5/64		56	85
1.99		47	56	85
2.00			56	85
2.06		46	56	85
2.08		45	56	85
2.10			56	85
2.18		44	59	90
2.20			59	90
2.26		43	59	90
2.30			59	90
2.37		42	62	95
2.38	3/32		62	95
2.40			62	95
2.44		41	62	95
2.49		40	62	95
2.50			62	95
2.53		39	62	95
2.58		38	62	95
2.60			62	95
2.64		37	62	95
2.70			66	100
2.71		36	66	100

Figures mentioned in Red are for reference only
Ground flutes upto 13 mm & milled flutes above 13 mm

Range of Application:

For drilling deep or inaccessible holes or for use in conjunction with drill bushing



TWIST DRILLS

Specifications conform to
IS 5102 : 2002
ISO 494 : 1975
BS 328 Part 1 : 1993
DIN 340 : 1978



TWIST DRILLS



Specifications conform to
 IS 5102 : 2002
 ISO 494 : 1975
 BS 328 Part 1 : 1993
 DIN 340 : 1978

High Speed Steel PARALLEL SHANK TWIST DRILLS (Long Series)

Size (h8)			Flute Length	Overall Length
mm	inch	No.		
2.78	7/64		66	100
2.79		35	66	100
2.80			66	100
2.82		34	66	100
2.87		33	66	100
2.90			66	100
2.95		32	66	100
3.00			66	100
3.05		31	69	106
3.10			69	106
3.17	1/8		69	106
3.20			69	106
3.26		30	69	106
3.30			69	106
3.40			73	112
3.45		29	73	112
3.50			73	112
3.57	9/64	28	73	112
3.60			73	112
3.66		27	73	112
3.70			73	112
3.73		26	73	112
3.80		25	78	119
3.86		24	78	119
3.90			78	119
3.91		23	78	119
3.97	5/32		78	119
3.99		22	78	119
4.00			78	119
4.04		21	78	119
4.09		20	78	119
4.10			78	119
4.20			78	119
4.22		19	78	119
4.30		18	82	126
4.37	11/64		82	126
4.39		17	82	126
4.40			82	126
4.50		16	82	126
4.57		15	82	126
4.60			82	126
4.62		14	82	126
4.70		13	82	126
4.76	3/16		87	132
4.80		12	87	132
4.85		11	87	132
4.90			87	132
4.91		10	87	132
4.98		9	87	132

Figures mentioned in Red are for reference only
 Ground flutes upto 13 mm & milled flutes above 13 mm

Range of Application:

For drilling deep or inaccessible holes or for use in conjunction with drill bushing

**High Speed Steel
PARALLEL SHANK TWIST DRILLS
(Long Series)**



Size (h8)			Flute Length	Overall Length
mm	inch	No./Letter		
5.00			87	132
5.05		8	87	132
5.10			87	132
5.11		7	87	132
5.16	13/64		87	132
5.18		6	87	132
5.20			87	132
5.22		5	87	132
5.30			87	132
5.31		4	91	139
5.40			91	139
5.41		3	91	139
5.50			91	139
5.56	7/32		91	139
5.60			91	139
5.61		2	91	139
5.70			91	139
5.79		1	91	139
5.80			91	139
5.90			91	139
5.94		A	91	139
5.95	15/64		91	139
6.00			91	139
6.05		B	97	148
6.10			97	148
6.15		C	97	148
6.20			97	148
6.25		D	97	148
6.30			97	148
6.35	1/4	E	97	148
6.40			97	148
6.50			97	148
6.53		F	97	148
6.60			97	148
6.63		G	97	148
6.70			97	148
6.75	17/64		102	156
6.76		H	102	156
6.80			102	156
6.90			102	156
6.91		I	102	156
7.00			102	156
7.04		J	102	156
7.10			102	156
7.14	9/32	K	102	156
7.20			102	156
7.30			102	156
7.37		L	102	156
7.40			102	156
7.49		M	102	156
7.50			102	156



TWIST DRILLS

Specifications conform to
IS 5102 : 2002
ISO 494 : 1975
BS 328 Part 1 : 1993
DIN 340 : 1978

Figures mentioned in Red are for reference only
Ground flutes upto 13 mm & milled flutes above 13 mm

Range of Application:

For drilling deep or inaccessible holes or for use in conjunction with drill bushing



TWIST DRILLS



Specifications conform to
 IS 5102 : 2002
 ISO 494 : 1975
 BS 328 Part 1 : 1993
 DIN 340 : 1978

High Speed Steel PARALLEL SHANK TWIST DRILLS (Long Series)

Size (h8)			Flute Length	Overall Length
mm	inch	Letter		
7.54	19/64		109	165
7.60			109	165
7.67		N	109	165
7.70			109	165
7.80			109	165
7.90			109	165
7.94	5/16		109	165
8.00			109	165
8.03		O	109	165
8.10			109	165
8.20		P	109	165
8.30			109	165
8.33	21/64		109	165
8.40			109	165
8.43		Q	109	165
8.50			109	165
8.60			115	175
8.61		R	115	175
8.70			115	175
8.73	11/32		115	175
8.80			115	175
8.84		S	115	175
8.90			115	175
9.00			115	175
9.09		T	115	175
9.10			115	175
9.13	23/64		115	175
9.20			115	175
9.30			115	175
9.35		U	115	175
9.40			115	175
9.50			115	175
9.52	3/8		121	184
9.58		V	121	184
9.60			121	184
9.70			121	184
9.80		W	121	184
9.90			121	184
9.92	25/64		121	184
10.00			121	184
10.08		X	121	184
10.10			121	184
10.20			121	184
10.26		Y	121	184
10.30			121	184
10.32	13/32		121	184
10.40			121	184
10.49		Z	121	184
10.50			121	184

Figures mentioned in Red are for reference only
 Ground flutes upto 13 mm & milled flutes above 13 mm

Range of Application:

For drilling deep or inaccessible holes or for use in conjunction with drill bushing

**High Speed Steel
PARALLEL SHANK TWIST DRILLS
(Long Series)**



Size (h8)		Flute Length	Overall Length
mm	inch		
10.60		121	184
10.70		128	195
10.72	27/64	128	195
11.11	7/16	128	195
11.30		128	195
11.40		128	195
11.50		128	195
11.51	29/64	128	195
11.60		128	195
11.70		128	195
11.80		128	195
11.90		134	205
11.91	15/32	134	205
12.00		134	205
12.10		134	205
12.20		134	205
12.30	31/64	134	205
12.40		134	205
12.50		134	205
12.60		134	205
12.70	1/2	134	205
12.80		134	205
12.90		134	205
13.00		134	205
13.10		134	205
13.20		134	205
13.30		140	214
13.40		140	214
13.49	17/32	140	214
13.50		140	214
13.60		140	214
13.70		140	214
13.80		140	214
13.89	35/64	140	214
13.90		140	214
14.00		140	214
14.25		144	220
14.29	9/16	144	220
14.50		144	220
14.68	37/64	144	220
14.75		144	220
15.00		144	220
15.08	19/32	149	227
15.25		149	227
15.48	39/64	149	227
15.50		149	227
15.75		149	227
15.87	5/8	149	227
16.00		149	227
16.25		154	235

Figures mentioned in Red are for reference only
Ground flutes upto 13 mm & milled flutes above 13 mm

Range of Application:

For drilling deep or inaccessible holes or for use in conjunction with drill bushing



TWIST DRILLS

Specifications conform to
IS 5102 : 2002
ISO 494 : 1975
BS 328 Part 1 : 1993
DIN 340 : 1978



TWIST DRILLS



Specifications conform to
 IS 5102 : 2002
 ISO 494 : 1975
 BS 328 Part 1 : 1993
 DIN 340 : 1978

High Speed Steel PARALLEL SHANK TWIST DRILLS (Long Series)

Size (h8)		Flute Length	Overall Length
mm	inch		
16.27	41/64	154	235
16.50		154	235
16.67	21/32	154	235
16.75		154	235
17.00		154	235
17.07	43/64	158	241
17.25		158	241
17.46	11/16	158	241
17.50		158	241
17.75		158	241
17.86	45/64	158	241
18.00		158	241
18.25		162	247
18.26	23/32	162	247
18.50		162	247
18.65	47/64	162	247
18.75		162	247
19.00		162	247
19.05	3/4	166	254
19.25		166	254
19.45	49/64	166	254
19.50		166	254
19.75		166	254
19.84	25/32	166	254
20.00		166	254
20.24	51/64	171	261
20.25		171	261
20.50		171	261
20.64	13/16	171	261
20.75		171	261
21.00		171	261
21.03	53/64	171	261
21.25		176	268
21.43	27/32	176	268
21.50		176	268
21.75		176	268
21.83	55/64	176	268
22.00		176	268
22.22	7/8	176	268
22.25		176	268
22.50		180	275
22.62	57/64	180	275
22.75		180	275
23.00		180	275
23.02	29/32	180	275
23.25		180	275
23.42	59/64	180	275
23.50		180	275

Figures mentioned in Red are for reference only
 Ground flutes upto 13 mm & milled flutes above 13 mm

Range of Application:

For drilling deep or inaccessible holes or for use in conjunction with drill bushing

**High Speed Steel
PARALLEL SHANK TWIST DRILLS
(Long Series)**



Size (h8)		Flute Length	Overall Length
mm	inch		
23.75		185	282
23.81	15/16	185	282
24.00		185	282
24.21	61/64	185	282
24.25		185	282
24.50		185	282
24.61	31/32	185	282
24.75		185	282
25.00	63/64	185	282
25.25		190	290
25.40	1	190	290
25.50		190	290
25.75		190	290
26.00		190	290
26.19	1.1/32	190	290
26.25		190	290
26.50		190	290
26.75		195	298
26.99	1.1/16	195	298
27.00		195	298
27.25		195	298
27.50		195	298
27.75		195	298
27.78	1.3/32	195	298
28.00		195	298
28.25		201	307
28.50		201	307
28.57	1.1/8	201	307
28.75		201	307
29.00		201	307
29.25		201	307
29.37	1.5/32	201	307
29.50		201	307
29.75		201	307
30.00		201	307
30.16	1.3/16	207	316
30.25		207	316
30.50		207	316
30.75		207	316
30.96	1.7/32	207	316
31.00		207	316
31.25		207	316
31.50		207	316

Figures mentioned in Red are for reference only
Ground flutes upto 13 mm & milled flutes above 13 mm



TWIST DRILLS

Specifications conform to
IS 5102 : 2002
ISO 494 : 1975
BS 328 Part 1 : 1993
DIN 340 : 1978

Range of Application:

For drilling deep or inaccessible holes or for use in conjunction with drill bushing



TWIST DRILLS



Specifications conform to
IS 7823 - 2005
ISO 3292 - 1995

High Speed Steel PARALLEL SHANK TWIST DRILLS (Extra Long Series)

Preferred Size (h8)			Series 1		Series 2		Series 3		Series 4	
mm	inch	NO.	FL	OAL	FL	OAL	FL	OAL	FL	OAL
3.00			100	160	150	200				
3.05		31	100	160	150	200				
3.10			100	160	150	200				
3.17	1/8		100	160	150	200				
3.20			100	160	150	200				
3.26		30	100	160	150	200				
3.30			100	160	150	200				
3.40			100	160	150	200				
3.45		29	100	160	150	200				
3.50			100	160	150	200	200	250		
3.57	9/64	28	100	160	150	200	200	250		
3.60			100	160	150	200	200	250		
3.66		27	100	160	150	200	200	250		
3.70			100	160	150	200	200	250		
3.73		26	100	160	150	200	200	250		
3.80		25	100	160	150	200	200	250		
3.86		24	100	160	150	200	200	250		
3.90			100	160	150	200	200	250		
3.91		23	100	160	150	200	200	250		
3.97	5/32		100	160	150	200	200	250		
3.99		22	100	160	150	200	200	250		
4.00			100	160	150	200	200	250	250	315
4.04		21	100	160	150	200	200	250	250	315
4.09		20	100	160	150	200	200	250	250	315
4.10			100	160	150	200	200	250	250	315
4.20			100	160	150	200	200	250	250	315
4.22		19	100	160	150	200	200	250	250	315
4.30		18	100	160	150	200	200	250	250	315
4.37	11/64		100	160	150	200	200	250	250	315
4.39		17	100	160	150	200	200	250	250	315
4.40			100	160	150	200	200	250	250	315
4.50		16	100	160	150	200	200	250	250	315
4.57		15	100	160	150	200	200	250	250	315
4.60			100	160	150	200	200	250	250	315
4.62		14	100	160	150	200	200	250	250	315
4.70		13	100	160	150	200	200	250	250	315
4.76	3/16		150	200	200	250	250	315	300	400
4.80		12	150	200	200	250	250	315	300	400
4.85		11	150	200	200	250	250	315	300	400
4.90			150	200	200	250	250	315	300	400
4.91		10	150	200	200	250	250	315	300	400
4.98		9	150	200	200	250	250	315	300	400
5.00			150	200	200	250	250	315	300	400
5.06		8	150	200	200	250	250	315	300	400
5.10			150	200	200	250	250	315	300	400
5.11		7	150	200	200	250	250	315	300	400
5.16	13/64		150	200	200	250	250	315	300	400

Figures mentioned in Red are for reference only
Ground flutes upto 13 mm & milled flutes above 13 mm

Range of Application:

For difficult drilling conditions in extremely deep holes.

**High Speed Steel
PARALLEL SHANK TWIST DRILLS
(Extra Long Series)**



Preferred Size(h8)			Series 1		Series 2		Series 3		Series 4	
mm	inch	NO/Ltr	FL	OAL	FL	OAL	FL	OAL	FL	OAL
5.18		6	150	200	200	250	250	315	300	400
5.20			150	200	200	250	250	315	300	400
5.22		5	150	200	200	250	250	315	300	400
5.30			150	200	200	250	250	315	300	400
5.31		4	150	200	200	250	250	315	300	400
5.40			150	200	200	250	250	315	300	400
5.41		3	150	200	200	250	250	315	300	400
5.50			150	200	200	250	250	315	300	400
5.56	7/32		150	200	200	250	250	315	300	400
5.60			150	200	200	250	250	315	300	400
5.61		2	150	200	200	250	250	315	300	400
5.70			150	200	200	250	250	315	300	400
5.79		1	150	200	200	250	250	315	300	400
5.80			150	200	200	250	250	315	300	400
5.90			150	200	200	250	250	315	300	400
5.94		A	150	200	200	250	250	315	300	400
5.95	15/64		150	200	200	250	250	315	300	400
6.00			150	200	200	250	250	315	300	400
6.04		B	150	200	200	250	250	315	300	400
6.10			150	200	200	250	250	315	300	400
6.15		C	150	200	200	250	250	315	300	400
6.20			150	200	200	250	250	315	300	400
6.25		D	150	200	200	250	250	315	300	400
6.30			150	200	200	250	250	315	300	400
6.35	1/4	E	150	200	200	250	250	315	300	400
6.40			150	200	200	250	250	315	300	400
6.50			150	200	200	250	250	315	300	400
6.53		F	150	200	200	250	250	315	300	400
6.60			150	200	200	250	250	315	300	400
6.63		G	150	200	200	250	250	315	300	400
6.70			150	200	200	250	250	315	300	400
6.75	17/64	H	150	200	200	250	250	315	300	400
6.80			150	200	200	250	250	315	300	400
6.90		I	150	200	200	250	250	315	300	400
7.00			150	200	200	250	250	315	300	400
7.03		J	150	200	200	250	250	315	300	400
7.10			150	200	200	250	250	315	300	400
7.14	9/32	K	150	200	200	250	250	315	300	400
7.20			150	200	200	250	250	315	300	400
7.30			150	200	200	250	250	315	300	400
7.37		L	150	200	200	250	250	315	300	400
7.40			150	200	200	250	250	315	300	400
7.49		M	150	200	200	250	250	315	300	400
7.50			150	200	200	250	250	315	300	400
7.54	19/64		200	250	250	315	300	400		
7.60			200	250	250	315	300	400		
7.67		N	200	250	250	315	300	400		

Figures mentioned in Red are for reference only
Ground flutes upto 13 mm & milled flutes above 13 mm

Range of Application:

For difficult drilling conditions in extremely deep holes.



TWIST DRILLS

Specifications conform to
IS 7823 : 2005
ISO 3292 : 1995



TWIST DRILLS



Specifications conform to
IS 7823 : 2005
ISO 3292 : 1995

High Speed Steel PARALLEL SHANK TWIST DRILLS (Extra Long Series)

Preferred Size (h8)			Series 1		Series 2		Series 3	
mm	inch	Letter	FL	OAL	FL	OAL	FL	OAL
7.70			200	250	250	315	300	400
7.80			200	250	250	315	300	400
7.90			200	250	250	315	300	400
7.94	5/16		200	250	250	315	300	400
8.00			200	250	250	315	300	400
8.03		O	200	250	250	315	300	400
8.10			200	250	250	315	300	400
8.20		P	200	250	250	315	300	400
8.30			200	250	250	315	300	400
8.33	21/64		200	250	250	315	300	400
8.40			200	250	250	315	300	400
8.43		Q	200	250	250	315	300	400
8.50			200	250	250	315	300	400
8.60			200	250	250	315	300	400
8.61		R	200	250	250	315	300	400
8.70			200	250	250	315	300	400
8.73	11/32		200	250	250	315	300	400
8.80			200	250	250	315	300	400
8.84		S	200	250	250	315	300	400
8.90			200	250	250	315	300	400
9.00			200	250	250	315	300	400
9.09		T	200	250	250	315	300	400
9.10			200	250	250	315	300	400
9.13	23/64		200	250	250	315	300	400
9.20			200	250	250	315	300	400
9.30			200	250	250	315	300	400
9.34		U	200	250	250	315	300	400
9.40			200	250	250	315	300	400
9.50			200	250	250	315	300	400
9.52	3/8		200	250	250	315	300	400
9.58		V	200	250	250	315	300	400
9.60			200	250	250	315	300	400
9.70			200	250	250	315	300	400
9.80		W	200	250	250	315	300	400
9.90			200	250	250	315	300	400
9.92	25/64		200	250	250	315	300	400
10.00			200	250	250	315	300	400
10.08		X	200	250	250	315	300	400
10.10			200	250	250	315	300	400
10.20			200	250	250	315	300	400
10.26			200	250	250	315	300	400
10.30			200	250	250	315	300	400
10.32	13/32		200	250	250	315	300	400
10.40			200	250	250	315	300	400
10.49		Z	200	250	250	315	300	400
10.50			200	250	250	315	300	400
10.60			200	250	250	315	300	400

Figures mentioned in Red are for reference only
Ground flutes upto 13 mm & milled flutes above 13 mm

Range of Application:

For difficult drilling conditions in extremely deep holes.

**High Speed Steel
PARALLEL SHANK TWIST DRILLS
(Extra Long Series)**



Preferred Size (h8)		Series 1		Series 2		Series 3	
mm	inch		OAL		OAL		OAL
10.70		200	250	250	315	300	400
10.72	27/64	200	250	250	315	300	400
10.80		200	250	250	315	300	400
10.90		200	250	250	315	300	400
11.00		200	250	250	315	300	400
11.10		200	250	250	315	300	400
11.11	7/16	200	250	250	315	300	400
11.20		200	250	250	315	300	400
11.30		200	250	250	315	300	400
11.40		200	250	250	315	300	400
11.50		200	250	250	315	300	400
11.51	29/64	200	250	250	315	300	400
11.60		200	250	250	315	300	400
11.70		200	250	250	315	300	400
11.80		200	250	250	315	300	400
11.90		200	250	250	315	300	400
11.91	15/32	200	250	250	315	300	400
12.00		200	250	250	315	300	400
12.10		200	250	250	315	300	400
12.20		200	250	250	315	300	400
12.30	31/64	200	250	250	315	300	400
12.40		200	250	250	315	300	400
12.50		200	250	250	315	300	400
12.60		200	250	250	315	300	400
12.70	1/2	200	250	250	315	300	400
12.80		200	250	250	315	300	400
12.90		200	250	250	315	300	400
13.00		200	250	250	315	300	400
13.10		200	250	250	315	300	400
13.20		200	250	250	315	300	400
13.30		200	250	250	315	300	400
13.40		200	250	250	315	300	400
13.50		200	250	250	315	300	400
13.60		200	250	250	315	300	400
13.70		200	250	250	315	300	400
13.80		200	250	250	315	300	400
13.90		200	250	250	315	300	400
14.00		200	250	250	315	300	400

Figures mentioned in Red are for reference only
Ground flutes upto 13 mm & milled flutes above 13 mm



TWIST DRILLS

Specifications conform to
IS 7823 : 2005
ISO 3292 : 1995

Range of Application:

For difficult drilling conditions in extremely deep holes.



TWIST DRILLS



Specifications conform to
 IS 5103 : 2002
 ISO 235/1 : 1980
 BS 328 Part 1 : 1993
 DIN 345 : 1978

High Speed Steel TAPER SHANK TWIST DRILLS (With Standard Shank)

Size (h8)			Flute Length	Overall Length	MT Shank No
mm	inch	No			
3.00			33	114	1
3.05		31	36	117	1
3.10			36	117	1
3.17	1/8		36	117	1
3.20			36	117	1
3.26		30	36	117	1
3.30			36	117	1
3.40			39	120	1
3.45		29	39	120	1
3.50			39	120	1
3.57	9/64	28	39	120	1
3.60			39	120	1
3.66		27	39	120	1
3.70			39	120	1
3.73		26	39	120	1
3.80		25	43	124	1
3.86		24	43	124	1
3.90			43	124	1
3.91		23	43	124	1
3.97	5/32		43	124	1
3.99		22	43	124	1
4.00			43	124	1
4.04		21	43	124	1
4.09		20	43	124	1
4.10			43	124	1
4.20			43	124	1
4.22		19	43	124	1
4.30		18	47	128	1
4.37	11/64		47	128	1
4.39		17	47	128	1
4.40			47	128	1
4.50		16	47	128	1
4.57		15	47	128	1
4.60			47	128	1
4.62		14	47	128	1
4.70		13	47	128	1
4.76	3/16		52	133	1
4.80		12	52	133	1
4.85		11	52	133	1
4.90			52	133	1
4.91		10	52	133	1
4.98		9	52	133	1
5.00			52	133	1
5.06		8	52	133	1
5.10			52	133	1
5.11		7	52	133	1
5.16	13/64		52	133	1

Figures mentioned in **Red** are for reference only

Range of Application:
 For general purpose use.

**High Speed Steel
TAPER SHANK TWIST DRILLS
(With Standard Shank)**



Size (h8)			Flute Length	Overall Length	MT Shank No
mm	inch	No/Letter			
5.18		6	52	133	1
5.20			52	133	1
5.22		5	52	133	1
5.30			52	133	1
5.31		4	57	138	1
5.40			57	138	1
5.41		3	57	138	1
5.50			57	138	1
5.56	7/32		57	138	1
5.60			57	138	1
5.61		2	57	138	1
5.70			57	138	1
5.79		1	57	138	1
5.80			57	138	1
5.90			57	138	1
5.94		A	57	138	1
5.95	15/64		57	138	1
6.00			57	138	1
6.05		B	63	144	1
6.10			63	144	1
6.15		C	63	144	1
6.20			63	144	1
6.25		D	63	144	1
6.30			63	144	1
6.35	1/4	E	63	144	1
6.40			63	144	1
6.50			63	144	1
6.53		F	63	144	1
6.60			63	144	1
6.63		G	63	144	1
6.70			63	144	1
6.75	17/64		69	150	1
6.76		H	69	150	1
6.80			69	150	1
6.90			69	150	1
6.91		I	69	150	1
7.00			69	150	1
7.04		J	69	150	1
7.10			69	150	1
7.14	9/32	K	69	150	1
7.20			69	150	1
7.30			69	150	1
7.37		L	69	150	1
7.40			69	150	1
7.49		M	69	150	1
7.50			69	150	1
7.54	19/64		75	156	1
7.60			75	156	1
7.67		N	75	156	1

Figures mentioned in **Red** are for reference only
Range of Application:
For general purpose use.



TWIST DRILLS

Specifications conform to
IS 5103 : 2002
ISO 235/1 : 1980
BS 328 Part 1 : 1993
DIN 345 : 1978



TWIST DRILLS



Specifications conform to
 IS 5103 : 2002
 ISO 235/1 : 1980
 BS 328 Part 1 : 1993
 DIN 345 : 1978

High Speed Steel TAPER SHANK TWIST DRILLS (With Standard Shank)

Size (h8)			Flute Length	Overall Length	MT Shank No
mm	inch	Letter			
7.70			75	156	1
7.80			75	156	1
7.90			75	156	1
7.94	5/16		75	156	1
8.00			75	156	1
8.03		O	75	156	1
8.10			75	156	1
8.20		P	75	156	1
8.30			75	156	1
8.33	21/64		75	156	1
8.40			75	156	1
8.43		Q	75	156	1
8.50			75	156	1
8.60			81	162	1
8.61		R	81	162	1
8.70			81	162	1
8.73	11/32		81	162	1
8.80			81	162	1
8.84		S	81	162	1
8.90			81	162	1
9.00			81	162	1
9.09		T	81	162	1
9.10			81	162	1
9.13	23/64		81	162	1
9.20			81	162	1
9.30			81	162	1
9.35		U	81	162	1
9.40			81	162	1
9.50			81	162	1
9.52	3/8		87	168	1
9.58		V	87	168	1
9.60			87	168	1
9.70			87	168	1
9.80		W	87	168	1
9.90			87	168	1
9.92	25/64		87	168	1
10.00			87	168	1
10.08		X	87	168	1
10.10			87	168	1
10.20			87	168	1
10.26		Y	87	168	1
10.30			87	168	1
10.32	13/32		87	168	1
10.40			87	168	1
10.49		Z	87	168	1
10.50			87	168	1
10.60			87	168	1

Figures mentioned in **Red** are for reference only

Range of Application:
 For general purpose use.

**High Speed Steel
TAPER SHANK TWIST DRILLS
(With Standard Shank)**



Size (h8)		Flute Length	Overall Length	MT Shank No
mm	inch			
10.70		94	175	1
10.72	27/64	94	175	1
10.80		94	175	1
10.90		94	175	1
11.00		94	175	1
11.10		94	175	1
11.11	7/16	94	175	1
11.20		94	175	1
11.30		94	175	1
11.40		94	175	1
11.50		94	175	1
11.51	29/64	94	175	1
11.60		94	175	1
11.70		94	175	1
11.80		94	175	1
11.90		101	182	1
11.91	15/32	101	182	1
12.00		101	182	1
12.10		101	182	1
12.20		101	182	1
12.30	31/64	101	182	1
12.40		101	182	1
12.50		101	182	1
12.60		101	182	1
12.70	1/2	101	182	1
12.80		101	182	1
12.90		101	182	1
13.00		101	182	1
13.10	33/64	101	182	1
13.20		101	182	1
13.30		108	189	1
13.40		108	189	1
13.49	17/32	108	189	1
13.50		108	189	1
13.60		108	189	1
13.70		108	189	1
13.80		108	189	1
13.89	35/64	108	189	1
13.90		108	189	1
14.00		108	189	1
14.25		114	212	2
14.29	9/16	114	212	2
14.50		114	212	2
14.68	37/64	114	212	2
14.75		114	212	2
15.00		114	212	2
15.08	19/32	120	218	2

Figures mentioned in **Red** are for reference only

Range of Application:
For general purpose use.



TWIST DRILLS

Specifications conform to
IS 5103 : 2002
ISO 235/1 : 1980
BS 328 Part 1 : 1993
DIN 345 : 1978



TWIST DRILLS



Specifications conform to
 IS 5103 : 2002
 ISO 235/1 : 1980
 BS 328 Part 1 : 1993
 DIN 345 : 1978

High Speed Steel TAPER SHANK TWIST DRILLS (With Standard Shank)

Size (h8)		Flute Length	Overall Length	MT Shank No
mm	inch			
15.25		120	218	2
15.48	39/64	120	218	2
15.50		120	218	2
15.75		120	218	2
15.87	5/8	120	218	2
16.00		120	218	2
16.25		125	223	2
16.27	41/64	125	223	2
16.50		125	223	2
16.67	21/32	125	223	2
16.75		125	223	2
17.00		125	223	2
17.07	43/64	130	228	2
17.25		130	228	2
17.46	11/16	130	228	2
17.50		130	228	2
17.75		130	228	2
17.86	45/64	130	228	2
18.00		130	228	2
18.25		135	233	2
18.26	23/32	135	233	2
18.50		135	233	2
18.65	47/64	135	233	2
18.75		135	233	2
19.00		135	233	2
19.05	3/4	140	238	2
19.25		140	238	2
19.45	49/64	140	238	2
19.50		140	238	2
19.75		140	238	2
19.84	25/32	140	238	2
20.00		140	238	2
20.24	51/64	145	243	2
20.25		145	243	2
20.50		145	243	2
20.64	13/16	145	243	2
20.75		145	243	2
21.00		145	243	2
21.03	53/64	145	243	2
21.25		150	248	2
21.43	27/32	150	248	2
21.50		150	248	2
21.75		150	248	2
21.83	55/64	150	248	2
22.00		150	248	2
22.22	7/8	150	248	2
22.25		150	248	2

Figures mentioned in **Red** are for reference only

Range of Application:
 For general purpose use.

**High Speed Steel
TAPER SHANK TWIST DRILLS
(With Standard Shank)**



Size (h8)		Flute Length	Overall Length	MT Shank No
mm	inch			
22.50		155	253	2
22.62	57/64	155	253	2
22.75		155	253	2
23.00		155	253	2
23.02	29/32	155	253	2
23.25		155	276	3
23.42	59/64	155	276	3
23.50		155	276	3
23.75		160	281	3
23.81	15/16	160	281	3
24.00		160	281	3
24.21	61/64	160	281	3
24.25		160	281	3
24.50		160	281	3
24.61	31/32	160	281	3
24.75		160	281	3
25.00	63/64	160	281	3
25.25		165	286	3
25.40	1	165	286	3
25.50		165	286	3
25.75		165	286	3
26.00		165	286	3
26.19	1.1/32	165	286	3
26.25		165	286	3
26.50		165	286	3
26.75		170	291	3
26.99	1.1/16	170	291	3
27.00		170	291	3
27.25		170	291	3
27.50		170	291	3
27.75		170	291	3
27.78	1.3/32	170	291	3
28.00		170	291	3
28.25		175	296	3
28.50		175	296	3
28.57	1.1/8	175	296	3
28.75		175	296	3
29.00		175	296	3
29.25		175	296	3
29.37	1.5/32	175	296	3
29.50		175	296	3
29.75		175	296	3
30.00		175	296	3
30.16	1.3/16	180	301	3
30.25		180	301	3
30.50		180	301	3
30.75		180	301	3

Figures mentioned in **Red** are for reference only

Range of Application:
For general purpose use.



TWIST DRILLS

Specifications conform to
IS 5103 : 2002
ISO 235/1 : 1980
BS 328 Part 1 : 1993
DIN 345 : 1978



TWIST DRILLS



Specifications conform to
 IS 5103 : 2002
 ISO 235/1 : 1980
 BS 328 Part 1 : 1993
 DIN 345 : 1978

High Speed Steel TAPER SHANK TWIST DRILLS (With Standard Shank)

Size (h8)		Flute Length	Overall Length	MT Shank No
mm	inch			
30.96	1.7/32	180	301	3
31.00		180	301	3
31.25		180	301	3
31.50		180	301	3
31.75	1.1/4	185	306	3
32.00		185	334	4
32.50		185	334	4
32.54	1.9/32	185	334	4
33.00		185	334	4
33.34	1.5/16	185	334	4
33.50		185	334	4
34.00		190	339	4
34.13	1.11/32	190	339	4
34.50		190	339	4
34.92	1.3/8	190	339	4
35.00		190	339	4
35.50		190	339	4
35.72	1.13/32	195	344	4
36.00		195	344	4
36.50		195	344	4
36.51	1.7/16	195	344	4
37.00		195	344	4
37.31	1.15/32	195	344	4
37.50		195	344	4
38.00		200	349	4
38.10	1.1/2	200	349	4
38.50		200	349	4
38.89	1.17/32	200	349	4
39.00		200	349	4
39.50		200	349	4
39.69	1.9/16	200	349	4
40.00		200	349	4
40.48	1.19/32	205	354	4
40.50		205	354	4
41.00		205	354	4
41.27	1.5/8	205	354	4
41.50		205	354	4
42.00		205	354	4
42.07	1.21/32	205	354	4
42.50		205	354	4
42.86	1.11/16	210	359	4
43.00		210	359	4
43.50		210	359	4
43.66	1.23/32	210	359	4
44.00		210	359	4
44.45	1.3/4	210	359	4
44.50		210	359	4

Figures mentioned in **Red** are for reference only

Range of Application:
 For general purpose use.

**High Speed Steel
TAPER SHANK TWIST DRILLS
(With Standard Shank)**



Size (h8)		Flute Length	Overall Length	MT Shank No
mm	inch			
45.00		210	359	4
45.24	1.25/32	215	364	4
45.50		215	364	4
46.00		215	364	4
46.04	1.13/16	215	364	4
46.50		215	364	4
46.83	1.27/32	215	364	4
47.00		215	364	4
47.50		215	364	4
47.62	1.7/8	220	369	4
48.00		220	369	4
48.42	1.29/32	220	369	4
48.50		220	369	4
49.00		220	369	4
49.21	1.15/16	220	369	4
49.50		220	369	4
50.00		220	369	4
50.01	1.31/32	225	374	4
50.50		225	374	4
50.80	2	225	374	4
51.00		225	412	5
52.00		225	412	5
52.39	2.1/16	225	412	5
53.00		225	412	5
53.97	2.1/8	230	417	5
54.00		230	417	5
55.00		230	417	5
55.56	2.3/16	230	417	5
56.00		230	417	5
57.00		235	422	5
57.15	2.1/4	235	422	5
58.00		235	422	5
58.74	2.5/16	235	422	5
59.00		235	422	5
60.00		235	422	5
60.32	2.3/8	240	427	5
61.00		240	427	5
61.91	2.7/16	240	427	5
62.00		240	427	5
63.00		240	427	5
63.50	2.1/2	245	432	5
64.00		245	432	5
65.00		245	432	5
65.09	2.9/16	245	432	5
66.00		245	432	5
66.67	2.5/8	245	432	5
67.00		245	432	5

Figures mentioned in **Red** are for reference only

Range of Application:
For general purpose use.



TWIST DRILLS

Specifications conform to
IS 5103 : 2002
ISO 235/1 : 1980
BS 328 Part 1 : 1993
DIN 345 : 1978



TWIST DRILLS



Specifications conform to
 IS 5103 : 2002
 ISO 235/1 : 1980
 BS 328 Part 1 : 1993
 DIN 345 : 1978

High Speed Steel TAPER SHANK TWIST DRILLS (With Standard Shank)

Size (h8)		Flute Length	Overall Length	MT Shank No
mm	inch			
68.00		250	437	5
68.26	2.11/16	250	437	5
69.00		250	437	5
69.85	2.3/4	250	437	5
70.00		250	437	5
71.00		250	437	5
71.44	2.13/16	255	442	5
72.00		255	442	5
73.00		255	442	5
73.02	2.7/8	255	442	5
74.00		255	442	5
74.61	2.15/16	255	442	5
75.00		255	442	5
76.00		260	447	5
76.20	3	260	447	5
77.00		260	514	6
77.79	3.1/16	260	514	6
78.00		260	514	6
79.00		260	514	6
79.37	3.1/8	260	514	6
80.00		260	514	6
80.96	3.3/16	265	519	6
81.00		265	519	6
82.00		265	519	6
82.55	3.1/4	265	519	6
83.00		265	519	6
84.00		265	519	6
84.14	3.5/16	265	519	6
85.00		265	519	6
85.72	3.3/8	270	524	6
86.00		270	524	6
87.00		270	524	6
87.31	3.7/16	270	524	6
88.00		270	524	6
88.90	3.1/2	270	524	6
89.00		270	524	6
90.00		270	524	6
90.49	3.9/16	275	529	6
91.00		275	529	6
92.00		275	529	6
92.07	3.5/8	275	529	6
93.00		275	529	6
93.66	3.11/16	275	529	6
94.00		275	529	6
95.00		275	529	6
95.25	3.3/4	280	534	6
96.00		280	534	6

Figures mentioned in **Red** are for reference only

Range of Application:
 For general purpose use.

**High Speed Steel
TAPER SHANK TWIST DRILLS
(With Standard Shank)**



Size (h8)		Flute Length	Overall Length	MT Shank No
mm	inch			
96.84	3.13/16	280	534	6
97.00		280	534	6
98.00		280	534	6
98.42	3.7/8	280	534	6
99.00		280	534	6
100.00		280	534	6
100.01	3.15/16	285	539	6
101.00		285	539	6
101.60	4	285	539	6
102.00		285	539	6
103.00		285	539	6
104.00		285	539	6
105.00		285	539	6
106.00		285	539	6

Figures mentioned in **Red** are for reference only



TWIST DRILLS

Specifications conform to
IS 5103 : 2002
ISO 235/1 : 1980
BS 328 Part 1 : 1993
DIN 345 : 1978

Range of Application:
For general purpose use.



TWIST DRILLS



Specifications conform to
 IS 5104 : 2002
 ISO 235/1 : 1980
 BS 328 Part 1 : 1993

High Speed Steel TAPER SHANK TWIST DRILLS (With Oversize Shank)

Size (h8)		Flute Length	Overall Length	MT Shank No
mm	inch			
11.91	15/32	101	199	2
12.00		101	199	2
12.10		101	199	2
12.20		101	199	2
12.30	31/64	101	199	2
12.40		101	199	2
12.50		101	199	2
12.60		101	199	2
12.70	½	101	199	2
12.80		101	199	2
12.90		101	199	2
13.00		101	199	2
13.10	33/64	101	199	2
13.20		101	199	2
13.30		108	206	2
13.40		108	206	2
13.49	17/32	108	206	2
13.50		108	206	2
13.60		108	206	2
13.70		108	206	2
13.80		108	206	2
13.89	35/64	108	206	2
13.90		108	206	2
14.00		108	206	2
14.25		114	235	3
14.29	9/16	114	235	3
14.50		114	235	3
14.68	37/64	114	235	3
14.75		114	235	3
15.00		114	235	3
15.08	19/32	120	241	3
15.25		120	241	3
15.48	39/64	120	241	3
15.50		120	241	3
15.75		120	241	3
15.87	5/8	120	241	3
16.00		120	241	3
16.25		125	246	3
16.27	41/64	125	246	3
16.50		125	246	3
16.67	21/32	125	246	3
16.75		125	246	3
17.00		125	246	3
17.07	43/64	130	251	3
17.25		130	251	3
17.46	11/16	130	251	3
17.50		130	251	3

Figures mentioned in **Red** are for reference only

Range of Application:

For General purpose use but with Oversize Taper Shank

**High Speed Steel
TAPER SHANK TWIST DRILLS
(With Oversize Shank)**



Size (h8)		Flute Length	Overall Length	MT Shank No
mm	inch			
17.75		130	251	3
17.86	45/64	130	251	3
18.00		130	251	3
18.25		135	256	3
18.26	23/32	135	256	3
18.50		135	256	3
18.65	47/64	135	256	3
18.75		135	256	3
19.00		135	256	3
19.05	3/4	140	261	3
19.25		140	261	3
19.45	49/64	140	261	3
19.50		140	261	3
19.75		140	261	3
19.84	25/32	140	261	3
20.00		140	261	3
20.24	51/64	145	266	3
20.25		145	266	3
20.50		145	266	3
20.64	13/16	145	266	3
20.75		145	266	3
21.00		145	266	3
21.03	53/64	145	266	3
21.25		150	271	3
21.43	27/32	150	271	3
21.50		150	271	3
21.75		150	271	3
21.83	55/64	150	271	3
22.00		150	271	3
22.22	7/8	150	271	3
22.25		150	271	3
22.50		155	276	3
22.62	29/32	155	276	3
22.75		155	276	3
23.00		155	276	3
23.02	29/32	155	304	4
23.25		155	304	4
23.42	59/64	155	304	4
23.50		155	304	4
23.75		160	309	4
23.81	15/16	160	309	4
24.00		160	309	4
24.21	61/64	160	309	4
24.25		160	309	4
24.50		160	309	4
24.61	31/32	160	309	4
24.75		160	309	4

Figures mentioned in **Red** are for reference only

Range of Application:

For General purpose use but with Oversize Taper Shank



TWIST DRILLS

Specifications conform to
IS 5104 : 2002
ISO 235/1 : 1980
BS 328 Part 1 : 1993



TWIST DRILLS



Specifications conform to
 IS 5104 : 2002
 ISO 235/1 : 1980
 BS 328 Part 1 : 1993

High Speed Steel TAPER SHANK TWIST DRILLS (With Oversize Shank)

Size (h8)		Flute Length	Overall Length	MT Shank No
mm	inch			
25.00	63/64	160	309	4
25.25		165	314	4
25.40	1	165	314	4
25.50		165	314	4
25.75		165	314	4
26.00		165	314	4
26.19	1.1/32	165	314	4
26.25		165	314	4
26.50		165	314	4
26.75		170	319	4
26.99	1.1/16	170	319	4
27.00		170	319	4
27.25		170	319	4
27.50		170	319	4
27.75		170	319	4
27.78	1.3/32	170	319	4
28.00		170	319	4
28.25		175	324	4
28.50		175	324	4
28.57	1.1/8	175	324	4
28.75		175	324	4
29.00		175	324	4
29.25		175	324	4
29.37	1.5/32	175	324	4
29.50		175	324	4
29.75		175	324	4
30.00		175	324	4
30.16	1.3/16	180	329	4
30.25		180	329	4
30.50		180	329	4
30.75		180	329	4
30.96	1.7/32	180	329	4
31.00		180	329	4
31.25		180	329	4
31.50		180	329	4
31.75	1.1/4	185	334	4
32.00		185	372	5
32.50		185	372	5
32.54	1.9/32	185	372	5
33.00		185	372	5
33.34	1.5/16	185	372	5
33.50		185	372	5r
34.00		190	377	5
34.13	1.11/32	190	377	5
34.50		190	377	5
34.92	1.3/8	190	377	5
35.00		190	377	5

Figures mentioned in **Red** are for reference only

Range of Application:

For General purpose use but with Oversize Taper Shank

**High Speed Steel
TAPER SHANK TWIST DRILLS
(With Oversize Shank)**



Size (h8)		Flute Length	Overall Length	MT Shank No
mm	inch			
35.72	1.13/32	195	382	5
36.00		195	382	5
36.50		195	382	5
36.51	1.7/16	195	382	5
37.00		195	382	5
37.31	1.15/32	195	382	5
37.50		195	382	5
38.00		200	387	5
38.10	1.1/2	200	387	5
38.50		200	387	5
38.89	1.17/32	200	387	5
39.00		200	387	5
39.50		200	387	5
39.69	1.9/16	200	387	5
40.00		200	387	5
40.48	1.19/32	205	392	5
40.50		205	392	5
41.00		205	392	5
41.27	1.5/8	205	392	5
41.50		205	392	5
42.00		205	392	5
42.07	1.21/32	205	392	5
42.50		205	392	5
42.86	1.11/16	210	397	5
43.00		210	397	5
43.50		210	397	5
43.66	1.23/32	210	397	5
44.00		210	397	5
44.45	1.3/4	210	397	5
44.50		210	397	5
45.00		210	397	5
45.24	1.25/32	215	402	5
45.50		215	402	5
46.00		215	402	5
46.04	1.13/16	215	402	5
46.50		215	402	5
46.83	1.27/32	215	402	5
47.00		215	402	5
47.50		215	402	5
47.62	1.7/8	220	407	5
48.00		220	407	5
48.42	1.29/32	220	407	5
48.50		220	407	5
49.00		220	407	5
49.21	1.15/16	220	407	5
49.50		220	407	5
50.00		220	407	5

Figures mentioned in **Red** are for reference only

Range of Application:

For General purpose use but with Oversize Taper Shank



TWIST DRILLS

Specifications conform to
IS 5104 : 2002
ISO 235/1 : 1980
BS 328 Part 1 : 1993



TWIST DRILLS



Specifications conform to
 IS 5104 : 2002
 ISO 235/1 : 1980
 BS 328 Part 1 : 1993

High Speed Steel TAPER SHANK TWIST DRILLS (With Oversize Shank)

Size (h8)		Flute Length	Overall Length	MT Shank No
mm	inch			
50.01	1.31/32	225	412	5
50.50		225	412	5
50.80	2	225	412	5
51.00		225	479	6
52.00		225	479	6
52.39	2.1/16	225	479	6
53.00		225	479	6
53.97	2.1/8	230	484	6
54.00		230	484	6
55.00		230	484	6
55.56	2.3/16	230	484	6
56.00		230	484	6
57.00		235	489	6
57.15	2.1/4	235	489	6
58.00		235	489	6
58.74	2.5/6	235	489	6
59.00		235	489	6
60.00		235	489	6
60.32	2.3/8	240	494	6
61.00		240	494	6
61.91	2.7/16	240	494	6
62.00		240	494	6
63.00		240	494	6
63.50	2.1/2	245	499	6
64.00		245	499	6
65.00		245	499	6
65.09	2.9/16	245	499	6
66.00		245	499	6
66.67	2.5/8	245	499	6
67.00		245	499	6
68.00		250	504	6
68.26	2.11/16	250	504	6
69.00		250	504	6
69.85	2.3/4	250	504	6
70.00		250	504	6
71.00		250	504	6
71.44	2.13/16	255	509	6
72.00		255	509	6
73.00		255	509	6
73.02	2.7/8	255	509	6
74.00		255	509	6
74.61	7.15/16	255	509	6
75.00		255	509	6
76.00		260	514	6
76.20	3	260	514	6

Figures mentioned in **Red** are for reference only

Range of Application:

For General purpose use but with Oversize Taper Shank

**High Speed Steel
TAPER SHANK TWIST DRILLS
(Long Series)**



Size (h8)			Flute Length	Overall Length	MT Shank No
mm	inch	No/Letter			
5.00			74	155	1
5.05		8	74	155	1
5.10			74	155	1
5.11		7	74	155	1
5.16	13/64		74	155	1
5.18		6	74	155	1
5.20			74	155	1
5.22		5	74	155	1
5.30			74	155	1
5.31		4	80	161	1
5.40			80	161	1
5.41		3	80	161	1
5.50			80	161	1
5.56	7/32		80	161	1
5.60			80	161	1
5.61		2	80	161	1
5.70			80	161	1
5.79		1	80	161	1
5.80			80	161	1
5.90			80	161	1
5.94		A	80	161	1
5.95	15/64		80	161	1
6.00			80	161	1
6.05		B	86	167	1
6.10			86	167	1
6.15		C	86	167	1
6.20			86	167	1
6.25		D	86	167	1
6.30			86	167	1
6.35	1/4	E	86	167	1
6.40			86	167	1
6.50			86	167	1
6.53		F	86	167	1
6.60			86	167	1
6.63		G	86	167	1
6.70			86	167	1
6.75	17/64		93	174	1
6.76		H	93	174	1
6.80			93	174	1
6.90			93	174	1
6.91		I	93	174	1
7.00			93	174	1
7.04		J	93	174	1
7.10			93	174	1
7.14	9/32	K	93	174	1
7.20			93	174	1
7.30			93	174	1
7.37		I	93	174	1

Figures mentioned in **Red** are for reference only

Range of Application:

Standard Drills for use with drill bushings and for deep hole drilling.



TWIST DRILLS

Specifications conform to
IS 8305 : 2002
DIN 341 : 1978



TWIST DRILLS



Specifications conform to
IS 8305 : 2002
DIN 341 : 1978

High Speed Steel TAPER SHANK TWIST DRILLS (Long Series)

Size (h8)			Flute Length	Overall Length	MT Shank No
mm	inch	Letter			
7.40			93	174	1
7.49		M	93	174	1
7.50			93	174	1
7.54	19/64		100	181	1
7.60			100	181	1
7.67		N	100	181	1
7.70			100	181	1
7.80			100	181	1
7.90			100	181	1
7.94	5/16		100	181	1
8.00			100	181	1
8.03		O	100	181	1
8.10			100	181	1
8.20		P	100	181	1
8.30			100	181	1
8.33	21/64		100	181	1
8.40			100	181	1
8.43		Q	100	181	1
8.50			100	181	1
8.60			107	188	1
8.61		R	107	188	1
8.70			107	188	1
8.73	11/32		107	188	1
8.80			107	188	1
8.84		S	107	188	1
8.90			107	188	1
9.00			107	188	1
9.09		T	107	188	1
9.10			107	188	1
9.13	23/64		107	188	1
9.20			107	188	1
9.30			107	188	1
9.35		U	107	188	1
9.40			107	188	1
9.50			107	188	1
9.52	3/8		116	197	1
9.58		V	116	197	1
9.60			116	197	1
9.70			116	197	1
9.80		W	116	197	1
9.90			116	197	1
9.92	25/64		116	197	1
10.00			116	197	1
10.08		X	116	197	1
10.10			116	197	1
10.20			116	197	1

Figures mentioned in **Red** are for reference only

Range of Application:

Standard Drills for use with drill bushings and for deep hole drilling.

**High Speed Steel
TAPER SHANK TWIST DRILLS
(Long Series)**



Size (h8)			Flute Length	Overall Length	MT Shank No
mm	inch	Letter			
10.26		Y	116	197	1
10.30			116	197	1
10.32	13/32		116	197	1
10.40			116	197	1
10.49		Z	116	197	1
10.50			116	197	1
10.60			116	197	1
10.70			125	206	1
10.72	27/64		125	206	1
10.80			125	206	1
10.90			125	206	1
11.00			125	206	1
11.10			125	206	1
11.11	7/16		125	206	1
11.20			125	206	1
11.30			125	206	1
11.40			125	206	1
11.50			125	206	1
11.51	29/64		125	206	1
11.60			125	206	1
11.70			125	206	1
11.80			125	206	1
11.90			134	215	1
11.91	15/32		134	215	1
12.00			134	215	1
12.20			134	215	1
12.30	31/64		134	215	1
12.40			134	215	1
12.50			134	215	1
12.60			134	215	1
12.70	1/2		134	215	1
12.80			134	215	1
12.90			134	215	1
13.00			134	215	1
13.10	33/61		134	215	1
13.20			134	215	1
13.30			142	223	1
13.40			142	223	1
13.49	17/32		142	223	1
13.50			142	223	1
13.60			142	223	1
13.70			142	223	1
13.80			142	223	1
13.89	35/64		142	223	1
13.90			142	223	1
14.00			142	223	1

Figures mentioned in **Red** are for reference only

Range of Application:

Standard Drills for use with drill bushings and for deep hole drilling.



TWIST DRILLS

Specifications conform to
IS 8305 : 2002
DIN 341 : 1978



TWIST DRILLS



Specifications conform to
IS 8305 : 2002
DIN 341 : 1978

High Speed Steel TAPER SHANK TWIST DRILLS (Long Series)

Size (h8)		Flute Length	Overall Length	MT Shank No
mm	inch			
14.25		147	245	2
14.29	9/16	147	245	2
14.50		147	245	2
14.68	37/64	147	245	2
14.75		147	245	2
15.00		147	245	2
15.08	19/32	153	251	2
15.25		153	251	2
15.48	39/64	153	251	2
15.50		153	251	2
15.75		153	251	2
15.87	5/8	153	251	2
16.00		153	251	2
16.25		159	257	2
16.27	41/64	159	257	2
16.50		159	257	2
16.67	21/32	159	257	2
16.75		159	257	2
17.00		159	257	2
17.07	43/64	165	263	2
17.25		165	263	2
17.46	11/16	165	263	2
17.50		165	263	2
17.75		165	263	2
17.86	45/64	165	263	2
18.00		165	263	2
18.25		171	269	2
18.26	23/32	171	269	2
18.50		171	269	2
18.65	47/64	171	269	2
18.75		171	269	2
19.00		171	269	2
19.05	3/4	177	275	2
19.25		177	275	2
19.45	49/64	177	275	2
19.50		177	275	2
19.75		177	275	2
19.84	25/32	177	275	2
20.00		177	275	2
20.24	51/64	184	282	2
20.25		184	282	2
20.50		184	282	2
20.64	13/16	184	282	2
20.75		184	282	2
21.00		184	282	2
21.03	53/64	184	282	2

Figures mentioned in **Red** are for reference only

Range of Application:

Standard Drills for use with drill bushings and for deep hole drilling.

**High Speed Steel
TAPER SHANK TWIST DRILLS
(Long Series)**



Size (h8)		Flute Length	Overall Length	MT Shank No
mm	inch			
21.25		191	289	2
21.43	27/32	191	289	2
21.50		191	289	2
21.75		191	289	2
21.83	55/64	191	289	2
22.00		191	289	2
22.22	7/8	191	289	2
22.25		191	289	2
22.50		198	296	2
22.62	57/64	198	296	2
22.75		198	296	2
23.00		198	296	2
23.02	29/32	198	296	2
23.25		198	319	3
23.42	59/64	198	319	3
23.50		198	319	3
23.75		206	327	3
23.81	15/16	206	327	3
24.00		206	327	3
24.21	61/64	206	327	3
24.25		206	327	3
24.50		206	327	3
24.61	31/32	206	327	3
24.75		206	327	3
25.00	63/64	206	327	3
25.25		214	335	3
25.40	1	214	335	3
25.50		214	335	3
25.75		214	335	3
26.00		214	335	3
26.19	1.1/32	214	335	3
26.25		214	335	3
26.50		214	335	3
26.75		222	343	3
26.99	1.1/16	222	343	3
27.00		222	343	3
27.25		222	343	3
27.50		222	343	3
27.75		222	343	3
27.78	1.3/32	222	343	3
28.00		222	343	3
28.25		230	351	3
28.50		230	351	3
28.58	1.1/8	230	351	3
28.75		230	351	3
29.00		230	351	3

Figures mentioned in **Red** are for reference only

Range of Application:

Standard Drills for use with drill bushings and for deep hole drilling.



TWIST DRILLS

Specifications conform to
IS 8305 : 2002
DIN 341 : 1978



TWIST DRILLS



Specifications conform to
IS 8305 : 2002
DIN 341 : 1978

High Speed Steel TAPER SHANK TWIST DRILLS (Long Series)

Size (h8)		Flute Length	Overall Length	MT Shank No
mm	inch			
29.25		230	351	3
29.37	1.5/32	230	351	3
29.50		230	351	3
29.75		230	351	3
30.00		230	351	3
30.16	1.3/16	239	360	3
30.25		239	360	3
30.50		239	360	3
30.75		239	360	3
30.96	1.7/32	239	360	3
31.00		239	360	3
31.25		239	360	3
31.50		239	360	3
31.75	1.1/4	248	369	3
32.00		248	397	4
32.50		248	397	4
32.54	1.9/32	248	397	4
33.00		248	397	4
33.34	1.5/16	248	397	4
33.50		248	397	4
34.00		257	406	4
34.13	1.11/32	257	406	4
34.50		257	406	4
34.92	1.3/8	257	406	4
35.00		257	406	4
35.50		257	406	4
35.72	1.13/32	267	416	4
36.00		267	416	4
36.50		267	416	4
36.51	1.7/16	267	416	4
37.00		267	416	4
37.31	1.15/32	267	416	4
37.50		267	416	4
38.00		277	426	4
38.10	1.1/2	277	426	4
38.50		277	426	4
38.89	1.17/32	277	426	4
39.00		277	426	4
39.50		277	426	4
39.69	1.9/16	277	426	4
40.00		277	426	4
40.48	1.19/32	287	436	4
40.50		287	436	4
41.00		287	436	4
41.28	1.5/8	287	436	4
41.50		287	436	4

Figures mentioned in **Red** are for reference only

Range of Application:

Standard Drills for use with drill bushings and for deep hole drilling.

**High Speed Steel
TAPER SHANK TWIST DRILLS
(Long Series)**



Size (h8)		Flute Length	Overall Length	MT Shank No
mm	inch			
42.00		287	436	4
42.07	1.21/32	287	436	4
42.50		287	436	4
42.86	1.11/16	298	447	4
43.00		298	447	4
43.50		298	447	4
43.66	1.23/32	298	447	4
44.00		298	447	4
44.45	1.3/4	298	447	4
44.50		298	447	4
45.00		298	447	4
45.24	1.25/32	310	459	4
45.50		310	459	4
46.00		310	459	4
46.04	1.13/16	310	459	4
46.50		310	459	4
46.83	1.27/32	310	459	4
47.00		310	459	4
47.50		310	459	4
47.62	1.7/8	321	470	4
48.00		321	470	4
48.42	1.29/32	321	470	4
48.50		321	470	4
49.00		321	470	4
49.21	1.15/16	321	470	4
49.50		321	470	4
50.00		321	470	4

Figures mentioned in **Red** are for reference only



TWIST DRILLS

Specifications conform to
IS 8305 : 2002
DIN 341 : 1978

Range of Application:
Standard Drills for use with drill bushings and for deep hole drilling.



TWIST DRILLS



Specifications conform to
 IS 7822 : 2005
 ISO 3291 : 1995

High Speed Steel TAPER SHANK TWIST DRILLS (Extra Long Series)

Preferred Size (h8)			Series 1		Series 2		Series 3		MT Shank No.
mm	inch	Letter	FL	OAL	FL	OAL	FL		
5.94		A	110	200	160	250	225	315	1
5.95	15/64		110	200	160	250	225	315	1
6.00			110	200	160	250	225	315	1
6.05		B	110	200	160	250	225	315	1
6.10			110	200	160	250	225	315	1
6.15		C	110	200	160	250	225	315	1
6.20			110	200	160	250	225	315	1
6.25		D	110	200	160	250	225	315	1
6.30			110	200	160	250	225	315	1
6.35	1/4	E	110	200	160	250	225	315	1
6.40			110	200	160	250	225	315	1
6.50			110	200	160	250	225	315	1
6.53		F	110	200	160	250	225	315	1
6.60			110	200	160	250	225	315	1
6.63		G	110	200	160	250	225	315	1
6.70			110	200	160	250	225	315	1
6.75	17/64		110	200	160	250	225	315	1
6.76		H	110	200	160	250	225	315	1
6.80			110	200	160	250	225	315	1
6.90			110	200	160	250	225	315	1
6.91		I	110	200	160	250	225	315	1
7.00			110	200	160	250	225	315	1
7.04		J	110	200	160	250	225	315	1
7.10			110	200	160	250	225	315	1
7.14	9/32	K	110	200	160	250	225	315	1
7.20			110	200	160	250	225	315	1
7.30			110	200	160	250	225	315	1
7.37		L	110	200	160	250	225	315	1
7.40			110	200	160	250	225	315	1
7.49		M	110	200	160	250	225	315	1
7.50			110	200	160	250	225	315	1
7.54	19/64		110	200	160	250	225	315	1
7.60			110	200	160	250	225	315	1
7.67		N	110	200	160	250	225	315	1
7.70			110	200	160	250	225	315	1
7.80			110	200	160	250	225	315	1
7.90			110	200	160	250	225	315	1
7.94	5/16		110	200	160	250	225	315	1
8.00			110	200	160	250	225	315	1
8.03		O	110	200	160	250	225	315	1
8.10			110	200	160	250	225	315	1
8.20		P	110	200	160	250	225	315	1
8.30			110	200	160	250	225	315	1
8.33	21/61		110	200	160	250	225	315	1
8.40			110	200	160	250	225	315	1
8.43		Q	110	200	160	250	225	315	1
8.50			110	200	160	250	225	315	1
8.60			110	200	160	250	225	315	1
8.61		R	110	200	160	250	225	315	1

Figures mentioned in **Red** are for reference only
Range of Application:
 For drilling extremely deep holes.

**High Speed Steel
TAPER SHANK TWIST DRILLS
(Extra Long Series)**



Preferred Size (h8)			Series 1		Series 2		Series 3		MT Shank No.
mm	inch	Letter	FL	OAL	FL	OAL	FL	OAL	
8.70			110	200	160	250	225	315	1
8.73	11/32		110	200	160	250	225	315	1
8.80			110	200	160	250	225	315	1
8.84		S	110	200	160	250	225	315	1
8.90			110	200	160	250	225	315	1
9.00			110	200	160	250	225	315	1
9.09		T	110	200	160	250	225	315	1
9.10			110	200	160	250	225	315	1
9.13	23/64		110	200	160	250	225	315	1
9.20			110	200	160	250	225	315	1
9.30			110	200	160	250	225	315	1
9.35		U	110	200	160	250	225	315	1
9.40			110	200	160	250	225	315	1
9.50			110	200	160	250	225	315	1
9.52	3/8		160	250	225	315	310	400	1
9.58		V	160	250	225	315	310	400	1
9.60			160	250	225	315	310	400	1
9.70			160	250	225	315	310	400	1
9.80		W	160	250	225	315	310	400	1
9.90			160	250	225	315	310	400	1
9.92	25/64		160	250	225	315	310	400	1
10.00			160	250	225	315	310	400	1
10.08		X	160	250	225	315	310	400	1
10.10			160	250	225	315	310	400	1
10.20			160	250	225	315	310	400	1
10.26			160	250	225	315	310	400	1
10.30			160	250	225	315	310	400	1
10.32	13/32		160	250	225	315	310	400	1
10.40			160	250	225	315	310	400	1
10.49		Z	160	250	225	315	310	400	1
10.50			160	250	225	315	310	400	1
10.60			160	250	225	315	310	400	1
10.70			160	250	225	315	310	400	1
10.72	27/64		160	250	225	315	310	400	1
10.80			160	250	225	315	310	400	1
10.90			160	250	225	315	310	400	1
11.00			160	250	225	315	310	400	1
11.10			160	250	225	315	310	400	1
11.11	7/16		160	250	225	315	310	400	1
11.20			160	250	225	315	310	400	1
11.30			160	250	225	315	310	400	1
11.40			160	250	225	315	310	400	1
11.50			160	250	225	315	310	400	1
11.51	29/64		160	250	225	315	310	400	1
11.60			160	250	225	315	310	400	1
11.70			160	250	225	315	310	400	1
11.80			160	250	225	315	310	400	1

Figures mentioned in **Red** are for reference only

Range of Application:
For drilling extremely deep holes.



TWIST DRILLS

Specifications conform to
IS 7822 : 2005
ISO 3291 : 1995



TWIST DRILLS



Specifications conform to
IS 7822 : 2005
ISO 3291 : 1995

High Speed Steel TAPER SHANK TWIST DRILLS (Extra Long Series)

Preferred Size (h8)		Series 1		Series 2		Series 3		MT Shank No.
mm	inch	FL	OAL	FL	OAL	FL	OAL	
11.90		160	250	225	315	310	400	1
11.91	15/32	160	250	225	315	310	400	1
12.00		160	250	225	315	310	400	1
12.10		160	250	225	315	310	400	1
12.20		160	250	225	315	310	400	1
12.30	31/64	160	250	225	315	310	400	1
12.40		160	250	225	315	310	400	1
12.50		160	250	225	315	310	400	1
12.60		160	250	225	315	310	400	1
12.70	1/2	160	250	225	315	310	400	1
12.80		160	250	225	315	310	400	1
12.90		160	250	225	315	310	400	1
13.00		160	250	225	315	310	400	1
13.10	33/64	160	250	225	315	310	400	1
13.20		160	250	225	315	310	400	1
13.30		160	250	225	315	310	400	1
13.40		160	250	225	315	310	400	1
13.49	17/32	160	250	225	315	310	400	1
13.50		160	250	225	315	310	400	1
13.60		160	250	225	315	310	400	1
13.70		160	250	225	315	310	400	1
13.80		160	250	225	315	310	400	1
13.89	35/64	160	250	225	315	310	400	1
13.90		160	250	225	315	310	400	1
14.00		160	250	225	315	310	400	1
14.25		215	315	300	400	400	500	2
14.29	9/16	215	315	300	400	400	500	2
14.50		215	315	300	400	400	500	2
14.68	37/64	215	315	300	400	400	500	2
14.75		215	315	300	400	400	500	2
15.00		215	315	300	400	400	500	2
15.08	19/32	215	315	300	400	400	500	2
15.75		215	315	300	400	400	500	2
15.87	5/8	215	315	300	400	400	500	2
16.00		215	315	300	400	400	500	2
16.25		215	315	300	400	400	500	2
16.27	41/64	215	315	300	400	400	500	2
16.50		215	315	300	400	400	500	2
16.67	21/32	215	315	300	400	400	500	2
16.75		215	315	300	400	400	500	2
17.00		215	315	300	400	400	500	2
17.07	43/64	215	315	300	400	400	500	2
17.25		215	315	300	400	400	500	2
17.46	11/16	215	315	300	400	400	500	2
17.50		215	315	300	400	400	500	2
17.75		215	315	300	400	400	500	2
17.86		215	315	300	400	400	500	2

Figures mentioned in **Red** are for reference only

Range of Application:
For drilling extremely deep holes.

**High Speed Steel
TAPER SHANK TWIST DRILLS
(Extra Long Series)**



Preferred Size (h8)		Series 1		Series 2		Series 3		MT Shank No.
mm	inch	FL	OAL	FL	OAL	FL	OAL	
18.00		215	315	300	400	400	500	2
18.25		215	315	300	400	400	500	2
18.26	23/32	215	315	300	400	400	500	2
18.50		215	315	300	400	400	500	2
18.65	47/64	215	315	300	400	400	500	2
18.75		215	315	300	400	400	500	2
19.00		215	315	300	400	400	500	2
19.05	3/4	215	315	300	400	400	500	2
19.25		215	315	300	400	400	500	2
19.45	49/64	215	315	300	400	400	500	2
19.50		215	315	300	400	400	500	2
19.75		215	315	300	400	400	500	2
19.84	25/32	215	315	300	400	400	500	2
20.00		215	315	300	400	400	500	2
20.24	51/64	215	315	300	400	400	500	2
20.25		215	315	300	400	400	500	2
20.50		215	315	300	400	400	500	2
20.64	13/16	215	315	300	400	400	500	2
20.75		215	315	300	400	400	500	2
21.00		215	315	300	400	400	500	2
21.03	53/64	215	315	300	400	400	500	2
21.25		215	315	300	400	400	500	2
21.43	27/32	215	315	300	400	400	500	2
21.50		215	315	300	400	400	500	2
21.75		215	315	300	400	400	500	2
21.83	55/64	215	315	300	400	400	500	2
22.00		215	315	300	400	400	500	2
22.22	7/8	215	315	300	400	400	500	2
22.25		215	315	300	400	400	500	2
22.50		215	315	300	400	400	500	2
22.62	57/64	215	315	300	400	400	500	2
22.75		215	315	300	400	400	500	2
23.00		215	315	300	400	400	500	2
23.02	29/32	275	400	375	500	505	630	3
23.25		275	400	375	500	505	630	3
23.42	59/64	275	400	375	500	505	630	3
23.50		275	400	375	500	505	630	3
23.75		275	400	375	500	505	630	3
23.81	15/16	275	400	375	500	505	630	3
24.00		275	400	375	500	505	630	3
24.21	61/64	275	400	375	500	505	630	3
24.25		275	400	375	500	505	630	3
24.50		275	400	375	500	505	630	3
24.61	31/32	275	400	375	500	505	630	3
24.75		275	400	375	500	505	630	3
25.00	63/64	275	400	375	500	505	630	3
25.25		275	400	375	500	505	630	3

Figures mentioned in **Red** are for reference only

Range of Application:
For drilling extremely deep holes.



TWIST DRILLS

Specifications conform to
IS 7822 : 2005
ISO 3291 : 1995



TWIST DRILLS



Specifications conform to
IS 7822 : 2005
ISO 3291 : 1995

High Speed Steel TAPER SHANK TWIST DRILLS (Extra Long Series)

Preferred Size (h8)		Series 1		Series 2		Series 3		MT Shank No.
mm	inch	FL	OAL	FL	OAL	FL	OAL	
25.40	1	275	400	375	500	505	630	3
25.50		275	400	375	500	505	630	3
25.75		275	400	375	500	505	630	3
26.00		275	400	375	500	505	630	3
26.19	1.1/32	275	400	375	500	505	630	3
26.25		275	400	375	500	505	630	3
26.50		275	400	375	500	505	630	3
26.75		275	400	375	500	505	630	3
26.99	1.1/16	275	400	375	500	505	630	3
27.00		275	400	375	500	505	630	3
27.25		275	400	375	500	505	630	3
27.50		275	400	375	500	505	630	3
27.75		275	400	375	500	505	630	3
27.78	1.3/32	275	400	375	500	505	630	3
28.00		275	400	375	500	505	630	3
28.25		275	400	375	500	505	630	3
28.50		275	400	375	500	505	630	3
28.57	1.1/8	275	400	375	500	505	630	3
28.75		275	400	375	500	505	630	3
29.00		275	400	375	500	505	630	3
29.25		275	400	375	500	505	630	3
29.37	1.5/32	275	400	375	500	505	630	3
29.50		275	400	375	500	505	630	3
29.75		275	400	375	500	505	630	3
30.00		275	400	375	500	505	630	3
30.16	1.3/16	250	400	350	500	480	630	4
30.25		250	400	350	500	480	630	4
30.50		250	400	350	500	480	630	4
30.75		250	400	350	500	480	630	4
30.96	1.7/32	250	400	350	500	480	630	4
31.00		250	400	350	500	480	630	4
31.25		250	400	350	500	480	630	4
31.50		250	400	350	500	480	630	4
31.75	1.1/4	250	400	350	500	480	630	4
32.00		250	400	350	500	480	630	4
32.50		250	400	350	500	480	630	4
32.54	1.9/32	250	400	350	500	480	630	4
33.00		250	400	350	500	480	630	4
33.34	1.5/16	250	400	350	500	480	630	4
33.50		250	400	350	500	480	630	4
34.00		250	400	350	500	480	630	4
34.13	1.11/32	250	400	350	500	480	630	4
34.50		250	400	350	500	480	630	4
34.92	1.3/8	250	400	350	500	480	630	4
35.00		250	400	350	500	480	630	4
35.50		250	400	350	500	480	630	4
35.72	1.13/32	250	400	350	500	480	630	4

Figures mentioned in **Red** are for reference only

Range of Application:
For drilling extremely deep holes.

**High Speed Steel
TAPER SHANK TWIST DRILLS
(Extra Long Series)**



Preferred Size (h8)		Series 1		Series 2		Series 3		MT Shank No.
mm	inch	FL	OAL	FL	OAL	FL	OAL	
36.00		250	400	350	500	480	630	4
36.50		250	400	350	500	480	630	4
36.51	1.7/16	250	400	350	500	480	630	4
37.00		250	400	350	500	480	630	4
37.31	1.15/32	250	400	350	500	480	630	4
37.50		250	400	350	500	480	630	4
38.00		250	400	350	500	480	630	4
38.10	1.1/2	250	400	350	500	480	630	4
38.50		250	400	350	500	480	630	4
38.89	1.17/32	250	400	350	500	480	630	4
39.00		250	400	350	500	480	630	4
39.50		250	400	350	500	480	630	4
39.69	1.9/16	250	400	350	500	480	630	4
40.00		250	400	350	500	480	630	4
40.48	1.19/32	350	500	480	630			4
40.50		350	500	480	630			4
41.00		350	500	480	630			4
41.27	1.5/8	350	500	480	630			4
41.50		350	500	480	630			4
42.00		350	500	480	630			4
42.07	1.21/32	350	500	480	630			4
42.50		350	500	480	630			4
42.86	1.11/16	350	500	480	630			4
43.00		350	500	480	630			4
43.50		350	500	480	630			4
43.66	1.23/32	350	500	480	630			4
44.00		350	500	480	630			4
44.45	1.3/4	350	500	480	630			4
44.50		350	500	480	630			4
45.00		350	500	480	630			4
45.24	1.25/32	350	500	480	630			4
45.50		350	500	480	630			4
46.00		350	500	480	630			4
46.04	1.13/16	350	500	480	630			4
46.50		350	500	480	630			4
46.83	1.27/32	350	500	480	630			4
47.00		350	500	480	630			4
47.50		350	500	480	630			4
47.62	1.7/8	350	500	480	630			4
48.00		350	500	480	630			4
48.42	1.29/32	350	500	480	630			4
48.50		350	500	480	630			4
49.00		350	500	480	630			4
49.21	1.15/16	350	500	480	630			4
49.50		350	500	480	630			4
50.00		350	500	480	630			4
50.01	1.31/32	350	500	480	630			4

Figures mentioned in **Red** are for reference only

Range of Application:
For drilling extremely deep holes.



TWIST DRILLS

Specifications conform to
IS 7822 : 2005
ISO 3291 : 1995



TWIST DRILLS



Specifications conform to
 IS 5366 : 2002
 ISO 7079 : 1981
 BS 328 Part 3 : 1990
 DIN 343 : 1981

High Speed Steel TAPER SHANK CORE DRILLS

Size (h8)		Flute Length	Overall Length	MT Shank No.
mm	inch			
7.94	5/16	75	156	1
8.00		75	156	1
8.10		75	156	1
8.20		75	156	1
8.30		75	156	1
8.33	21/64	75	156	1
8.40		75	156	1
8.50		75	156	1
8.60		81	162	1
8.70		81	162	1
8.70		81	162	1
8.73	11/32	81	162	1
8.80		81	162	1
8.90		81	162	1
9.00		81	162	1
9.10		81	162	1
9.13	23/64	81	162	1
9.20		81	162	1
9.30		81	162	1
9.40		81	162	1
9.50		81	162	1
9.52	3/8	87	168	1
9.60		87	168	1
9.70		87	168	1
9.80		87	168	1
9.90		87	168	1
9.92	25/64	87	168	1
10.00		87	168	1
10.10		87	168	1
10.20		87	168	1
10.30		87	168	1
10.32	13/32	87	168	1
10.40		87	168	1
10.50		87	168	1
10.60		87	168	1
10.70		94	175	1
10.72	27/64	94	175	1
10.80		94	175	1
10.90		94	175	1
11.00		94	175	1
11.10		94	175	1
11.11	7/16	94	175	1
11.20		94	175	1
11.30		94	175	1
11.40		94	175	1
11.50		94	175	1
11.51	29/64	94	175	1
11.60		94	175	1

Figures mentioned in **Red** are for reference only

Range of Application:

For enlarging diameter of Pre-drilled holes.

**High Speed Steel
TAPER SHANK CORE DRILLS**



Size (h8)		Flute Length	Overall Length	MT Shank No.
mm	inch			
11.70		94	175	1
11.80		94	175	1
11.90		101	182	1
11.91	15/32	101	182	1
12.00		101	182	1
12.10		101	182	1
12.20		101	182	1
12.30	31/64	101	182	1
12.40		101	182	1
12.50		101	182	1
12.60		101	182	1
12.70	1/2	101	182	1
12.90		101	182	1
13.00		101	182	1
13.10	33/64	101	182	1
13.20		101	182	1
13.30		108	189	1
13.40		108	189	1
13.49	17/32	108	189	1
13.50		108	189	1
13.60		108	189	1
13.70		108	189	1
13.80		108	189	1
13.89	35/64	108	189	1
13.90		108	189	1
14.00		108	189	1
14.25		114	212	2
14.29	9/16	114	212	2
14.50		114	212	2
14.68	37/64	114	212	2
14.75		114	212	2
15.00		114	212	2
15.08	19/32	120	218	2
15.25		120	218	2
15.48	39/64	120	218	2
15.50		120	218	2
15.75		120	218	2
15.87	5/8	120	218	2
16.00		120	218	2
16.25		125	223	2
16.27	41/64	125	223	2
16.50		125	223	2
16.67	21/32	125	223	2
16.75		125	223	2
17.00		125	223	2
17.07	43/64	130	228	2
17.25		130	228	2
17.46	11/16	130	228	2

Figures mentioned in **Red** are for reference only

Range of Application:

For enlarging diameter of pedrilled holes.



TWIST DRILLS

Specifications conform to
IS 5366 : 2002
ISO 7079 : 1981
BS 328 Part 3 : 1990
DIN 343 : 1981



TWIST DRILLS



Specifications conform to
 IS 5366 : 2002
 ISO 7079 : 1981
 BS 328 Part 3 : 1990
 DIN 343 : 1981

High Speed Steel TAPER SHANK CORE DRILLS

Size (h8)		Flute Length	Overall Length	MT Shank No.
mm	inch			
17.50		130	228	2
17.75		130	228	2
17.8		130	228	2
18.00		130	228	2
18.25		135	233	2
18.26	23/32	135	233	2
18.50		135	233	2
18.65	47/64	135	233	2
18.75		135	233	2
19.00		135	233	2
19.05	3/4	140	238	2
19.25		140	238	2
19.45	49/64	140	238	2
19.50		140	238	2
19.75		140	238	2
19.84	25/32	140	238	2
20.00		140	238	2
20.24	51/64	145	243	2
20.25		145	243	2
20.50		145	243	2
20.64	13/16	145	243	2
20.75		145	243	2
21.00		145	243	2
21.03	53/64	145	243	2
21.25		150	248	2
21.43	27/32	150	248	2
21.50		150	248	2
21.75		150	248	2
21.83	55/64	150	248	2
22.00		150	248	2
22.22	7/8	150	248	2
22.25		150	248	2
22.50		155	253	2
22.62	57/64	155	253	2
22.75		155	253	2
23.00		155	253	2
23.02	29/32	155	253	2
23.25		155	276	3
23.42	59/64	155	276	3
23.50		155	276	3
23.75		160	281	3
23.81	15/16	160	281	3
24.00		160	281	3
24.21	61/64	160	281	3
24.25		160	281	3
24.50		160	281	3
24.61	31/32	160	281	3
24.75		160	281	3

Figures mentioned in **Red** are for reference only
Range of Application:
 For enlarging diameter of Predrilled holes.

**High Speed Steel
TAPER SHANK CORE DRILLS**



Size (h8)		Flute Length	Overall Length	MT Shank No.
mm	inch			
25.00	63/64	160	281	3
25.25		165	286	3
25.40	1	165	286	3
25.50		165	286	3
25.75		165	286	3
26.00		165	286	3
26.19	1.1/32	165	286	3
26.25		165	286	3
26.50		165	286	3
26.75		170	291	3
26.99	1.1/16	170	291	3
27.00		170	291	3
27.25		170	291	3
27.50		170	291	3
27.75		170	291	3
27.78	1.3/32	170	291	3
28.00		170	291	3
28.25		175	296	3
28.50		175	296	3
28.58	1.1/8	175	296	3
28.75		175	296	3
29.00		175	296	3
29.25		175	296	3
29.37	1.5/32	175	296	3
29.50		175	296	3
29.75		175	296	3
30.00		175	296	3
30.16	1.3/16	180	301	3
30.25		180	301	3
30.50		180	301	3
30.75		180	301	3
30.96	1.7/32	180	301	3
31.00		180	301	3
31.25		180	301	3
31.50		180	301	3
31.75	1.1/4	185	306	3
32.00		185	334	4
32.50		185	334	4
32.54	1.9/32	185	334	4
33.00		185	334	4
33.34	1.5/16	185	334	4
33.50		185	334	4
34.00		190	339	4
34.13	1.11/32	190	339	4
34.50		190	339	4
34.92	1.3/8	190	339	4
35.00		190	339	4
35.50		190	339	4

Figures mentioned in **Red** are for reference only
Range of Application:
 For enlarging diameter of Pre drilled holes.



TWIST DRILLS

Specifications conform to
 IS 5366 : 2002
 ISO 7079 : 1981
 BS 328 Part 3 : 1990
 DIN 343 : 1981



TWIST DRILLS



Specifications conform to
 IS 5366 : 2002
 ISO 7079 : 1981
 BS 328 Part 3 : 1990
 DIN 343 : 1981

High Speed Steel TAPER SHANK CORE DRILLS

Size (h8)		Flute Length	Overall Length	MT Shank No.
mm	inch			
35.72	1.13/32	195	344	4
36.00		195	344	4
36.50		195	344	4
36.51	1.7/16	195	344	4
37.00		195	344	4
37.31	1.15/32	195	344	4
37.50		195	344	4
38.00		200	349	4
38.10	1.1/2	200	349	4
38.50		200	349	4
38.89	1.17/32	200	349	4
39.00		200	349	4
39.50		200	349	4
39.69	1.9/16	200	349	4
40.00		200	349	4
40.48	1.19/32	205	354	4
40.50		205	354	4
41.00		205	354	4
41.28	1.5/8	205	354	4
41.50		205	354	4
42.00		205	354	4
42.07	1.21/32	205	354	4
42.50		205	354	4
42.86	1.11/16	210	359	4
43.00		210	359	4
43.50		210	359	4
43.66	1.23/32	210	359	4
44.00		210	359	4
44.45	1.3/4	210	359	4
44.50		210	359	4
45.00		210	359	4
45.24	1.25/32	215	364	4
45.50		215	364	4
46.00		215	364	4
46.04	1.13/16	215	364	4
46.50		215	364	4
46.83	1.27/32	215	364	4
47.00		215	364	4
47.50		215	364	4
47.62	1.7/8	220	369	4
48.00		220	369	4
48.42	.29/32	220	369	4
48.50		220	369	4
49.00		220	369	4
49.21	1.15/16	220	369	4
49.50		220	369	4
50.00		220	369	4

Figures mentioned in **Red** are for reference only

Range of Application:
 For enlarging diameter of Predrilled holes.

**High Speed Steel
SHELL CORE DRILLS
(Taper Bore 1:30)**



Nominal diameter (h8)	Diameter of Large end of Taper Bore	Overall Length
25	13	45
26	13	45
27	13	45
28	13	45
29	13	45
30	13	45
31	13	45
32	13	45
33	13	45
34	13	45
35	13	45
36	16	50
37	16	50
38	16	50
39	16	50
40	16	50
41	16	50
42	16	50
43	16	50
44	16	50
45	16	50
46	19	56
47	19	56
48	19	56
50	19	56
52	19	56
55	22	63
58	22	63
60	22	63
62	22	63
65	27	71
70	27	71
72	27	71
75	27	71
80	32	80
85	32	80
90	32	80
95	40	90
100	40	90



TWIST DRILLS

Dimensions in mm
Specifications conform to
IS 7772 : 2002
ISO 3314 : 1975

Range of Application:
For enlarging diameter of Predrilled holes.
Common arbors can be used with different diameters of these drills



TWIST DRILLS



Dimensions in inches
Specifications conform to
BS 328 Part 4 : 1990

High Speed Steel SHELL CORE DRILLS Taper Bore (1/8 in 12 in on Dia)

Nominal diameter (h8)	Diameter of Large end of Taper Bore	Cutting Edge Length	Overall Length
1	5/8	2.1/4	2.3/4
1.1/16	5/8	2.1/4	2.3/4
1.1/8	5/8	2.1/4	2.3/4
1.3/16	5/8	2.1/4	2.3/4
1.1/4	5/8	2.1/4	2.3/4
1.5/16	3/4	2.3/8	3
1.3/8	3/4	2.3/8	3
1.7/16	3/4	2.3/8	3
1.1/2	3/4	2.3/8	3
1.9/16	3/4	2.3/8	3
1.5/8	3/4	2.3/8	3
1.11/16	1	2.3/4	3.1/2
1.3/4	1	2.3/4	3.1/2
1.13/16	1	2.3/4	3.1/2
1.7/8	1	2.3/4	3.1/2
1.15/16	1	2.3/4	3.1/2
2	1	2.3/4	3.1/2
2.1/8	1.1/4	3	3.3/4
2.1/4	1.1/4	3	3.3/4
2.3/8	1.1/4	3	3.3/4
2.1/2	1.1/2	3.1/4	4
2.5/8	1.1/2	3.1/4	4
2.3/4	1.1/2	3.1/4	4
2.7/8	1.1/2	3.1/4	4
3	1.1/2	3.1/4	4
3.1/8	1.3/4	3.3/4	4.1/2
3.1/4	1.3/4	3.3/4	4.1/2
3.3/8	1.3/4	3.3/4	4.1/2
3.1/2	1.3/4	3.3/4	4.1/2
3.5/8	2	4.1/4	5
3.3/4	2	4.1/4	5
3.7/8	2	4.1/4	5
4	2	4.1/4	5

Range of Application:

For enlarging diameter of Predrilled holes.
Common arbors can be used with different diameters of these drills

**High Speed Steel
CENTRE DRILL
Type - A**



Pilot Diameter (k12)	Body Diameter (h9)	Overall Length		Pilot Length	
		Max	Min	Max	Min
1.00	3.15	33.50	29.50	1.90	1.30
1.25	3.15	33.50	29.50	2.20	1.60
1.60	4.00	37.50	33.50	2.80	2.00
2.00	5.00	42.00	38.00	3.30	2.50
2.50	6.30	47.00	43.00	4.10	3.10
3.15	8.00	52.00	48.00	4.90	3.90
4.00	10.00	59.00	53.00	6.20	5.00
5.00	12.50	66.00	60.00	7.50	6.30
6.30	16.00	74.00	68.00	9.20	8.00
8.00	20.00	83.00	77.00	11.50	10.10
10.00	25.00	103.00	97.00	14.20	12.80



TWIST DRILLS

Dimensions in mm
Specifications conform to
IS 6708 : 2002
ISO 866 : 1975
DIN 333 : 1986

Range of Application:
For producing centre holes form A



TWIST DRILLS



Dimensions in mm
Specifications conform to
IS 6709 : 2002
ISO 2540 : 1972
DIN 333 : 1986

High Speed Steel CENTRE DRILLS Type - B

Pilot Diameter (k12)	Body Diameter (h9)	Overall Length		Pilot Length	
		Max	Min	Max	Min
1.60	6.30	47.00	43.00	2.80	2.00
2.00	8.00	52.00	48.00	3.30	2.50
2.50	10.00	59.00	53.00	4.10	3.10
3.15	11.20	63.00	57.00	4.90	3.90
4.00	14.00	70.00	64.00	6.20	5.00
(5.00)	18.00	78.00	72.00	7.50	6.30
6.30	20.00	83.00	77.00	9.20	8.00
(8.00)	25.00	103.00	97.00	11.50	10.10
10.00	31.50	128.00	122.00	14.20	12.80

**High Speed Steel
CENTRE DRILLS
Type - R**



Pilot Dia (k12)	Body Dia (h9)	Overall Length		Cutting Edge Length	Radius	
		Max	Min		Max	Min
1.00	3.15	33.50	29.50	3.00	3.15	2.50
(1.25)	3.15	33.50	29.50	3.35	4.00	3.15
1.60	4.00	37.50	33.50	4.25	5.00	4.00
2.00	5.00	42.00	38.00	5.30	6.30	5.00
2.50	6.30	47	43	6.7	8.0	6.30
3.15	8.00	52.00	48.00	8.50	10.00	8.00
4.00	10.00	59.00	53.00	10.60	12.50	10.00
(5.00)	12.50	66.00	60.00	13.20	16.00	12.50
6.30	16.00	74.00	68.00	17.00	20.00	16.00
(8.00)	20.00	83.00	77.00	21.20	25.00	20.00
10.00	25.00	103.00	97.00	26.50	31.50	25.00



TWIST DRILLS

Dimensions in mm
Specifications conform to
IS 6710 : 2002
ISO 2541 : 1972
DIN 333 : 1986

Range of Application:
For producing radius type centre hole form R



TWIST DRILLS



Dimensions in Inches
Specifications conform to
BS 328 Part 2 : 1990

High Speed Steel CENTRE DRILLS Inch Sizes

B. S. No.	Body Diameter	Pilot Diameter		Pilot Length	Overall Length	
		Max	Min		Size	Tol ±
1	1/8	3/64	5/64	1/16	1.1/2	1/32
2	3/16	1/16	3/32	5/64	1.3/4	1/32
3	1/4	3/32	5/32	1/8	2	1/16
4	5/16	1/8	3/16	5/32	2.1/4	1/16
5	7/16	3/16	9/32	1/4	2.1/2	3/32
6	5/8	1/4	3/8	5/16	3	3/32
7	3/4	5/16	15/32	13/32	3.1/2	3/32

**High Speed Steel
SUBLAND TWIST DRILLS
With Parallel Shank**



Large Dia (h8)	Small Dia (h9)	Overall Length	Flute Length (Total)	Small Dia Length	Thread Size
9.00	6.80	125.00	81.00	21.00	M 8x1.25
11.00	8.50	142.00	94.00	25.50	M10x1.50
14.00	10.20	160.00	108.00	30.00	M 12x1.75
15.50	12.00	178.00	120.00	34.50	M 14x2.00



TWIST DRILLS

Dimension in mm
Specification conform to:
IS 12691 : 1999
ISO 3439 : 1975
DIN 8378 : 1981

Range of Application:
For producing holes prior to Tapping Screw Threads

65



**High Speed Steel
SUBLAND TWIST DRILLS
With Taper Shank**

Large Diameter (h8)	Small Diameter (h9)	Overall Length	Flute Length (Total)	Small Dia Length	MT Shank No	Thread Size
9.00	6.80	162	81	21	1	M 8x1.25
11.00	8.50	175	94	25.5	1	M 10x1.50
14.00	10.20	189	108	30	1	M 12x1.75
16.00	12.00	218	120	34.5	2	M 14x2.00
18.00	14.00	228	130	38.5	2	M 16x2.00
20.00	15.50	238	140	43.5	2	M 18x2.50
22.00	17.50	248	150	47.5	2	M 20x2.50
24.00	19.50	281	160	51.5	3	M 22x2.50
26.00	21.00	286	165	56.5	3	M 24x3.00
30.00	24.00	296	175	62.5	3	M 27x3.00
33.00	26.50	334	185	70	4	M 30x3.50

TWIST DRILLS



Dimension in mm
Specification conform to:
IS 12687 : 1999
ISO 3438 : 1975
DIN 8379 : 1981

66

Range of Application:
For producing holes prior to Tapping Screw Threads

**High Speed Steel
TAPER SHANK TWIST DRILLS
For Taper Pin Holes - with Taper 1:50**



Nominal diameter	Small End diameter	Large End diameter	Overall Length	Parallel diameter Length	Flute Length	MT Shank No.
5	4.98	6.62	164	6	86	1
6	5.97	8.25	196	6	117	1
8	7.97	10.69	222	10	143	1
10	9.96	13.12	244	10	165	1
12	11.96	15.70	293	15	198	2
16	15.95	21.07	362	15	267	2
20	19.95	25.15	393	22	278	3
25	24.94	30.88	433	22	313	3
32	31.93	37.99	472	30	327	4
40	39.92	46.22	500	40	348	4
50	49.90	56.42	550	50	368	5



TWIST DRILLS

Dimension in mm
Specification conform to:
IS 5364 : 2002

Range of Application:
For drilling holes suitable for standard Taper Pins



TWIST DRILLS



Specifications conforms to:
ITM Standard

68

MASONRY DRILLS - CARBIDE TIPPED (Ground Fluted & Bright Plated)

Size		Flute Length	Overall Length
mm			
3	1/8	40	76
4	5/32	45	85
5	3/16	45	87
5.5	7/32	45	87
6	15/64	60	107
6.5	1/4	60	107
7	9/32	60	107
8	5/16	80	120
9	11/32	80	120
10	3/8	80	120
11	7/16	115	160
12	15/32	115	160
13	1/2	115	160

Range of Application :

For Drilling on traditional building materials such as concrete, stone work, bricks, tiles, slats, marbles, granites etc.



TECHNICAL SUPPLY CONDITIONS OF “DAGGER DRILLS”

1. Twist Drills are normally supplied for RH Cutting, Type 'N', with a point angle ground to 118° and lip clearance angle minimum 8°
2. Intermediate diameters, if ordered, shall be supplied with the same dimensions as of the next bigger diameter.
3. Parallel shank Drills are normally made without driving tenon.
4. Taper shank Drills are normally supplied with Morse taper according to IS: 1715 – Dimensions for self-holding tapers.
5. Non standard or special drills are manufactured against specific orders.
6. Inch sizes drills are not recommended by Bureau of Indian Standards.
7. Other general requirements are maintained according to IS: 5099 – Technical Supply conditions for twist drills.
 - 7.1 Hardness :

Cutting portion	:	760 HV to 900 HV.
Shank portion	:	240 HV to Maximum hardness equal to cutting portion (in case of one piece construction) 185 HV to 450 HV (in case of two piece construction)
Tang of Morse Taper	:	Sizes below 10 mm 185 HV minimum and for sizes 10mm and above 300 HV to 450 HV
Driving tenon	:	240 HV to maximum hardness equal to cutting portion.
 - 7.2 Drills are provided with a back taper of 0.02 to 0.08 mm per 100 mm flute length.
 - 7.3 Drills are maintained with radial run out (Tr) which is calculated by equation
 $Tr = 0.03 + 0.01 L/d$ (where L = Total length & d = Drill diameter).
 - 7.4 Twist drills are marked where diameter is 3 mm and above – Drill diameter, Material (HSS) and Trademark of Indian Tool Manufacturers
In case of twist drills below 3 mm diameter the marking shall be on the packing box only.
8. Twist drills according to DIN, B.S. and ANSI are also manufactured against specific requirement.



HELIX ANGLE FOR TWIST DRILLS

Diameter		Helix Angles		
Over	Up to and incl.	Type - N	Type - H	Type - S
1.0	3.2	22°-28°	11°-15°	31°-36°
3.20	5.0	24°-30°	11°-15°	33°-38°
5.0	10.0	25°-31°	12°-17°	34°-40°
10.0	40.0	27°-34°	13°-17°	37°-42°
40.0	50.0	29°-38	14°-19°	39°-46°

The drills are made in three types for Normal (N), Hard (H) and Soft (S) work piece materials. These type designations are based on the material to be cut and design requirements of drills.



TYPES OF DRILL POINTS

FOR VARIOUS APPLICATIONS

118° Point ; General purpose point for most materials where work hardening or chip formation does not present a problem.

135° Point ; a greater point angle is used for tough or hard materials such as highly alloyed steels.

90° Point ; a smaller point angle is used for soft and highly ductile materials such as plastics and non-ferrous metals.

Standard point with 45° Chamfer ; a corner chamfer is used to reduce burr in soft materials or reduce corner breakdown in abrasive materials.

Split or crankshaft point this type is used to reduce thrust when hand drilling tough materials or to make self-centering for NC equipment.

CUTTING FLUIDS	
Hard Tool and Alloy steel	Soluble oil compound or neat cutting oil
Low Carbon steel	Soluble oil
Copper brass or bronze	Soluble oil or dry
Aluminium and magnesium alloys	Soluble oil or neat cutting oil specially produced for light alloys.
Cast iron	dry or compressed air.
Stainless steel Nimonic alloys Monel metals	Soluble oils can be used but Sulphurised or chlorinated mineral or fatty oils are most suitable.
Zinc base alloys Mazak	Soluble oil



Speeds & Feeds for H.S.S. Drills

Work Piece Material	Cutting Speed M/min	Drill Diameter in mm									
			1	2	5	8	12	16	25	40	63
Steel *45 Kg.mm ²	35 - 40	f n	Hand 12000	0.05 6000	0.12 2400	0.2 1500	0.25 1000	0.3 750	0.4 480	0.4 300	0.5 190
Steel *45 - 70 Kg.mm ²	30 - 35	f n	Hand 10000	0.05 5000	0.12 2100	0.2 1300	0.25 850	0.3 640	0.4 410	0.4 260	0.5 165
Steel *Above 70 Kg.mm ²	15 - 25	f n	Hand 8000	0.04 4000	0.1 1600	0.15 995	0.2 680	0.25 500	0.3 318	0.3 200	0.4 125
Alloy Steel *Above 100 Kg.mm ²	8 - 15	f n	Hand 3650	Hand 1840	0.06 735	0.1 455	0.15 305	0.2 230	0.3 145	0.3 90	0.3 80
Cast iron Up to 18 Kg.mm ²	20 - 30	f n	Hand 8000	0.07 4000	0.12 1600	0.2 1000	0.3 660	0.4 500	0.5 320	0.6 200	0.6 127
Cast Iron Above 18 - 30 Kg.mm ²	5 - 15	f n	Hand 3180	Hand 1600	0.1 635	0.2 400	0.3 265	0.4 200	0.5 130	0.6 80	0.6 50
Mang. Steel Above 15%	3 - 5	f n	Hand 1300	Hand 650	0.05 255	0.08 160	0.1 110	0.1 80	0.15 50	0.2 32	0.2 20
Stainless Steel	6 - 12	f n	Hand 2800	Hand 1400	0.05 570	0.1 360	0.12 240	0.15 180	0.2 110	0.2 70	0.3 45
Brass - Brittle	80 - 100	f n	Hand 28000	0.08 14000	0.2 5700	0.25 3600	0.3 2400	0.4 1800	0.5 1100	0.6 700	0.7 450
Brass - Ductile	50 - 60	f n	Hand 17500	0.05 8700	0.15 3500	0.25 2200	0.3 1500	0.4 1100	0.5 700	0.6 440	0.7 280
Copper & Zinc alloy	50 - 70	f n	Hand 16000	0.04 8000	0.14 3200	0.18 2000	0.22 1325	0.25 1000	0.3 650	0.45 400	0.5 250
Aluminium long Chipped	80 - 120	f n	Hand 32000	0.05 16000	0.14 6350	0.2 4000	0.25 2650	0.3 2000	0.4 1280	0.45 800	0.5 500
Aluminium Short Chipped	120 - 160	f n	Hand 38000	0.06 19000	0.16 7600	0.25 4800	0.35 3200	0.4 2400	0.5 1520	0.65 1000	0.7 600

f = Feed in mm rev
n = R.P.M
* = Tensile Strength



TYPICAL DRILL FAILURES

OBSERVATION	REASON	REMEDY
Splitting up of drills	Axial play in the drilling spindle Springy clamping of work piece. Excessive feed	Remove the play of the Spindle.
Breakage of drill	Improper holding in chuck. Insufficient Chip removal. Incorrectly ground drill	Clamp drill rigidly. Remove chip frequently. Grind drill in time as recommended
Drill catching and breaking	Blow holes in job. Slanting or irregular surface at drill exit	Decrease feed. Drill carefully by hand.
Land Washed off	Cutting speed too high. Insufficient Coolant	Reduce speed. Sufficient coolant to be fed to cutting zone-under pressure, if necessary.
Tilting up of machine. Drill springs back while emerging.	Feed too heavy. Machine too weak	Reduce feed. Do not overload machine
Burrs on straight shank drill	Drill insecurely clamped, Heavy feed. Drill flutes clogged with chips.	Clamp drill rigidly, reduce feed, remove chips frequently.
Tenon broken or damaged.	Socket not free from dirt, oil, burrs or metal damming in receiving socket.	Clean socket, remove burrs. If necessary, change sleeve.
Drill point showing sign of over - heating.	High cutting speed. Insufficient coolant. If used for drilling deep holes, feed is excessive.	Reduce R.P.M. Arrange for sufficient coolant For deep hole reduce feed.
Hole produced more than normal diameter.	Drill incorrectly ground. Cutting edges not symmetric	Grind drill correctly. Check with gauge.
Drilled hole showing metal damming at entry and burrs on exit surface.	Drill blunt. Burrs formation could be due to excessive feed.	Drill to be reground in time.
Poor surface finish of drilled hole.	Drill blunt. Feed excessive. Incorrect and insufficient coolant.	Sharpen drill. Reduce feed. Arrange for proper and sufficient coolant.
Drilled hole is oval	Excessive feed, causing drill to bend. Drill point is shifted from axis of drill. Drill running out.	Reduce feed. Align job with point. Arrange for Exact drill running.



HIGH SPEED STEELS USED FOR CUTTING TOOLS

Depending on the application, cutting tools are manufactured using different grades of HSS.

The work material, its hardness, the machine tool used, part configuration, finish required on the components and volume of components to be produced are the few requirements that influence selection of different grades of HSS for manufacture of cutting tools.

Chemical composition of some grades of High Speed Steels normally used is given below:

HSS GRADES	CHEMICAL COMPOSITION					
	C	Cr	Mo	W	V	Co
M2	0.86/0.96	3.8/4.5	4.9/5.5	6.0/6.75	1.7/2.2	NIL
M35	0.88/0.96	3.8/4.5	4.9/5.5	6.0/6.75	1.7/2.2	4.5/5.2
M42	1.05/1.15	3.5/4.5	9.0/10.0	1.3/2.0	1.0/1.3	7.75/8.2
T42	1.25/1.35	3.5/4.5	3.2/4.0	9.5/10.7	2.8/3.5	9.7/10.2

C – Carbon
W – Tungsten

Cr – Chromium
Co – Cobalt

Mo – Molybdenum
V – Vanadium

TECHNICAL CALCULATIONS – DRILLING

$$\text{Cutting Speed } V_c = \frac{\pi DN}{1000}$$

D = Drill Diameter

N = Spindle speed in R.P.M.



TOLERANCES

NOMINAL DIMENSION RANGE		Value of Deviation in microns																		
Above	Upto	d9	e8	f7	h6	h8	h9	h11	h12	h13	js14	js16	k11	k12	m6	z9	H7	H8	H13	N11
	3	-20 -45	-14 -28	-7 -16	0 -7	0 -14	0 -25	0 -60	0 -90	0 -140	+125 -125	+300 -300	+60 0	+100 0	+9 +2	+53 +28	+9 0	+14 0	+140 0	0 -60
3	6	-30 -60	-20 -38	-10 -22	0 -8	0 -18	0 -30	0 -75	0 -120	0 -180	+150 -150	+375 -375	+75 0	+120 0	+12 +4	+53 +35	+12 0	+18 0	+180 0	0 -75
6	10	-40 -76	-25 -47	-13 -28	0 -9	0 -22	0 -36	0 -90	0 -150	0 -220	+180 -180	+450 -450	+90 0	+150 0	+15 +6	+78 +42	+15 0	+22 0	+220 0	0 -90
10	18	-50 -93	-32 -59	-16 -34	0 -11	0 -27	0 -43	0 -110	0 -180	0 -270	+215 -215	+550 -550	+110 0	+180 0	+18 +7	+120 +50	+18 0	+27 0	+270 0	0 -110
18	30	-65 -117	-40 -73	-20 -41	0 -13	0 -33	0 -52	0 -130	0 -210	0 -330	+260 -260	+650 -650	+130 0	+210 0	+21 +8	+157 +73	+21 0	+33 0	+330 0	0 -130
30	40	-80 -142	-50 -89	-25 -50	0 -16	0 -39	0 -62	0 -160	0 -250	0 -390	+310 -310	+800 -800	+160 0	+250 0	+25 +9	+174 +112	+25 0	+39 0	+390 0	0 -160
40	50	-80 -142	-50 -89	-25 -50	0 -16	0 -39	0 -62	0 -160	0 -250	0 -390	+310 -310	+800 -800	+160 0	+250 0	+25 +9	+198 +136	+25 0	+39 0	+390 0	0 -160
50	65	-100 -174	-60 -106	-30 -60	0 -19	0 -46	0 -74	0 -190	0 -300	0 -460	+370 -370	+950 -950	+190 0	+300 0	+30 +11	+245 +172	+30 0	+46 0	+460 0	0 -190
65	80	-100 -174	-60 -106	-30 -60	0 -19	0 -46	0 -74	0 -190	0 -300	0 -460	+370 -370	+950 -950	+190 0	+300 0	+30 +11	+284 +210	+30 0	+46 0	+460 0	0 -190
80	100	-120 -207	-72 -126	-36 -71	0 -22	0 -54	0 -87	0 -220	0 -350	0 -540	+435 -435	+1100 -1100	+220 0	+350 0	+35 +13	+345 +258	+35 0	+54 0	+540 0	0 -220
100	120	-120 -207	-72 -126	-36 -71	0 -22	0 -54	0 -87	0 -220	0 -350	0 -540	+435 -435	+1100 -1100	+220 0	+350 0	+35 +13	+397 +310	+35 0	+54 0	+540 0	0 -220
120	140	-145 -245	-85 -148	-43 -83	0 -25	0 -63	0 -100	0 -250	0 -400	0 -630	+500 -500	+1250 -1250	+250 0	+400 0	+40 +15	+465 +365	+40 0	+63 0	+630 0	0 -250
140	160	-145 -245	-85 -148	-43 -83	0 -25	0 -63	0 -100	0 -250	0 -400	0 -630	+500 -500	+1250 -1250	+250 0	+400 0	+40 +15	+515 +415	+40 0	+63 0	+630 0	0 -250
160	180	-145 -245	-85 -148	-43 -83	0 -25	0 -63	0 -100	0 -250	0 -400	0 -630	+500 -500	+1250 -1250	+250 0	+400 0	+40 +15	+565 +465	+40 0	+63 0	+630 0	0 -250
180	200	-170 -285	-100 -172	-50 -96	0 -29	0 -72	0 -115	0 -290	0 -460	0 -720	+575 -575	+1450 -1450	+290 0	+460 0	+46 +17	+635 +520	+46 0	+72 0	+720 0	0 -290
200	225	-170 -285	-100 -172	-50 -96	0 -29	0 -72	0 -115	0 -290	0 -460	0 -720	+575 -575	+1450 -1450	+290 0	+460 0	+46 +17		+46 0	+72 0	+720 0	0 -290
225	250	-170 -285	-100 -172	-50 -96	0 -29	0 -72	0 -115	0 -290	0 -460	0 -720	+575 -575	+1450 -1450	+290 0	+460 0	+46 +17		+46 0	+72 0	+720 0	0 -29

All values are in μ ($1\mu = 0.001$ mm)

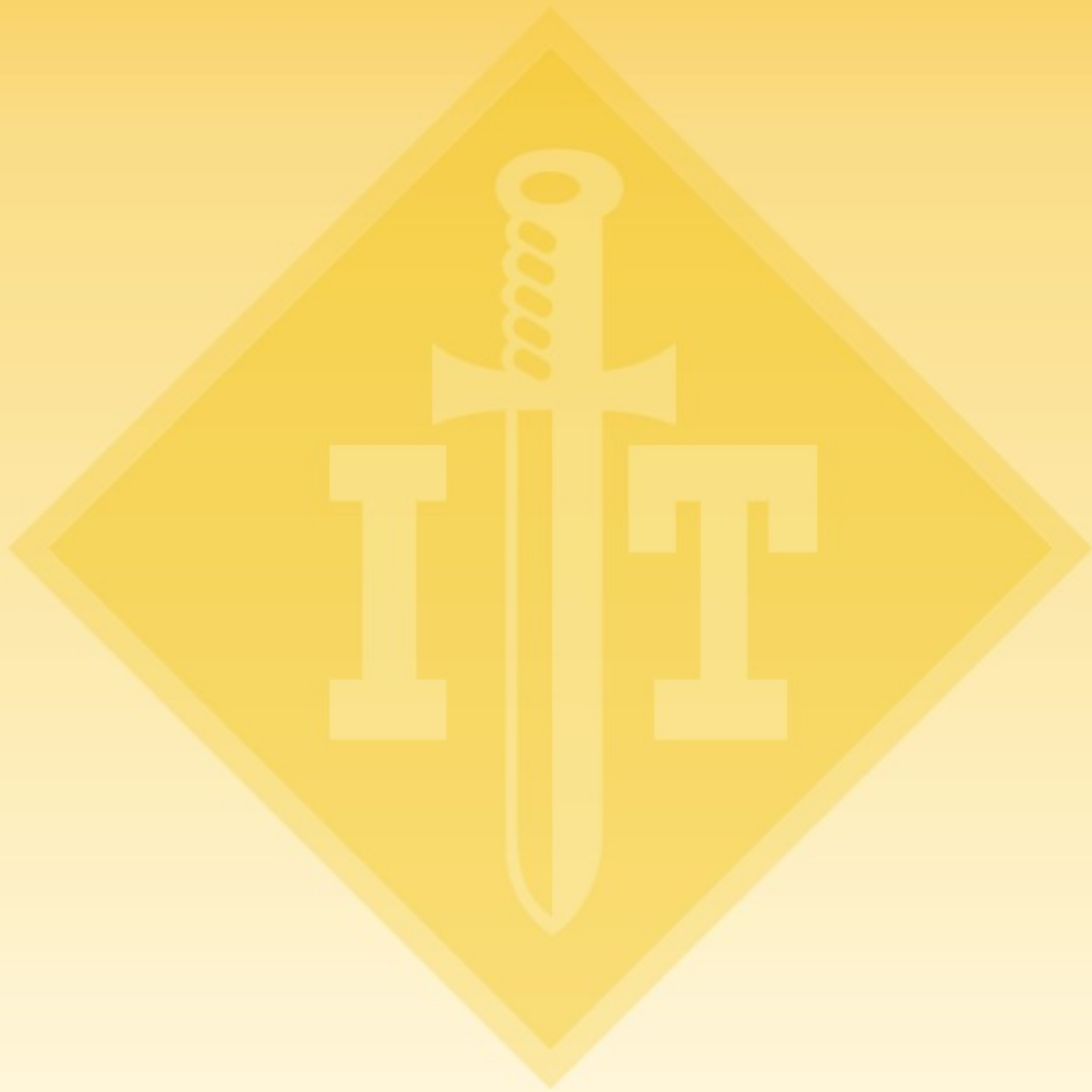

INDEX

PRODUCT	DESCRIPTION	Specification	Pg. No.
	Parallel Hand Reamers	IS 5444 : 2002 ISO 236/1 : 1976 BS 328 Part 4 : 1990 DIN 206 : 1979	76-78
	Long Fluted Machine Reamers	IS 5445 : 2002 ISO : 236/2 : 1976 BS : 328 Part 4 : 1990	79-80
	Parallel Machine Reamers	BS 328 Part 4 : 1990	81
	Machine Chucking Reamers with Parallel Shank	IS 5446 : 2002 ISO 521 : 1975 BS 328 Part 4 : 1990	82-83
	Machine Chucking Reamers with Taper Shank	IS 5447 : 2002 ISO 521 : 1975 BS 328 Part 4 : 1990	84-85
	Machine Jig Reamers with Taper Shank	Dimensions are in mm Specifications conform to: IS 11002 : 1999	86
	Shell Reamers	IS 5926 : 2002 ISO 2402 : 1976 DIN 219 : 1981 (Type A) BS 328 Part 4 : 1990	87-89
	Socket Reamers with Parallel Shank	IS 5882 : 2002 ISO 2250 : 1972 BS 328 Part 4 : 1990	90
	Socket Reamers with Taper Shank	IS 5907 : 2002 BS 328 Part 4 : 1990	91
	Taper Pin Hand Reamers	IS 5881 : 1999 ISO 3465 : 1975 BS 328 Part 4 : 1990 DIN 9 : 1975 BS 122 Part 2 : 1964	92-93
	Taper Pin Machine Reamers	IS 5918 : 1999 ISO 3467 : 1975 BS 328 Part 4 : 1990 DIN 2180 : 1975 BS 122 Part 2 : 1964	94-95
	Machine Bridge Reamers	IS 5919 : 2002 ISO 2238 : 1972 BS 328 Part 4 : 1990 BS 122 Part 2 : 1964	96-97
	Hole Mills-Unguided Type 'A' (Roughing)	IS 5989 : 2002	98
	Hole Mills-guided Type 'B' (Roughing / Finishing)	IS 5989 : 2002	99
	Taper Pipe Reamers	ASA B 94.2 : 1964	100
	Technical Section		101-105



REAMERS

Experttoolings.com





Elements of a Reamer and Related terms

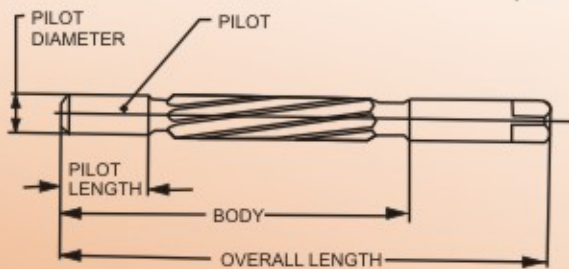
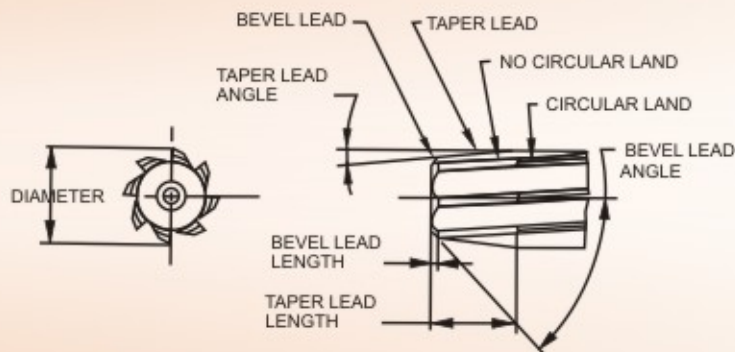
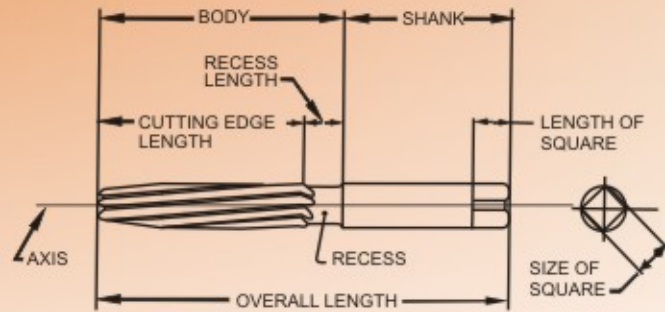

Terms Relating to Cutting Geometry of Reamers

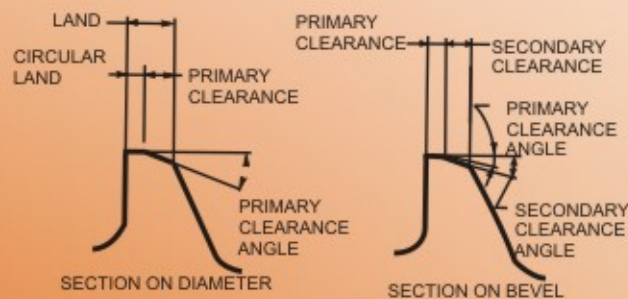

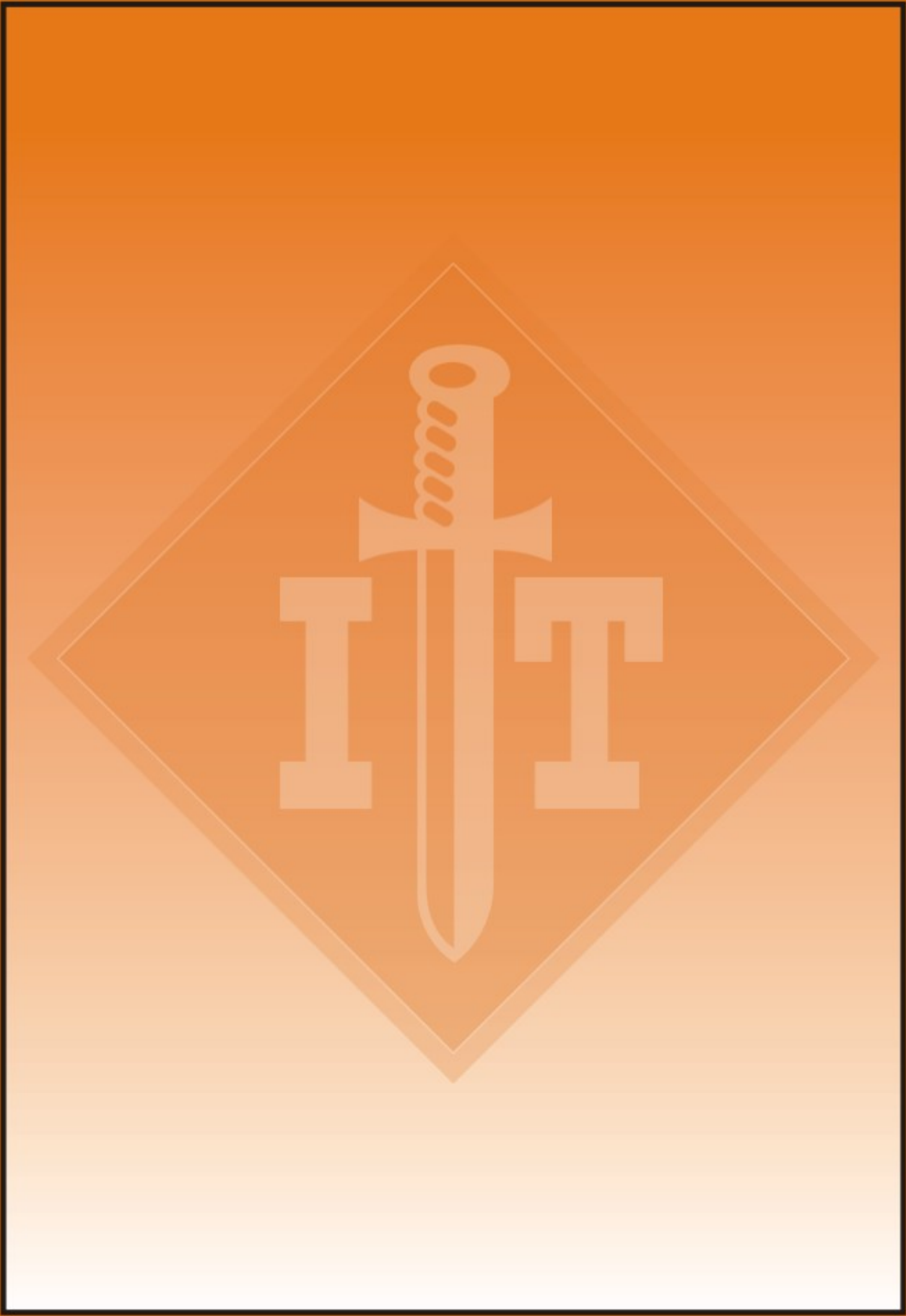



REAMERS



Dimensions in mm
 Specifications conform to:
 IS 5444 : 2002
 ISO 236/1 : 1976
 BS 328 Part 4 : 1990
 DIN 206 : 1979

76

High Speed Steel PARALLEL HAND REAMERS

Nominal Diameter (m6)	Cutting edge length	Overall length	Shank dia (h9)	Square	
				Size (h11)	Length
3.00	31	62	3.00	-	-
3.20	33	66	3.20	2.50	5.0
3.50	35	71	3.50	2.80	5.0
4.00	38	76	4.00	3.15	6.0
4.50	41	81	4.50	3.55	6.0
5.00	44	87	5.00	4.00	7.0
5.50	47	93	5.50	4.50	7.0
6.00	47	93	6.00	4.50	7.0
6.50	50	100	6.50	5.00	8.0
7.00	54	107	7.00	5.60	8.0
8.00	58	115	8.00	6.3	9.0
9.00	62	124	9.00	7.10	10.0
10.00	66	133	10.00	8.00	11.0
11.00	71	142	11.00	9.00	12.0
12.00	76	152	12.00	10.00	13.0
13.00	76	152	13.00	10.00	13.0
14.00	81	163	14.00	11.20	14.0
15.00	81	163	15.00	11.20	14.0
16.00	87	175	16.00	12.50	16.0
17.00	87	175	17.00	12.50	16.0
18.00	93	188	18.00	14.00	18.0
19.00	93	188	19.00	14.00	18.0
20.00	100	201	20.00	16.00	20.0
21.00	100	201	21.00	16.00	20.0
22.00	107	215	22.00	18.00	22.0
23.00	107	215	23.00	18.00	22.0
24.00	115	231	24.00	20.00	24.0
25.00	115	231	25.00	20.00	24.0
26.00	115	231	26.00	20.00	24.0
27.00	124	247	27.00	22.40	26.0
28.00	124	247	28.00	22.40	26.0
30.00	124	247	30.00	22.40	26.0
32.00	133	265	32.00	25.00	28.0
34.00	142	284	34.00	28.00	31.0
35.00	142	284	35.00	28.00	31.0
36.00	142	284	36.00	28.00	31.0
38.00	152	305	38.00	31.50	34.0
40.00	152	305	40.00	31.50	34.0
42.00	152	305	42.00	31.50	34.0
44.00	163	326	44.00	35.50	38.0
45.00	163	326	45.00	35.50	38.0
46.00	163	326	46.00	35.50	38.0
48.00	174	347	48.00	40.00	42.0
50.00	174	347	50.00	40.00	42.0
52.00	174	347	52.00	40.00	42.0
55.00	184	367	55.00	45.00	42.0
56.00	184	367	56.00	45.00	46.0

These reamers have LH helical flutes for RH cutting.

Range of Application:
 For use in General Hand Reaming

**High Speed Steel
PARALLEL HAND REAMERS**



Nominal Diameter m6	Cutting edge length	Overall length	Shank Dia (h9)	Square	
				Size (h11)	Length
58.00	184	367	58	45	46
60.00	184	367	60	45	46
62.00	194	387	62	50	51
63.00	194	387	63	50	51
67.00	194	287	67	50	51
71.00	203	406	71	56	56

These reamers have LH helical flutes for RH cutting

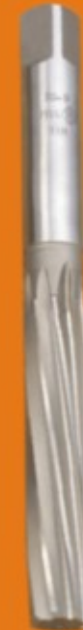

REAMERS

Dimensions in mm
Specifications conform to:
IS 5444 : 2002
ISO 236/1 : 1976
BS 328 Part 4 : 1990
DIN 206 : 1979

Range of Application:
For use in General Hand Reaming



REAMERS



High Speed Steel PARALLEL HAND REAMERS

Nominal Diameter (m6)	Cutting edge length	Overall length	Square	
			Size (h11)	Length
1/8	33	66	2.50	5.0
5/32	38	76	3.15	6.0
3/16	44	87	4.00	7.0
7/32	47	93	4.50	7.0
1/4	50	100	5.0	8.0
9/32	54	107	5.60	8.00
5/16	58	115	6.30	9.00
11/32	62	124	7.10	10.00
3/8	66	133	8.00	11.00
7/16	71	142	9.00	12.00
15/32	76	152	10.00	13.00
1/2	76	152	10.00	13.00
9/16	81	163	11.20	14.00
5/8	87	175	12.90	16.00
11/16	93	188	14.00	18.00
3/4	100	201	16.00	18.00
13/16	100	201	16.00	20.00
7/8	107	215	18.00	22.00
15/16	115	231	20.00	24.00
1	115	231	20.00	24.00
1.1/16	124	247	22.40	26.00
1.1/8	124	247	22.40	26.00
1.3/16	133	265	25.00	28.00
1.1/4	133	265	25.00	28.00
1.5/16	133	265	25.00	28.00
1.3/8	142	284	28.00	31.00
1.7/16	142	284	28.00	31.00
1.1/2	152	305	31.50	34.00
1.5/8	152	305	31.50	34.00
1.3/4	163	326	35.5	38.00
1.7/8	174	347	40.00	42.00
2	174	347	40.00	42.00

These reamers have LH helical flutes for RH cutting.

Dimensions in inch / mm
Specifications conform to:
BS 328 Part 4 : 1990

**High Speed Steel
LONG FLUTED MACHINE REAMERS**



Nominal Diameter (m6)	Cutting edge length	Overall length	MT Shank no
3.00	31	111	1
3.20	33	113	1
3.50	35	115	1
4.00	38	118	1
4.50	41	121	1
5.00	44	124	1
6.00	47	127	1
6.50	50	130	1
7.00	54	134	1
8.00	58	138	1
9.00	64	142	1
10.00	66	146	1
11.00	71	151	1
12.00	76	156	1
13.00	76	156	1
14.00	81	161	1
15.00	81	181	2
16.00	87	187	2
17.00	87	187	2
18.00	93	193	2
19.00	93	193	2
20.00	100	200	2
21.00	100	200	2
22.00	107	207	2
23.00	107	207	2
23.50	107	234	3
24.00	115	242	3
25.00	115	242	3
26.00	115	242	3
27.00	124	251	3
28.00	124	251	3
30.00	124	251	3
31.75	133	260	3
32.00	133	293	4
34.00	142	302	4
35.00	142	302	4
36.00	142	302	4
38.00	152	312	4
40.00	152	312	4
42.00	152	312	4
44.00	163	323	4
45.00	163	323	4
46.00	163	323	4
48.00	174	334	4
50.00	174	334	4
52.00	174	371	5
55.00	184	381	5



REAMERS

Dimensions in mm
Specifications conform to:
IS 5445 : 2002
ISO : 236/2 : 1976
BS : 328 Part 4 : 1990

These reamers have LH helical flutes for RH Cutting

Range of Application :
For use in General Machine Reaming



REAMERS



Dimensions in mm
Specifications conform to:
IS 5445 : 2002
ISO 236/2 : 1976
BS 328 Part 4 :1990

High Speed Steel LONG FLUTED MACHINE REAMERS

Nominal Diameter(m6)	Cutting edge length	Overall length	MT Shank no
56.00	184	381	5
58.00	184	381	5
60.00	184	381	5
62.00	194	391	5
63.00	194	391	5
67.00	194	391	5
71.00	203	400	5
72.00	203	400	5
73.00	203	400	5
74.00	203	400	5
75.00	203	400	5

These reamers have LH helical flutes for RH Cutting

**High Speed Steel
PARALLEL MACHINE REAMERS**



Nominal Diameter(m6)	Cutting edge length	Overall length	MT Shank no
1/8	33	113	1
5/32	38	118	1
3/16	44	124	1
1/4	50	130	1
9/32	54	134	1
5/16	58	138	1
11/32	62	142	1
3/8	66	146	1
13/32	66	146	1
7/16	71	151	1
15/32	76	156	1
1/2	76	156	1
9/16	81	181	2
5/8	87	187	2
11/16	93	193	2
3/4	100	200	2
13/16	100	200	2
7/8	107	207	2
15/16	115	242	3
1	115	242	3
1.1/16	124	251	3
1.1/8	124	251	3
1.3/16	133	260	3
1.1/4	133	260	3
1.5/16	133	293	4
1.3/8	142	302	4
1.7/16	142	302	4
1.1/2	152	312	4
1.5/8	152	312	4
1.3/4	163	323	4
1.7/8	174	334	4
2	174	334	4
2.1/4	184	381	5
2.1/2	194	391	5
3	212	409	5

These reamers have LH helical flutes for RH Cutting



REAMERS

Dimensions in inch/mm
Specifications conform to:
BS 328 Part 4 : 1990

Range of Application:
For General Machine Reaming



REAMERS



Dimensions in mm
Specifications conform to:
IS 5446 : 2002
ISO 521 : 1975
BS 328 Part 4 : 1990

High Speed Steel MACHINE CHUCKING REAMERS WITH PARALLEL SHANK

Nominal Diameter (m6)	Cutting edge length	Overall length	Shank Dia. (h9)
3.00	15	61	3.00
3.20	16	65	3.20
3.50	18	70	3.50
4.00	19	75	4.00
4.50	21	80	4.50
5.00	23	86	5.00
5.50	26	93	5.60
6.00	26	93	5.60
6.50	28	101	6.30
7.00	31	109	7.10
8.00	33	117	8.00
9.00	36	125	9.00
10.00	38	133	10.00
11.00	41	142	10.00
12.00	44	151	10.00
13.00	44	151	10.00
14.00	47	160	12.50
15.00	50	162	12.50
16.00	52	170	12.50
17.00	54	175	14.00
18.00	56	182	14.00
19.00	58	189	16.00
20.00	60	195	16.00

These reamers have Straight flutes for RH Cutting

**High Speed Steel
MACHINE CHUCKING REAMERS WITH
PARALLEL SHANK**



Nominal Diameter (inch) (M6)	Cutting edge length	Overall length	Shank Dia. (Inch)
1/8	16	65	0.0984
5/32	19	75	0.1240
3/16	23	86	0.1575
7/32	26	93	0.1968
1/4	28	101	0.1968
9/32	31	109	0.2480
5/16	33	117	0.2480
11/32	36	125	0.3150
3/8	38	133	0.3150
13/32	38	133	0.3150
7/16	41	142	0.3937
15/32	44	151	0.3937
1/2	44	151	0.3937
9/16	50	162	0.4921
5/8	52	170	0.4921

These reamers have straight flutes for RH Cutting



REAMERS

Dimensions inch/mm
Specifications conform to:
BS 328 Part 4 : 1990

Range of Application:
For use in General Machine Reaming



REAMERS



Dimensions in mm
Specifications conform to:
IS 5447 : 2002
ISO 521 : 1975
BS 328 Part 4 : 1990

High Speed Steel MACHINE CHUCKING REAMERS WITH TAPER SHANK

Nominal Diameter (m6)	Cutting edge length	Overall length	MT Shank no
3.00	15	122	1
3.20	16	124	1
3.50	18	126	1
4.00	19	128	1
4.50	21	130	1
5.00	23	133	1
5.50	26	138	1
6.00	26	138	1
6.50	28	144	1
7.00	31	150	1
8.00	33	156	1
9.00	36	162	1
10.00	38	168	1
11.00	41	175	1
12.00	44	182	1
13.00	44	182	1
14.00	47	189	1
15.00	50	204	2
16.00	52	210	2
17.00	54	214	2
18.00	56	219	2
19.00	58	223	2
20.00	60	228	2
21.00	62	232	2
22.00	64	237	2
23.00	66	241	2
23.50	66	264	3
24.00	68	268	3
25.00	68	268	3
26.00	70	273	3
28.00	71	277	3
30.00	73	281	3
31.00	75	285	3
31.75	77	290	3
32.00	77	317	4
34.00	78	321	4
35.00	78	321	4
36.00	79	325	4
38.00	81	329	4
40.00	81	329	4
42.00	82	333	4
44.00	83	336	4
45.00	83	336	4
46.00	84	340	4
48.00	86	344	4
50.00	86	344	4

These reamers have straight flutes for RH Cutting

Range of Application:
For use in General Machine Reaming

**High Speed Steel
MACHINE CHUCKING REAMERS WITH
TAPER SHANK**



Nominal Diameter (m6)	Cutting edge length	Overall length	MT Shan No.
5/32	19	128	1
3/16	23	133	1
1/4	28	144	1
5/16	33	152	1
3/8	38	168	1
7/16	41	175	1
1/2	44	182	1
9/16	50	204	2
5/8	52	210	2
11/16	56	219	2
3/4	60	228	2
13/16	62	232	2
7/8	64	237	2
15/16	68	268	3
1	70	273	3
1.1/16	71	277	3
1.1/8	73	281	3
1.3/16	75	285	3
1.1/4	77	290	3
1.5/16	77	317	4
1.3/8	78	321	4
1.7/16	79	325	4
1.1/2	81	329	4
1.5/8	82	333	4
1.3/4	83	336	4
2	86	344	4

These reamers have straight flutes for RH Cutting



REAMERS

Dimensions in mm
Specifications conform to:
BS 328 Part 4 : 1990

Range of Application:
For use in General Machine Reaming



REAMERS



High Speed Steel MACHINE JIG REAMERS WITH TAPER SHANK

Nominal Diameter (m6)	Cutting edge length	Overall length	MT Shank No.
6.00	26	138	1
6.50	28	144	1
7.00	31	150	1
8.00	33	156	1
9.00	36	162	1
10.00	38	168	1
11.00	41	175	1
12.00	44	182	1
13.00	44	182	1
14.00	47	189	1
15.00	50	204	2
16.00	52	210	2
17.00	54	214	2
18.00	56	219	2
19.00	58	223	2
20.00	60	228	2
21.00	62	232	2
22.00	64	237	2
23.00	66	241	2
23.50	66	264	3
24.00	68	268	3
25.00	68	268	3
26.00	70	273	3
28.00	71	277	3
30.00	73	281	3
31.00	75	285	3
31.75	77	290	3
32.00	77	317	4
34.00	78	321	4
35.00	78	321	4
36.00	79	325	4
38.00	81	329	4
40.00	81	329	4
42.00	82	333	4
44.00	83	336	4
45.00	83	336	4
46.00	84	340	4
48.00	86	344	4
50.00	86	344	4

These reamers have LH helical flutes for RH Cutting

Dimensions in mm
Specifications conform to:
IS 11002 : 1999

**High Speed Steel
SHELL REAMERS
With Taper Bore - 1:30**



Nominal Diameter(m6)	Large end Dia of Taper bore	Cutting Edge Length	Overall length
21	10	28	40
22	10	28	40
23	10	28	40
24	13	32	45
25	13	32	45
26	13	32	45
27	13	32	45
28	13	32	45
29	13	32	45
30	13	32	45
31	16	36	50
32	16	36	50
33	16	36	50
34	16	36	50
35	16	36	50
36	19	40	56
37	19	40	56
38	19	40	56
39	19	40	56
40	19	40	56
41	19	40	56
42	19	40	56
43	22	45	63
44	22	45	63
45	22	45	63
46	22	45	63
47	22	45	63
48	22	45	63
49	22	45	63
50	22	45	63
51	27	50	71
52	27	50	71
53	27	50	71
54	27	50	71
55	27	50	71
56	27	50	71
57	27	50	71
58	27	50	71
59	27	50	71
60	27	50	71
61	32	56	80
62	32	56	80
63	32	56	80

These reamers have straight flutes for RH cutting with slot drive

Range of Application:

For use in General Machine Reaming.
Common arbors can be used with different diameter of these reamers



REAMERS

Dimensions in mm
Specifications conform to:
IS 5926 : 2002
ISO 2402 : 1976
DIN 219 : 1981 (Type A)



REAMERS



Dimensions in mm
 Specifications conform to:
 IS 5926 : 2002
 ISO 2402 : 1976
 DIN 219 : 1981 (Type A)

High Speed Steel SHELL REAMERS With Taper Bore - 1:30

Nominal Diameter (m6)	Large end Dia of Taper bore	Cutting Edge Length	Overall length
64	32	56	80
65	32	56	80
66	32	56	80
67	32	56	80
68	32	56	80
69	32	56	80
70	32	56	80
71	32	56	80
72	40	63	90
73	40	63	90
74	40	63	90
75	40	63	90
76	40	63	90
77	40	63	90
78	40	63	90
79	40	63	90
80	40	63	90
81	40	63	90
82	40	63	90
83	40	63	90
84	40	63	90
85	40	63	90
86	50	71	90
87	50	71	100
88	50	71	100
89	50	71	100
90	50	71	100
91	50	71	100
92	50	71	100
93	50	71	100
94	50	71	100
95	50	71	100
96	50	71	100
97	50	71	100
98	50	71	100
99	50	71	100
100	50	71	100

These reamers have straight flutes for RH cutting with slot drive

Range of Application:

For use in General Machine Reaming.
 Common arbors can be used with different diameter of these reamers

**High Speed Steel
SHEEL REAMERS**
With Taper Bore - 1/8" taper per foot on dia



Nominal Diameter m6	Large end Dia of Taper bore	Cutting Edge Length	Overall length
1	0.625	2.1/4	2.3/4
1.1/16	0.625	2.1/4	2.3/4
1.1/8	0.625	2.1/4	2.3/4
1.3/16	0.625	2.1/4	2.3/4
1.1/4	0.625	2.1/4	2.3/4
1.5/16	0.750	2.3/8	3
1.3/8	0.750	2.3/8	3
1.7/16	0.750	2.3/8	3
1.1/2	0.750	2.3/8	3
1.9/16	0.750	2.3/8	3
1.5/8	0.750	2.3/8	3
1.11/16	1.000	2.3/4	3.1/2
1.3/4	1.000	2.3/4	3.1/2
1.13/16	1.000	2.3/4	3.1/2
1.7/8	1.000	2.3/4	3.1/2
1.15/16	1.000	2.3/4	3.1/2
2	1.000	2.3/4	3.1/2
2.1/16	1.250	3	3.3/4
2.1/8	1.250	3	3.3/4
2.3/16	1.250	3	3.3/4
2.1/4	1.250	3	3.3/4
2.5/16	1.250	3	3.3/4
2.3/8	1.250	3	3.3/4
2.7/16	1.250	3	3.3/4
2.1/2	1.500	3	4
2.5/8	1.500	3.1/4	4
2.3/4	1.500	3.1/4	4
2.7/8	1.500	3.1/4	4
3	1.500	3.1/4	4
3.1/8	1.750	3.3/4	4.1/2
3.1/4	1.750	3.3/4	4.1/2
3.3/8	1.750	3.3/4	4.1/2
3.1/2	1.750	3.3/4	4.1/2
3.5/8	2.000	4.1/4	5
3.3/4	2.000	4.1/4	5
3.7/8	2.000	4.1/4	5
4	2.000	4.1/4	5

These reamers have left hand helical flutes for RH cutting with slot drive

Range of Application:

For use in General Machine Reaming.
Common arbors can be used with different diameter of these reamers



REAMERS

Dimensions in inches
Specifications conform to:
BS 328 Part 4 : 1990



High Speed Steel SOCKET REAMERS WITH PARALLEL SHANK

Morse Taper no	Cutting edge length	Overall length	Dia of Shank (h9)	Square	
				Size	Length
0	61	98	8	6.3	9
1	66	102	10	8.0	11
2	79	121	14	11.2	14
3	96	146	20	16	20
4	119	179	25	20	24
5	150	222	31.5	25	28
6	208	300	45	35.5	38

These reamers have
Type A roughing - RH helical flutes for RH cutting
Type B pre finishing - Straight flutes for RH cutting
Type C finishing - LH helical flutes for RH cutting



REAMERS

Dimensions in mm
Specifications conform to:
IS 5882 : 2002
ISO 2250 : 1972
BS 328 Part 4 : 1990

90

Range of Application:
For use in Reaming morse taper holes

**High Speed Steel
SOCKET REAMERS WITH TAPER SHANK**



Morse Taper no	Cutting Edge Length	Overall Length	MT Shank No
0	61	137	1
1	66	142	1
2	79	173	2
3	96	212	3
4	119	263	4
5	150	331	5
6	208	389	5

These reamers have
Type A roughing - RH helical flutes for RH cutting
Type B pre finishing - Straight flutes for RH cutting
Type C finishing - LH helical flutes for RH cutting



REAMERS

Dimensions in mm
Specifications conform to:
IS 5907 : 2002
BS 328 Part 4 : 1990

Range of Application:
For use in Reaming morse taper holes



REAMERS



Dimensions in inches
Specifications conform to:
IS 5881 : 1999
ISO 3465 : 1975
BS 328 Part 4 : 1990
DIN 9 : 1975

High Speed Steel TAPER PIN HAND REAMERS Taper - 1:50 on Dia

Nominal Diameter	Cutting Edge Length	Overall length	Shank Dia	Square	
			(h11)	Size (h11)	Length
3	58	80	4	3.15	6
4	68	93	5	4	7
5	73	100	6.3	5	8
6	105	135	8	6.3	9
8	145	180	10	8	11
10	175	215	12.5	10	13
12	210	255	14	11.2	14
16	230	280	18	14	18
20	250	310	22.4	18	22
25	300	370	28	22.4	26
30	320	400	31.5	25	28
40	340	430	40	31.5	34
50	360	460	50	40	42

These reamers have
Type A Straight flutes for RH cutting
Type B LH Helical for RH cutting

**High Speed Steel
TAPER PIN HAND REAMERS
Taper 1:48 on Dia**



Nominal Diameter	Large end dia	Small end dia	Cutting edge length	Overall Length
1/8	0.127	0.0905	1.3/4	2.3/4
5/32	0.1580	0.1163	2	3
3/16	0.1950	0.1377	2.3/4	4
7/32	0.2200	0.1627	2.3/4	4
1/4	0.2530	0.1827	3.3/8	4.5/8
9/32	0.292	0.2061	4.1/8	5.5/8
5/16	0.3160	0.2301	4.1/8	5.5/8
11/32	0.3470	0.2533	4.1/2	6
3/8	0.3810	0.2768	5	6.1/2
13/32	0.4120	0.2922	5.3/4	7.1/2
7/16	0.4430	0.3232	5.3/4	7.1/2
1/2	0.5060	0.3706	6.1/2	8.1/4
9/16	0.5710	0.4304	6.3/4	8.1/2
5/8	0.6330	0.4768	7.1/2	9.1/4
3/4	0.7600	0.5777	8.3/4	10.3/4
7/8	0.885	0.6871	9.1/2	12

These reamers have straight flutes RH cutting



REAMERS

Dimensions in inches
Specifications conform to:
BS 122 Part 2 : 1964

Range of Application:
For use in Reaming holes suitable for standard taper pins



REAMERS



Dimensions in mm
Specifications conform to:
IS 5918 : 1999
ISO 3467 : 1975
BS 328 Part4 :1990
DIN 2180 :1975

High Speed Steel TAPER PIN MACHINE REAMERS Taper 1:50

Nominal Diameter	Cutting Edge Length	Overall Length	MT Shank no
3	58	140	1
4	68	150	1
5	73	155	1
6	105	187	1
8	145	227	1
10	175	257	1
12	210	315	2
16	230	335	2
20	250	377	3
25	300	427	3
30	320	475	4
40	340	495	4
50	360	550	5

These reamers have LH helical flutes for RH cutting

**High Speed Steel
TAPER PIN MACHINE REAMERS
TAPER 1 : 48**



Nominal Diameter	Large end dia	Small end dia	Cutting edge length	Overall Length	MT Shank no
3/16	0.1950	0.1377	3.1/8	6.1/16	1
7/32	0.2200	0.1627	3.3/16	6.1/8	1
1/4	0.2530	0.1827	3.7/8	6.13/16	1
9/32	0.2920	0.2061	4.5/8	7.5/8	1
5/16	0.3160	0.2301	4.5/8	7.5/8	1
11/32	0.3470	0.2533	5.3/32	8.3/32	1
3/8	0.3810	0.2768	5.13/16	8.7/8	1
13/32	0.4120	0.2922	6.9/16	9.5/8	1
7/16	0.4430	0.3232	6.11/16	9.3/4	1
1/2	0.5060	0.3706	7.7/16	10.1/2	1
9/16	0.5710	0.4304	7.3/4	1.1/2	2
5/8	0.633	0.4768	8.1/2	2.1/4	2
3/4	0.7600	0.5777	9.3/4	3.1/2	2
7/8	0.885	0.6871	10.1/2	4.1/4	2

These reamers have straight flutes for RH cutting



REAMERS

Dimensions in inches
Specifications conform to:
BS 122 Part 2 : 1964

Range of Application:
For use in machine reaming holes suitable for standard taper pins.



REAMERS



Dimensions in mm
Specifications conform to:
IS 5919 : 2002
ISO 2238 : 1972
BS 328 Part-4 : 1990

High Speed Steel MACHINE BRIDGE REAMERS

Nominal Diameter (k11)	Cutting edge	Overall Length	MT Shank no
6.40	75	151	1
7.40	80	156	1
8.40	85	161	1
9.50	90	166	1
10.00	95	171	1
11.00	100	176	1
13.00	105	199	2
14.00	115	209	2
15.00	125	219	2
16.00	135	229	2
17.00	135	251	3
19.00	145	261	3
21.00	155	271	3
23.00	165	281	3
25.00	180	296	3
28.00	195	311	3
31.00	210	326	3
32.00	210	354	4
34.00	220	364	4
37.00	220	364	4
40.00	230	374	4
43.00	240	384	4
49.00	250	394	4

These reamers have 25° LH helical flutes for RH cutting.

**High Speed Steel
MACHINE BRIDGE REAMERS**



Nominal Diameter	Cutting edge length	Overall Length	Diameter small end of taper	MT Shank no
1/4	3.3/8	6.3/8	1/8	1
5/16	3.3/4	6.3/4	3/16	1
3/8	4	7	7/32	1
7/16	4.3/8	8.1/8	1/4	2
1/2	5.3/8	9.1/8	9/32	2
9/16	5.3/8	9.1/8	5/16	2
5/8	6.1/8	9.7/8	11/32	2
11/16	6.1/8	9.7/8	3/8	2
11/16	7.1/8	11.3/4	3/8	3
3/4	7.3/8	12	7/16	3
13/16	7.3/8	12	1/2	3
7/8	7.3/8	12	9/16	3
15/16	7.3/8	12	5/8	3
1	7.3/8	12	11/16	3
1.1/16	7.3/8	12	3/4	3
1.1/8	7.3/8	12	13/16	3
1.3/16	7.3/8	12	7/8	3
1.1/4	7.3/8	12	15/16	3
1.1/4	7.3/8	13	15/16	4
1.5/16	7.3/8	13	1	4
1.3/8	7.3/8	13	1.1/16	4
1.7/16	7.3/8	13	1.1/8	4
1.1/2	7.3/8	13	1.3/16	4
1.9/16	8.3/8	14	1.1/4	4
1.5/8	8.3/8	14	1.5/16	4
1.11/16	8.3/8	14	1.3/8	4
1.3/4	8.3/8	14	1.7/16	4
1.13/16	8.3/8	14	1.1/2	4
1.7/8	8.3/8	14	1.9/16	4
1.15/16	8.3/8	14	1.5/8	4
2	8.3/8	14	1.11/16	4

These Reamers have LH helical flutes for RH cutting



REAMERS

Dimensions in inch
Specifications conform to:
BS 122 Part 2 : 1964

Range of Application:

For use in opening out predrilled hole for alignment in structural steel work

**High Speed Steel
HOLE MILLS GUIDED -
TYPE B (Roughing / Finishing)**



Nominal Roughing (h6)	Diameter Finishing (m6)	Cutting edge length	Overall Length	MT Shank no
4.9	5	25	150	1
5.9	6	25	150	1
7.9	8	25	170	1
9.9	10	30	180	1
11.8	12	35	190	1
12.8	13	35	200	1
13.8	14	35	200	1
14.8	15	35	210	2
15.8	16	40	230	2
17.8	18	45	235	2
19.8	20	45	245	2
21.7	22	45	255	2
23.7	24	55	290	3
24.7	25	55	290	3
25.7	26	60	305	3
26.7	27	60	305	3
27.7	28	60	305	3
29.7	30	60	320	3
31.7	32	60	320	3
33.7	34	60	360	4
34.7	35	60	360	4
35.7	36	60	360	4
37.7	38	60	390	4
39.7	40	60	390	4
41.6	42	60	390	4

These hole mills have RH helical flutes for RH cutting

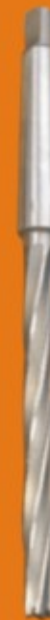

REAMERS

Dimensions in mm
Specifications conform to:
IS 5989 : 2002

Range of Application:
For use in opening out predrilled holes with flat bottom



REAMERS



Dimensions in inch
Specifications conform to:
ASA B 94.2 : 1964

High Speed Steel TAPER PIPE REAMERS

Nominal Size	Large end dia	Small end dia	Cutting Edge Length	Overall Length
1/8	0.362	0.316	3/4	2.1/8
1/4	0.472	0.406	1.1/16	2.9/16
3/8	0.606	0.540	1.1/16	2.9/16
1/2	0.751	0.665	1.3/8	3.1/8
3/4	0.962	0.876	1.3/8	3.1/8
1	1.212	1.103	1.3/4	3.3/4
1.1/4	1.533	1.444	1.3/4	4
1.1/2	1.793	1.684	1.3/4	4.1/4
2	2.268	2.159	1.3/4	4.1/2

These reamers have LH helical flutes for RH cutting
Taper 3/4 inch per foot

Range of Application:

Used prior to tapping with taper pipe taps when tapping
Dryseal NPTF and military aeronautical thread ANPT



TECHNICAL SUPPLY CONDITIONS OF "DAGGER REAMERS"

1. Reamers are normally supplied with straight flutes or helical flutes for RH cutting.
2. Intermediate diameters, if ordered, shall be supplied with the same dimensions as the next larger standard size.
3. Non standard or special reamers are manufactured against specific orders.
4. Morse taper Shank dimensions are according to IS: 1715 – Dimensions for self-holding tapers.
- 4.1 Driving square according to IS: 1850 – Dimensions for shank diameters and driving squares for rotating tools.
5. Other general requirements are maintained according to IS: 5443 – Technical supply conditions for high speed steel reamers.

- 5.1 Hardness :
- Cutting portion : 760 HV to 900 HV.
- Shank portion : 240 HV to Maximum hardness equal to cutting portion
(in case of one piece construction)
185 HV to 450 HV (in case of two piece construction)
- Tang of Morse Taper : Sizes below 10 mm 185 HV minimum and for sizes
10mm and above 300 HV to 450 HV
- Driving tenon : 240 HV to maximum hardness equal to cutting portion.

5.2 Reamers are normally supplied with m6 tolerance on cutting portion and are expected to produce H8 holes; by selection will also be suitable for H7 holes.

- 5.3 Run out tolerance:
Run out tolerances are usually maintained for standard reamer as shown in the table below.

RUN OUT TOLERANCES

Reamer diameter		Shell Reamers and Machine Reamers with Parallel Shank / Taper shank			Hand reamer
Over	Up to & Including	On Bevel edge	On Diameter	On Shank diameter	On Taper lead
1	3	0.020	0.005	0.010	0.030
3	6	0.020	0.006	0.012	0.030
6	10	0.025	0.008	0.015	0.030
10	18	0.025	0.008	0.018	0.036
18	30	0.030	0.009	0.021	0.042
30	50	0.030	0.011	0.025	0.050
50	80	0.040	0.013	0.030	0.060
80	120	0.040	0.015		

5.4 Reamers shall have a black taper at the rate of 0.010 to 0.020 per 100 mm cutting edge length up to 30 mm diameter and 0.020 to 0.030 per 100 mm for sizes above 30 mm diameter

6.0 Reamers according to DIN, BS and ANS are also manufactured against specific orders.



TOLERANCE FOR SPECIAL REAMERS

Ref: IS 5443 – 1994

GENERAL

Unless otherwise specified, the diameter of the cutting portion of the reamer shall have a tolerance of m6. For determining the tolerance for the diameter of the cutting portion of the reamers where of the cutting portion of the reamers where a grade of accuracy other than m6 is required. It is impossible to infer in advance the tolerance of a hole produced by a particular reamer because the actual diameter produced by the reamer depends upon a number of factors. Some of the factors which influence the accuracy of the hole diameter are as follows :

- Type and amount of the material to be removed.
- Cutting edge design of the reamer.
- Method of mounting and operation.
- Condition of the reamer at the time of use, and
- Lubrication

These factors shall be taken into account while determining the special tolerance to be given on a reamer in order to get a hole of given tolerance.

METHOD OF DETERMINING THE SPECIAL TOLERANCE

The maximum limit for the reamer diameter = the maximum limit of the hole – 0.15 IT.

The value of 0.15 IT is to be rounded to next higher value of 0.001 mm.

The minimum limit of the reamer diameter = the maximum limit of the reamer – 0.35 IT

The value of 0.35 IT is to be rounded to next higher value of 0.001 mm.

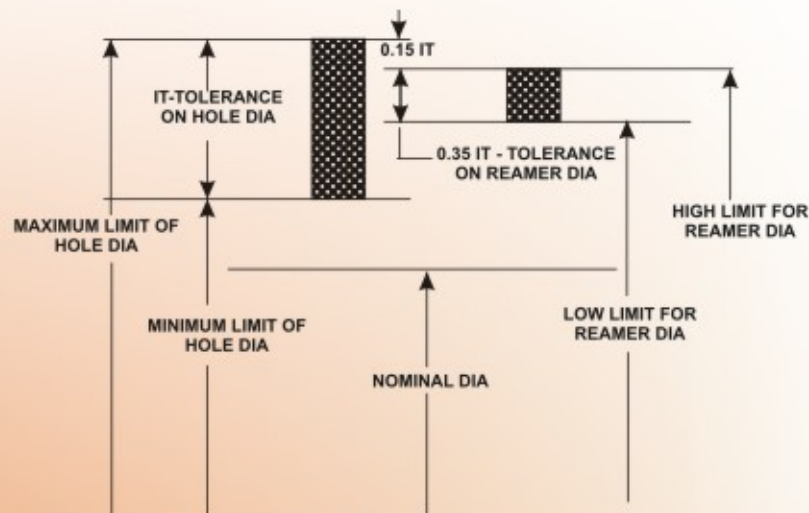

-Example:

For a 12H7 hole

$$\begin{aligned} \text{IT} = 0.018 \text{ hole size maximum limit} &= 12.018 \\ \text{Minimum limit} &= 12.000 \end{aligned}$$

$$\begin{aligned} \text{Maximum limit of reamer diameter} &= \text{maximum limit of the hole} - 0.15 \text{ IT} \\ &= 12.018 - 0.15 \times 0.018 = 12.018 - 0.0027 \\ &= 12.018 - 0.003 = 12.015 \end{aligned}$$

$$\begin{aligned} \text{Minimum limit of reamer diameter} &= \text{Maximum limit of the reamer diameter} - 0.35 \text{ IT} \\ &= 12.015 - 0.35 \times 0.018 = 12.015 - 0.0063 \\ &= 12.015 - 0.007 = 12.008 \end{aligned}$$



RECOMMENDED UNDERSIZES FOR REAMING

Material	Range of diameter of bore				
	From 3 Upto 5	Over 5 Upto 10	Over 10 Upto 20	Over 20 Upto 30	Over 30
Steel upto 70 Kg/ mm ² Cast iron Plastics - soft	0.1 - 0.2	0.2	0.2	0.3	0.4
Steel 70 - 100 Kg/ mm ² Brass, Bronze	0.1 - 0.2	0.2	0.2	0.3	0.3
Copper, Light metals	0.1 - 0.2	0.3	0.3	0.4	0.5
Malleable cast iron	0.1 - 0.2	0.2	0.3	0.4	0.5
Plastic - hard	0.1 - 0.2	0.3	0.4	0.4	0.5
Steel casting	0.1 - 0.2	0.2	0.2	0.2	0.3

Values shown are in mm.

To obtain optimal surface quality when reaming hard material the above values for allowances to be halved and preferably performed in two operations pre-finishing and finishing. If pre - drill hole finish is obtained rough the above values may have to be increased slightly

TYPICAL REAMER FAILURES

OBSERVATION	REASON	REMEDY
Increased reamer wear, Variation of hole size such as Tapered oversize or bell-mouthed.	Check the reamer alignment	Remove mis-alignment or use adjustable reamer holder.
Chatter mark In the hole or poor quality of reamed hole	Insucure holding of Job of Fixture Excessive speed of reamer or Spindle Feed is to low	Improve all the reasons mentioned



REAMING SPEEDS

Reaming Speeds – Vary considerably depending on part of the material to be reamed, type of machine and finish and accuracy required. Generally reaming is done at about – 2/3 the speed used for drilling the same material. Speed for drilling are shown on page 72

Material to be reamed	Speed 'Vc'	
	Ft. per min	M per min
Aluminium and Aluminium Alloys	135 - 200	41 – 60
Bakelite, Vulcanite, etc	65 - 100	20 – 30
Brass	100 - 160	30 – 48
Brass - leaded	135 - 200	41 – 60
Bronze: ordinary	65 - 135	20 – 41
: High tensile	45 - 65	14 – 20
Cast Iron: Soft	65 - 100	20 – 30
Medium	50 - 60	15 – 18
Hard	35 - 45	11 – 19
Chilled	15 - 25	5 – 8
Copper	65 - 135	20 – 41
Duralumin	65 - 135	20 – 41
Magnesium and Magnesium alloys	160 - 265	48 – 80
Malleable iron	45 - 50	14 – 15
Monel Metal	25 - 35	8 – 11
Zinc base die – casting material (Mazak)	135 - 200	41 – 60
Slate, Stone, Marble	10 - 15	3 – 5
Steel: Free - cutting	65 - 100	20 – 30
Up to 40 tons tensile	50 - 75	15 – 22
40 – 60 tons tensile	30 - 45	9 – 14
60 – 80 tons tensile	20 - 30	6 – 9
Over 80 tons tensile	10 - 15	3 – 5
Manganese	10 - 15	3 – 5
Stainless steel - Martensitic, Ferritic and Austenitic	20 - 50	6 – 15
Stainless steel – free cutting	30 - 80	9 – 24
Wood	200 - 265	60 - 80



REAMING FEEDS

Reaming Feeds – Feeds are usually much higher than those recommended for drilling the same material i.e. as much as 200 to 300% of drill feeds. Very low feed will result in more reamer wear. Very high feed may lower the finish and accuracy of hole. It is desirable to use high feed at the same time finish and accuracy should be achieved.

Diameter of reamer in mm		Feed mm/ rev
Over	Upto & Including	
-	4	0.06 – 0.2
4	6	0.10 – 0.3
6	10	0.12 – 0.4
10	16	0.16 – 0.6
16	20	0.20 – 0.8
20	25	0.24 – 1.0
25	40	0.30 – 1.2
40	63	0.40 – 1.2



INDEX

Product	DESCRIPTION	Specification	Pg. No.
	Cylindrical Milling Cutters	IS 6309 : 2002 ISO 2584 : 1972 DIN 864 : 1976 BS 122 Part 1 : 1989	106-108
	Side and Face cutters (Straight Teeth & Staggered Teeth)	IS 6308 : 2002 ISO 2587 : 1972 DIN 1885 : 1976 BS 122 Part 1 : 1989	109-112
	Shell End Mills	IS 6257 : 2002 ISO 2586 : 1973 DIN 1880 : 1976 BS 122 Part 1 : 1989	113-114
	Single Angle Cutters	IS 6324 : 2001 BS 122 Part 1 : 1989	115-116
	Double Angle Cutters	IS 6325 : 2001 BS 122 Part 1 : 1989	117-118
	Equal Angle Cutters	IS 6326 : 2001 ISO 6108 : 1978 BS 122 Part 1 : 1989	119-120
	Shell End Single Angle Milling Cutters	IS 6256 : 2000 DIN 842 (P-1) : 1984	121
	Face Cutters	BS 122 Part 1 : 1989	122
	Slotting Cutters	BS 122 Part 1 : 1989	123
	Keyway Milling Cutters	IS 6355 : 2002 ISO 2585 : 1972 DIN 1890 : 1976	124-125
	Hollow Mills	BS 122 Part 1 : 1989	126
	Convex Milling Cutters	IS 6323 : 2002 ISO 3860 : 1976 DIN 856 (Teil 1) : 1978 BS 122 Part 1 : 1989	127-128
	Concave Milling Cutters	IS 6322 : 2002 ISO 3860 : 1976 DIN 855 (Teil - 1) : 1978 BS 122 Part 1 : 1989	129-130
	Single Corner Rounding Cutter	IS 6314 : 2002 ISO 3860 : 1976 DIN 6513 (Teil - 1) : 1978 BS 122 Part 1 : 1989	131-132
	Double Corner Rounding Cutters	BS 122 Part 1 : 1989	133



MILLING CUTTERS (BORE TYPE)

Experttoolings.com

INDEX

PRODUCT	DESCRIPTION	Specification	Pg. No.
	Parallel Shank Milling Cutters	IS 6352 : 2001 ISO 1641/1 : 1978 BS 122 Part 1 : 1989	134-135
	Taper Shank Slot Milling Cutters	IS 6388 : 2001 ISO 1641/2 : 1978 BS 122 Part 1 : 1989	136-137
	Parallel Shank End Mills	IS 6353 : 2001 ISO 1641/1 : 1978 DIN 844 (Part 1) : 1978 BS 122 Part 1 : 1989	138-139
	Taper Shank End Mills	IS 6354 : 2001 ISO 1641/2 : 1978 DIN 845 Part 1 : 1981 BS 122 Part 1 : 1989	140-141
	Screwed Shank Slot Drills Short Series, Long Series	BS:122 Part 4 : 1980	142-145
	Screwed Shank End Mills Short Series, Long Series	BS:122 Part 4 : 1980	146-149
	T' Slot Cutters with Parallel Shank	IS 2668 : 2004 ISO 3337 : 2000	150
	T' Slot Cutters with Taper Shank	IS 2668 : 2004 ISO 3337 : 2000 BS 122 Part 1 : 1989	151-152
	Dove - Tail Milling Cutters	IS 6255 : 2000 ISO 3859 : 1977 DIN 1833 (Tail 1) : 1983	153
	Woodruff Keyslot Milling Cutters with Parallel Shank	IS 2669 : 2001 BS 122 Part 1 : 1989	154-155
	Countersinks 90° with Parallel Shank & Solid Pilot	IS 5693 : 2002 ISO 4206 : 1991 BS 122 Part 1 : 1989 BS 328 Part 6 : 1992	156
	Countersinks 90° with MT Shank & Detachable Pilot	IS 5703 : 2002 ISO 4204 : 1977 DIN 1867 : 1975	157
	Counterbores with Parallel Shank & Solid Pilot	IS 5704 : 2002 ISO 4206 : 1977 DIN 373 : 1975	158
	Counterbores with Taper Shank & Detachable Pilot	IS 5710 : 2002 ISO 4207 : 1977 BS 328 Part 5 : 1991 DIN 375 : 1975	159
	Countersinks with included angle 60°, 90° & 120° with parallel Shank	IS 13304 : 2002 ISO 3294 : 1975 DIN 334 : 1979 DIN 335 : 1979 DIN 347 : 1962	160
	Countersinks with included angle 60°, 90° & 120° with Taper Shank	IS 13303 : 2002 ISO 3294 : 1975 DIN 334 : 1979 DIN 335 : 1979 DIN 347 : 1962	161-162
	Technical Section		163-166



MILLING CUTTERS (SHANK TYPE)

Experttoolings.com

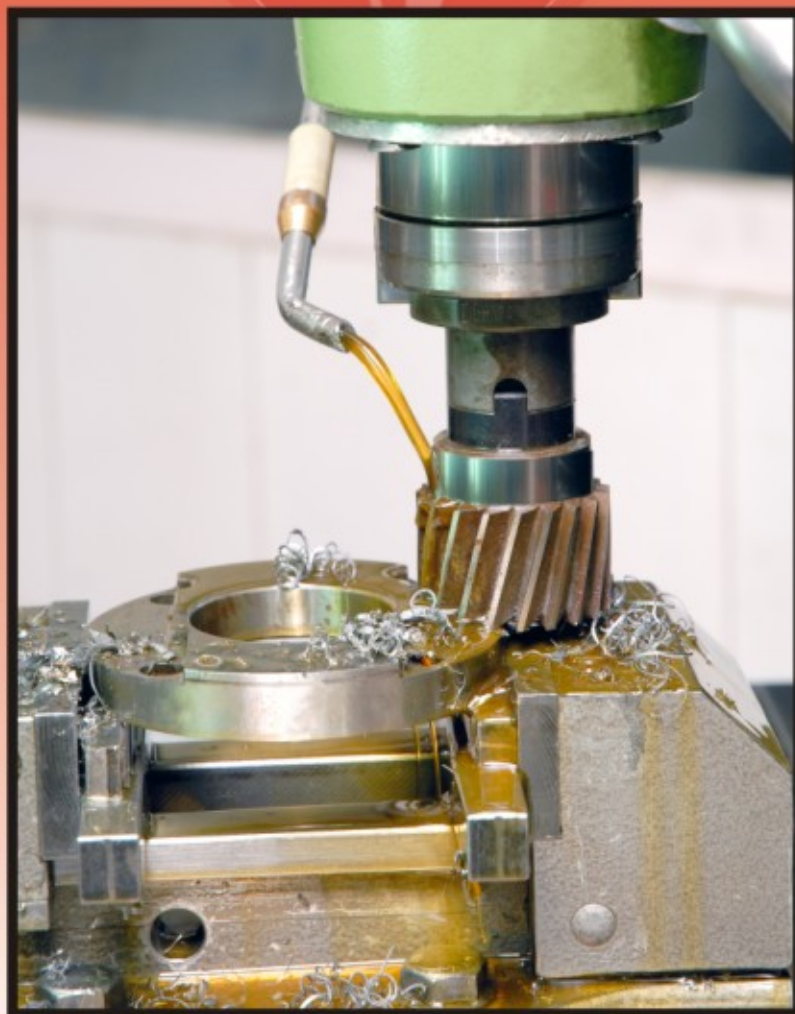



Elements of a Milling Cutter and Related terms

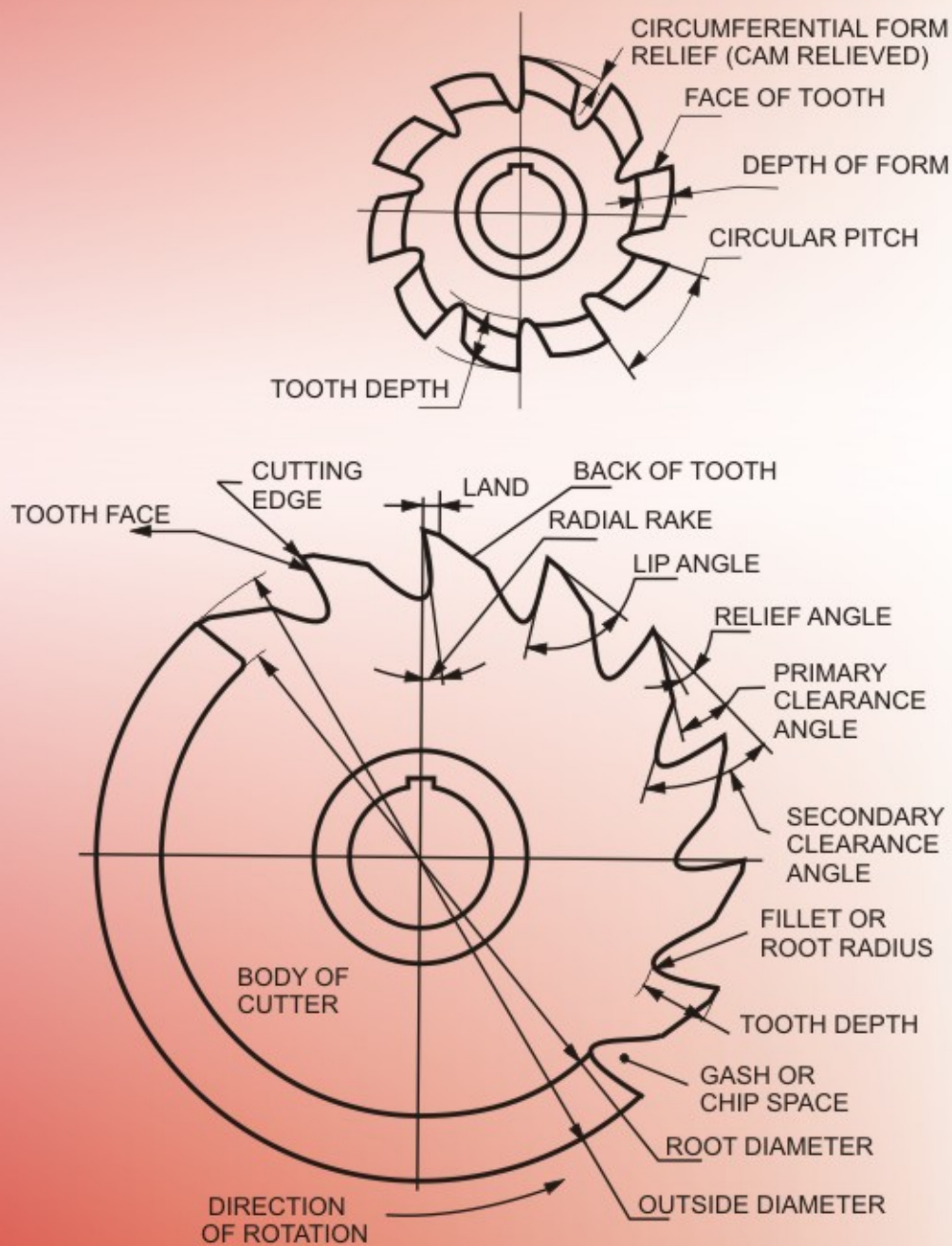

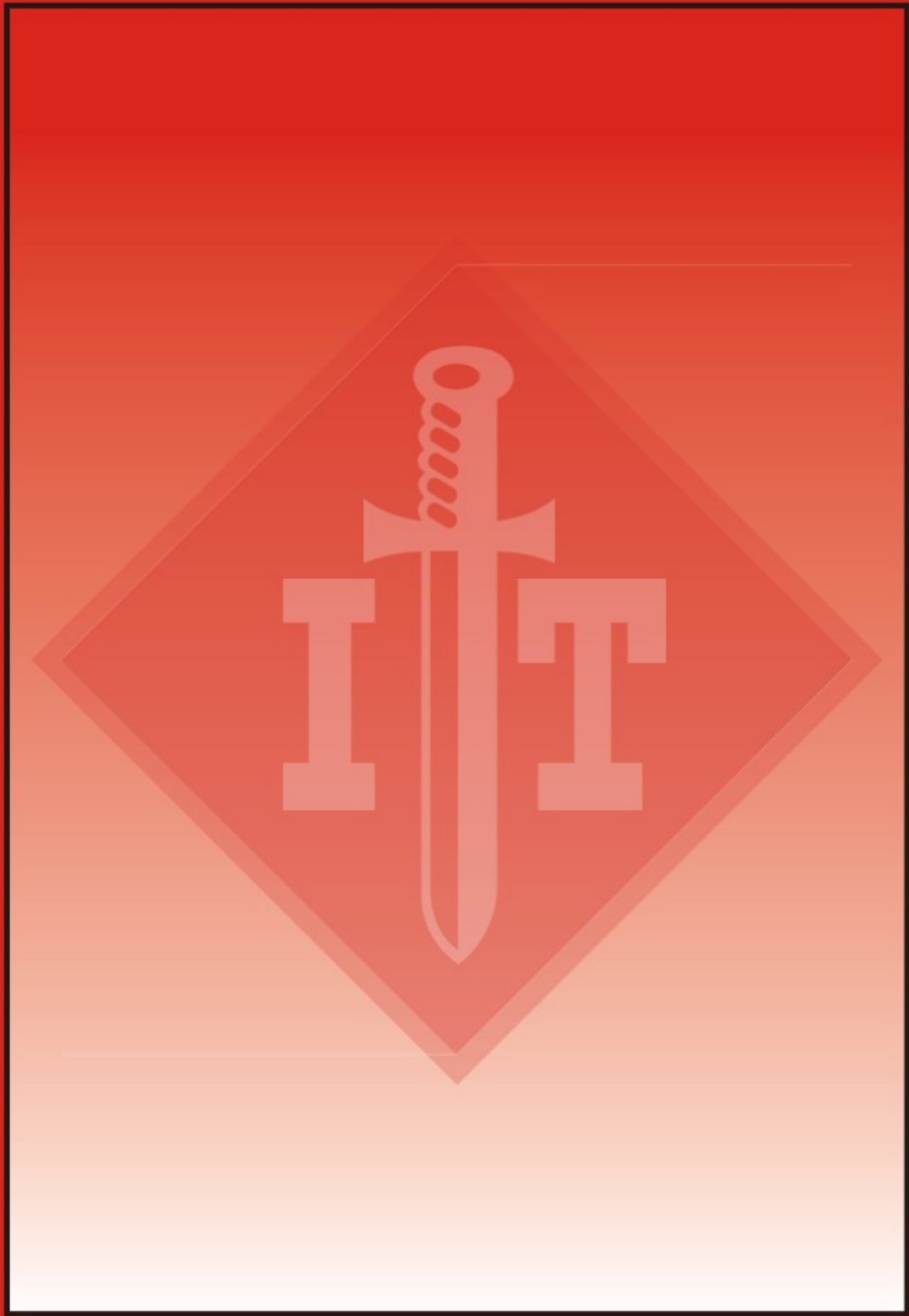

Experttoolings.com



MILLING CUTTERS



Dimensions in mm
Specifications conform to
IS 6309 : 2002
ISO 2584 : 1972
DIN 884 : 1976

High Speed Steel CYLINDRICAL MILLING CUTTERS

Diameter (js16)	Bore (H7)	Length (js16)
50	22	40
50	22	63
50	22	80
63	27	50
63	27	70
80	32	63
80	32	100
100	40	70
100	40	125
125	50	80
125	50	125
160	60	125

These Cutters have RH helix
Normally type N tools are supplied.

**High Speed Steel
CYLINDRICAL MILLING CUTTERS
(HIGH POWER TYPE)**



Diameter +0.045 -0.0	Bore +0.00075 +0.00025	Length
2.1/2	1	1
2.1/2	1	2
2.1/2	1	3
2.1/2	1	4
3	1.1/4	1
3	1.1/4	2
3	1.1/4	3
3	1.1/4	4
3	1.1/4	5
3	1.1/4	6
3.1/2	1.1/4	2
3.1/2	1.1/4	3
3.1/2	1.1/4	4
3.1/2	1.1/4	5
3.1/2	1.1/4	6
3.1/2	1.1/4	7
4	1.1/4 or 1.1/2	2
4	1.1/4 or 1.1/2	3
4	1.1/4 or 1.1/2	4
4	1.1/4 or 1.1/2	5
4	1.1/4 or 1.1/2	6
4	1.1/4 or 1.1/2	7
4	1.1/4 or 1.1/2	8
4.1/2	1.1/2 or 2	2
4.1/2	1.1/2 or 2	3
4.1/2	1.1/2 or 2	4
4.1/2	1.1/2 or 2	5
4.1/2	1.1/2 or 2	6
4.1/2	1.1/2 or 2	7
4.1/2	1.1/2 or 2	8
4.1/2	1.1/2 or 2	9

These Cutters have LH helix
Normally type N tools are supplied.

Tolerance on overall length
6 - inch and below +0.030 inch
-0.0
above 6 - inch +0.060 inch
-0.0



Dimensions in inches
Specifications conform to
BS 122 Part 1 : 1989

MILLING CUTTERS

Range of Application:
Used mainly for surface cutting



MILLING CUTTERS



Dimensions in inches
Specification conform to
BS 122 Part 1 : 1989

High Speed Steel CYLINDRICAL MILLING CUTTERS (HELICAL TYPE)

Diameter +0.045 -0.0	Bore +0.00075 +0.00025	Length
3	1.1/4	2
3	1.1/4	3
3	1.1/4	4
3	1.1/4	6
4	1.1/2	2
4	1.1/2	3
4	1.1/2	4
4	1.1/2	6
5	1.1/2 or 2	2
5	1.1/2 or 2	3
5	1.1/2 or 2	4
5	1.1/2 or 2	6

These Cutters have LH helix
Normally type N tools are supplied.

Tolerance on overall length
6 - inch and below +0.030 inch
-0.0
above 6 - inch +0.060 inch
-0.0

**High Speed Steel
SIDE AND FACE CUTTERS
(Straight Teeth)**



Diameter (js16)	Width (k11)	Bore (H7)
50	4	16
50	5	16
50	6	16
50	8	16
50	10	16
63	4	22
63	5	22
63	6	22
63	8	22
63	10	22
63	12	22
63	14	22
63	16	22
80	5	27
80	6	27
80	8	27
80	10	27
80	12	27
80	14	27
80	16	27
80	18	27
80	20	27
100	6	32
100	8	32
100	10	32
100	12	32
100	14	32
100	16	32
100	18	32
100	20	32
100	22	32
100	25	32
125	8	32
125	10	32
125	12	32
125	14	32
125	16	32
125	18	32
125	20	32
125	22	32
125	25	32
125	28	32
160	10	40
160	12	40
160	14	40
160	16	40
160	18	40

Normally type N tools are supplied.

Range of Application:
Used for end and face cutting



Dimensions in mm
Specification conform to :
IS 6308 : 2002
ISO 2587 : 1972
DIN 1885 : 1976

MILLING CUTTERS



MILLING CUTTERS



Dimensions in mm
Specifications conform to
IS 6308 : 2002
ISO 2587 : 1972
DIN 1885 : 1976

High Speed Steel SIDE AND FACE CUTTERS (Straight Teeth)

Diameter (js16)	Width (k11)	Bore (H7)
160	20	40
160	22	40
160	25	40
160	28	40
160	32	40
200	12	40
200	14	40
200	16	40
200	18	40
200	20	40
200	22	40
200	25	40
200	28	40
200	32	40
200	36	40
200	40	40

Normally type N tools are supplied.

Type A - Staggered Teeth

Type B - Straight Teeth

**High Speed Steel
SIDE AND FACE CUTTERS
(Straight Teeth)**



Diameter +0.045 -0.0	Bore +0.00075 +0.00025	Width +0.0005 -0.0
2.1/2	1	1/4
2.1/2	1	5/16
2.1/2	1	3/8
2.1/2	1	1/2
3	1	1/4
3	1	5/16
3	1	3/8
3	1	1/2
3	1	5/8
3.1/2	1	1/4
3.1/2	1	5/16
3.1/2	1	3/8
3.1/2	1	7/16
3.1/2	1	1/2
3.1/2	1	5/8
3.1/2	1	3/4
4	1or1.1/4	1/4
4	1or1.1/4	3/8
4	1or1.1/4	1/2
4	1or1.1/4	5/8
4	1or1.1/4	3/4
4	1or1.1/4	7/8
4	1or1.1/4	1
5	1.1/4	1/2
5	1.1/4	5/8
5	1.1/4	3/4
5	1.1/4	7/8
5	1.1/4	1
6	1.1/4or1.1/2	1/2
6	1.1/4or1.1/2	5/8
6	1.1/4or1.1/2	3/4
6	1.1/4or1.1/2	7/8
6	1.1/4or1.1/2	1
6	1.1/4or1.1/2	1.1/4
7	1.1/2	1/2
7	1.1/2	5/8
7	1.1/2	3/4
7	1.1/2	7/8
7	1.1/2	1
7	1.1/2	1.1/4
8	1.1/2	5/8
8	1.1/2	3/4
8	1.1/2	7/8
8	1.1/2	1
8	1.1/2	1.1/4
8	1.1/2	1.1/2

Normally type N tools are supplied.
Width 3/4 inch and above are normally supplied with LH helical teeth.

Range of Application:
Used for end and face cutting



Dimensions in inches
Specifications conform to
BS 122 Part 1 : 1989

MILLING CUTTERS



MILLING CUTTERS



Dimensions in inches
Specifications conform to
BS 122 Part 1 : 1989

High Speed Steel SIDE AND FACE CUTTERS (Staggered Teeth)

Diameter +0.045 -0.0	Bore +0.00075 +0.00025	Width +0.0005 -0.0
3	1	1/4
3	1	5/16
3	1	3/8
3	1	1/2
4	1	1/4
4	1	5/16
4	1	3/8
4	1	1/2
4	1	5/8
5	1.1/4	3/8
5	1.1/4	1/2
5	1.1/4	5/8
6	1.1/4	3/8
6	1.1/4	1/2
6	1.1/4	5/8
6	1.1/4	3/4
7	1.1/2	1/2
7	1.1/2	5/8
7	1.1/2	3/4
7	1.1/2	7/8
8	1.1/2	5/8
8	1.1/2	3/4
8	1.1/2	7/8
8	1.1/2	1

**High Speed Steel
SHELL END MILLS**



Diameter (js16)	Bore (H7)	Width (k16)
40	16	32
50	22	36
63	27	40
80	27	45
100	32	50
125	40	56
160	50	63

These cutter have RH hetix for RH cutting
Normally type N Tools are supplied



Dimensions in mm
Specifications conform to
IS 6257 : 2002
ISO 2586 : 1973
DIN 1880 : 1976

Range of Application:
Used for end and face cutting with Stubbarbor



MILLING CUTTERS



Dimensions in inches
Specifications conform to
BS 122 Part 1-1989

High Speed Steel SHELL END MILLS

Diameter +0.045 -0.0	Length +0.030 -0.0	Bore +0.00075 +0.00025
1.1/4	1	1/2
1.1/2	1.1/8	1/2
1.3/4	1.1/4	3/4
2	1.3/8	3/4
2.1/4	1.1/2	1
2.1/2	1.5/8	1
2.3/4	1.5/8	1
3	1.3/4	1.1/4
3.1/2	1.7/8	1.1/4
4	2.1/4	1.1/2
4.1/2	2.1/4	1.1/2
5	2.1/4	1.1/2
5.1/2	2.1/4	2
6	2.1/4	2

These Cutters have RH helix for RH cutting
Normally type N tools are supplied.

**High Speed Steel
SINGLE ANGLE CUTTERS**



Diameter (js16)	Bore H7 (H7)	Width (js16)	Angle° + 1°
50	16	12	60°, 65°, 70°, 75°
63	22	18	80° & 85°
63	22	26	
80	22	32	70°, 75° & 80°
100	27	36	

Normally RH cutters Type H tools are supplied



Dimensions in mm
Specifications conform to
IS 6324 : 2001

MILLING CUTTERS

Range of Application:

Used for milling vee - shaped single slots, serrations and chamfers



MILLING CUTTERS



Dimensions in inches
Specifications conform to
BS 122 Part 1 : 1989

High Speed Steel SINGLE ANGLE CUTTERS

Diameter +0.045 -0.0	Bore +0.00075 +0.00025	Width +0.015 -0.0	Angle° + 1°
2.3/4	1	5/16	30°
2.3/4	1	7/16	40°
2.3/4	1	1/2	45°, 50°, 60°
2.3/4	1	1/2	70° & 80°
3	1.1/4	5/16	30°
3	1.1/4	7/16	40°
3	1.1/4	1/2	45°
3	1.1/4	5/8	50°, 60°, 70°, 80°

Normally RH cutters are supplied

**High Speed Steel
DOUBLE ANGLE CUTTERS**



Diameter (js 16)	Bore H7 (H7)	Width (js16)	Small Angle $b + 1^\circ$	Included Angle $a + 1^\circ$
50	16	12	12	55
50	16	12	15	60
50	16	12	15	65
63	22	18	15	70
63	22	18	15	75
63	22	18	15	80
50	16	14	20	90
63	22	20	20	90
50	16	16	25	100
63	22	22	25	100
80	22	32	15	65
80	22	32	15	70
80	22	32	15	75
100	27	36	15	70
100	27	36	15	75
100	27	36	15	80

Normally RH cutters Type H tools are supplied



Dimensions in mm
Specifications conform to
IS 6325 : 2001

MILLING CUTTERS

Range of Application:

Used for milling vee - shaped single slots, serrations and chamfers



MILLING CUTTERS

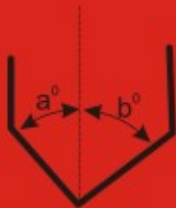

Dimensions in inches
 Specifications conform to:
 BS 122 Part 1 : 1989

High Speed Steel DOUBLE ANGLE CUTTERS

Diameter +0.045 -0.0	Bore +0.00075 +0.00025	Width +0.015 -0.0	Angle a° x b°
2.3/4	1	5/8	12x48
2.3/4	1	5/8	12x53
2.3/4	1	5/8	12x58
2.3/4	1	5/8	12x63
2.3/4	1	5/8	12x68
2.3/4	1	5/8	12x73
3	1.1/4	3/4	12x48
3	1.1/4	3/4	12x53
3	1.1/4	3/4	12x58
3	1.1/4	3/4	12x63
3	1.1/4	3/4	12x68
3	1.1/4	3/4	12x73

Normally RH cutters are supplied

Range of Application:

Used for milling vee - shaped single slots, serrations and chamfers

**High Speed Steel
EQUAL ANGLE CUTTERS**



Diameter (js16)	Bore H7 (H7)	Width (k11)	Included Angle° + 1°
50	16	8	45
50	16	10	60
50	16	14	90
63	22	10	45
63	22	14	60
63	22	20	90
80	27	12	45
80	27	18	60
80	27	22	90
100	22	18	45
100	32	25	60
100	32	32	90

Normally type H tools are supplied.



Dimensions in mm
Specifications conform to
IS 6326 : 2001
ISO 6108 : 1978

MILLING CUTTERS

Range of Application:

Used for milling vee - shaped single slots, serrations and chamfers



MILLING CUTTERS



Dimensions in inches
Specifications conform to
BS 122 Part 1 : 1989

High Speed Steel EQUAL ANGLE CUTTERS

Diameter +0.045 -0.0	Bore +0.00075 +0.00025	Width +0.015 -0.0	Included Angle°
2.3/4	1	5/16	30
2.3/4	1	7/16	40
2.3/4	1	1/2	45, 60 & 90
3	1.1/4	5/16	30
3	1.1/4	7/16	40
3	1.1/4	1/2	45
3	1.1/4	5/8	60 & 90

Normally type H tools are supplied.

Range of Application:

Used for milling vee - shaped single slots, serrations and chamfers

**High Speed Steel
SHELL END SINGLE ANGLE
MILLING CUTTERS**



Diameter (js 16)	Width (js 14)	Bore Dia (H7)	Included Angle°	Tolerance on Dia
40	10	10	45°	±25'
50	13	13	45°	±25'
63	18	16	45°	±25'
80	22	22	45°	±20'
100	28	27	45°	±20'
125	36	32	45°	±20'
160	45	40	45°	±20'
40	13	10	50°,55°,60°	±25'
50	16	13	50°,55°,60°	±25'
63	20	16	50°,55°,60°	±25'
80	25	22	50°,55°,60°	±20'
100	32	27	50°,55°,60°	±20'
125	40	32	50°,55°,60°	±20'
160	50	40	50°,55°,60°	±20'

Normally RH cutters and Type H tools are supplied



Dimensions in mm
Specifications conform to
IS 6256 : 2000
DIN 842 (P-1) : 1984

MILLING CUTTERS

Range of Application:

Used for milling vee - shaped single slots, serrations and chamfers



MILLING CUTTERS



Dimensions in inches
Specifications conform to
BS 122 Part 1 : 1989

High Speed Steel FACE CUTTERS

Diameter +0.045 -0.0	Length +0.030 -0.0	Bore +0.00075 +0.00025
1.3/4	1.1/4	3/4
2	1.1/4	3/4
2.1/2	1.1/4	3/4
3	1.11/16	1.1/8
4	1.3/4	1.1/8
5	2	1.1/2

These Cutters have RH helix for RH cutting
Normally type N tools are supplied.
Width above 3/4" are normally supplied with LH helical flutes.

**High Speed Steel
SLOTING CUTTERS**



Diameter +0.045 -0.0	Bore +0.00075 +0.00025	Width +0.001 -0.001
2.1/2	1	1/4
2.1/2	1	5/16
2.1/2	1	3/8
2.1/2	1	7/16
2.1/2	1	1/2
3	1	1/4
3	1	5/16
3	1	3/8
3	1	7/16
3	1	1/2
3	1	5/8
3	1	3/4
3.1/2	1	1/4
3.1/2	1	5/16
3.1/2	1	3/8
3.1/2	1	7/16
3.1/2	1	1/2
3.1/2	1	5/8
3.1/2	1	3/4
3.1/2	1	7/8
4	1	1/4
4	1	5/16
4	1	3/8
4	1	7/16
4	1	1/2
4	1	5/8
4	1	3/4
4	1	7/8
4	1	1
5	1.1/4	1/4
5	1.1/4	5/16
5	1.1/4	3/8
5	1.1/4	7/16
5	1.1/4	1/2
5	1.1/4	5/8
5	1.1/4	3/4
5	1.1/4	7/8
5	1.1/4	1
6	1.1/4	1/4
6	1.1/4	5/16
6	1.1/4	3/8
6	1.1/4	7/16
6	1.1/4	1/2
6	1.1/4	5/8
6	1.1/4	3/4
6	1.1/4	7/8
6	1.1/4	1

Width 3/4 and above are normally supplied with LH helical flutes.

Range of Application:
Used for milling slot

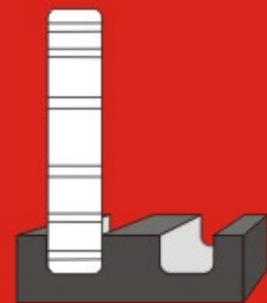

Dimensions in inches
Specifications conform to
BS 122 Part 1 : 1989

MILLING CUTTERS



MILLING CUTTERS



Dimensions are in mm
 Specifications conform to
 IS 6355 : 2002
 ISO 2585 : 1972
 DIN 1890 : 1976

High Speed Steel KEYWAY MILLING CUTTERS

Diameter (js16)	Bore (H7)	Width (d9)
50	16	4
50	16	5
50	16	6
50	15	8
50	16	10
63	22	4
63	22	5
63	22	6
63	22	8
63	22	10
63	22	12
63	22	14
80	27	5
80	27	6
80	27	8
80	27	10
80	27	12
80	27	14
80	27	16
80	27	18
100	32	6
100	32	8
100	32	10
100	32	12
100	32	14
100	32	16
100	32	18
100	32	20
100	32	22
100	32	25
125	32	8
125	32	10
125	32	12
125	32	14
125	32	16
125	32	18
125	32	20
125	32	22
125	32	25
160	40	10
160	40	12
160	40	14
160	40	16
160	40	18
160	40	20
160	40	22
160	40	25

Normally RH cutting and Type N tools are supplied

Range of Application:
 For milling keyway slot

**High Speed Steel
KEYWAY MILLING CUTTERS**



Diameter (js16)	Bore (H7)	Width (d9)
160	40	28
160	40	32
200	40	12
200	40	14
200	40	16
200	40	18
200	40	20
200	40	22
200	40	25
200	40	28
200	40	32
200	40	36
200	40	40

Normally RH cutting and type N tools are supplied.



Dimensions are in mm
Specifications conform to
IS 6355 : 2002
ISO 2585 : 1972
DIN 1890 : 1976

MILLING CUTTERS

Range of Application:
For milling keyway slot



MILLING CUTTERS



Dimensions in inches
Specifications conform to
BS 122 Part 1 : 1989

High Speed Steel HOLLOW MILLS

Bore +0.0 -0.002	Outside diameter	Overall length
1/4	5/8	1.1/2
9/32	3/4	1.1/2
5/16	3/4	1.1/2
11/32	3/4	1.1/2
3/8	1	1.3/4
7/16	1	1.3/4
1/2	1	1.3/4
9/16	1.1/4	2
5/8	1.1/4	2
11/16	1.1/2	2
3/4	1.1/2	2
13/16	1.1/2	2
7/8	1.3/4	2.1/4
15/16	1.3/4	2.1/4
1	1.3/4	2.1/4

Normally supplied for RH cutting

Tolerance on outside diameter
1 - inch and below -0.0007 inch
-0.0012 inch
above 1 - inch -0.0007 inch
-0.0015 inch

Range of Application:
For hollow end milling

**High Speed Steel
CONVEX MILLING CUTTERS**



Radius (k11)	Diameter (js 16)	Bore (H7)	Width
1.6	50	16	3.2
2	50	16	4
2.5	63	22	5
3	63	22	6
3.15	63	22	6.3
4	63	22	8
5	63	22	10
6	80	27	12
6.3	80	27	12.6
8	80	27	16
10	100	32	20
12	100	32	24
12.5	100	32	25
16	125	32	32
20	125	32	40

Normally type N tools are supplied.

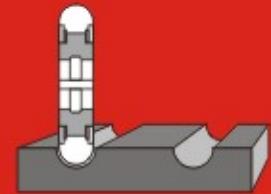

MILLING CUTTERS

Dimensions in mm
Specifications conform to
IS 6323 : 2002
ISO 3860 : 1976
DIN 856 (Teil 1) : 1978

Range of Application:
For milling concave slots



MILLING CUTTERS

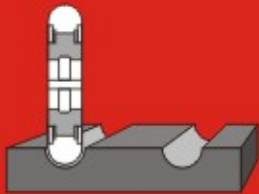

Dimensions in inches
Specifications conform to
BS 122 Part 1 : 1989

High Speed Steel CONVEX MILLING CUTTERS

Diameter +0.045 -0.0	Width & circle diameter	Bore +0.00075 +0.00025
2.1/4	1/8	1
2.1/4	3/16	1
2.1/4	1/4	1
2.1/2	5/16	1
2.1/2	3/8	1
2.1/2	7/16	1
2.1/2	1/2	1
2.3/4	9/16	1
2.3/4	5/8	1
3	11/16	1
3	3/4	1
3.1/4	13/16	1
3.1/4	7/8	1
3.1/2	15/16	1
3.1/2	1	1
4	1.1/8	1.1/4
4	1.1/4	1.1/4
4.1/4	1.3/8	1.1/4
4.1/4	1.1/2	1.1/4

Tolerance on width
 5/8 - inch and below +0.002 inch
 -0.0
 above 5/8 - inch +0.004 inch
 -0.0

Range of Application:
For milling concave slots

**High Speed Steel
CONCAVE MILLING CUTTERS**



Radius (N11)	Diameter (js16)	Bore (H7)	Width
1.6	50	16	8
2	50	16	9
2.5	63	22	10
3	63	22	12
3.15	63	22	12
4	63	22	16
5	63	22	20
6	80	27	24
6.3	80	27	24
8	80	27	32
10	100	32	36
12	100	32	40
12.5	100	32	40
16	125	32	50
20	125	32	60

Normally types N tools are supplied.



Dimensions in mm
 Specifications conform to
 IS 6322 : 2002
 ISO 3860 : 1976
 DIN 855 (Teil - 1) : 1978

MILLING CUTTERS

Range of Application:
 For milling convex slots



MILLING CUTTERS



Dimensions in Inches
Specifications conform to
BS 122 Part 1 : 1989

High Speed Steel CONCAVE MILLING CUTTERS

Diameter +0.045 -0.0	Circle diameter	Width +0.010 -0.0	Bore +0.00075 +0.00025
2.1/4	1/8	5/16	1
2.1/4	3/16	3/8	1
2.1/4	1/4	1/2	1
2.1/2	5/16	5/8	1
2.1/2	3/8	3/4	1
2.1/2	7/16	7/8	1
2.1/2	1/2	1	1
2.3/4	9/16	1.3/16	1
2.3/4	5/8	1.3/16	1
3	11/16	1.3/8	1
3	3/4	1.3/8	1
3.1/4	13/16	1.9/16	1
3.1/4	7/8	1.9/16	1
3.1/2	15/16	1.3/4	1
3.1/2	1	1.3/4	1
4	1.1/8	1.15/16	1.1/4
4	1.1/4	2.1/8	1.1/4
4.1/4	1.3/8	2.5/16	1.1/4
4.1/4	1.1/2	2.1/2	1.1/4

Tolerance on circle diameter
5/8 - inch and below +0.0 inch
-0.002 inch
above 5/8 - inch +0.0 inch
-0.004 inch

**High Speed Steel
SINGLE CORNER ROUNDING CUTTERS**



Diameter (js16)	Bore (H7)	Width	Radius (N11)
50	16	5	1.6
50	16	5	2
63	22	5	2.5
63	22	6	3
63	22	6	3.15
63	22	8	4
63	22	10	5
80	27	12	6
80	27	12	6.3
80	27	16	8
100	32	18	10
100	32	20	12
100	32	20	12.5
125	32	24	16
125	32	28	20

Normally RH cutters and Type N tools are supplied



Dimensions in mm
Specifications conform to
IS 6314 : 2002
ISO 3860 : 1976
DIN 6513 (Teil - 1) : 1978

MILLING CUTTERS

Range of Application:
For milling convex type single corner rounding form



MILLING CUTTERS



Dimensions are in inches
Specifications conform to
BS 122 Part 1 : 1989

High Speed Steel SINGLE CORNER ROUNDING CUTTERS

Diameter +0.045 -0.0	Radius	Bore +0.00075 +0.00025	Width +0.010 -0.0
2.1/4	1/16	1	5/16
2.1/4	3/32	1	5/16
2.1/4	1/8	1	5/16
2.1/2	5/32	1	7/16
2.1/2	3/16	1	7/16
2.1/2	7/32	1	1/2
2.1/2	1/4	1	1/2
2.3/4	9/32	1	5/8
2.3/4	5/16	1	5/8
3	11/32	1	11/16
3	3/8	1	11/16
3.1/4	13/32	1	3/4
3.1/4	7/16	1	3/4
3.1/2	15/32	1	7/8
3.1/2	1/2	1	7/8
3.1/2	9/16	1	1
3.1/2	5/8	1	1
3.3/4	11/16	1	1.1/8
3.3/4	3/4	1	1.1/8

Tolerance on Radius

5/16 - inch and below +0.0 inch
-0.001 inch
above 5/16 - inch +0.0 inch
-0.002inch

Range of Application:

For milling convex type single corner rounding form

**High Speed Steel
DOUBLE CORNER ROUNDING CUTTERS**



Diameter +0.045 -0.0	Corner radius	Bore +0.00075 +0.00025	Width +0.010 -0.0
2.1/4	1/16	1	7/16
2.1/4	3/32	1	7/16
2.1/4	1/8	1	7/16
2.1/2	5/32	1	5/8
2.1/2	3/16	1	5/8
2.1/2	7/32	1	3/4
2.1/2	1/4	1	3/4
2.3/4	9/32	1	15/16
2.3/4	5/16	1	15/16
3	11/32	1	1.1/16
3	3/8	1	1.1/16
3.1/4	13/32	1	1.3/16
3.1/4	7/16	1	1.3/16
3.1/2	15/32	1	1.3/8
3.1/2	1/2	1	1.3/8
3.1/2	9/16	1	1.5/8
3.1/2	5/8	1	1.5/8
3.3/4	11/16	1	1.7/8
3.3/4	3/4	1	1.7/8

Tolerance on Corner Radius
 5/16 - inch and below +0.0 inch
 -0.001 inch
 above 5/16 - inch +0.0 inch
 -0.002inch



Dimensions in inches
 Specifications conform to
 BS 122 Part 1 : 1989

MILLING CUTTERS

Range of Application:
 For milling concave type double rounding form



MILLING CUTTERS



Dimensions in mm
 Specifications conform to
 IS 6352 : 2001
 ISO 1641/1 :1978

High Speed Steel PARALLEL SHANK SLOT MILLING CUTTERS

Diameter (e8)	Shank Diameter (h8)	Short Series		Standard Series	
		Cutting edge length	Overall length	Cutting edge length	Overall length
3	4	5	37	8	40
3.5	4	6	38	10	42
4	4	7	39	11	43
5	5	8	42	18	47
6	6	8	52	13	57
7	8	10	54	16	60
8	8	11	55	19	63
9	10	11	61	19	69
10	10	13	63	22	72
11	12	13	70	22	79
12	12	16	73	26	83
14	12	16	73	26	83
16	16	19	79	32	92
18	16	19	79	32	92
20	20	22	88	38	104
22	20	22	88	38	104
25	25	26	102	45	121
28	25	26	102	45	121
32	32	32	112	53	133
36	32	32	112	53	133
40	40	38	130	63	155
45	40	38	130	63	155
50	50	45	147	75	177
56	50	45	147	75	177
63	50	53	155	90	192
71	63	53	165	90	202

Type A - Flat Face Helical Fluted
 Type B - Concave Face Helical Fluted

Normally RH helical flutes RH cutting and type N tools
 are supplied with flat face - Type A

Range of Application:

For milling keyway slot in machine spindles

**High Speed Steel
PARALLEL SHANK SLOT DRILL**



Diameter	Cutting edge length	Overall length	Shank diameter
1/8	3/8	1.7/8	1/4
5/32	3/8	1.7/8	1/4
3/16	1/2	2	1/4
7/32	1/2	2	1/4
1/4	5/8	2.1/8	1/4
5/16	3/4	2.1/2	3/8
3/8	7/8	2.5/8	3/8
7/16	7/8	2.5/8	1/2
1/2	1	2.3/4	1/2
9/16	1.1/8	2.7/8	1/2
5/8	1.1/4	3.1/4	5/8
11/16	1.3/8	3.3/8	5/8
3/4	1.1/2	3.1/2	5/8
7/8	1.5/8	3.5/8	3/4
1	1.3/4	3.3/4	3/4
1.1/8	1.7/8	4.1/8	1
1.1/4	2	4.1/4	1
1.3/8	2.1/8	4.5/8	1
1.1/2	2.1/4	4.3/4	1

Normally straight flutes are supplied.
Tolerance on diameter & shank diameter
1/2 inches below= +0.0
-0.0005

Above 1/2 inches= +0.0
-0.001



Dimensions in inches
Specifications conform to
BS 122 Part 1 : 1989

MILLING CUTTERS

Range of Application:
For milling keyway slot in machine spindles



MILLING CUTTERS



Dimensions in mm
 Specifications conform to
 IS 6388 : 2001
 ISO 1641/2 : 1978

High Speed Steel TAPER SHANK SLOT MILLING CUTTERS (TAPPED END)

Diameter (e8)	Short Series		Standard Series		MT Shank no
	Cutting edge length	Overall length	Cutting edge length	Overall length	
7	10	80	16	86	1
8	11	81	19	89	1
9	11	81	19	89	1
10	13	83	22	92	1
11	13	83	22	92	1
12	16	86	26	96	1
14	16	86	26	96	1
16	19	104	32	117	2
18	19	104	32	117	2
20	22	107	38	123	2
22	22	107	38	123	2
25	26	128	45	147	3
28	26	128	45	147	3
32	32	134	53	155	3
36	32	157	53	178	4
40	38	163	63	188	4
45	38	196	63	221	5
50	45	170	75	200	4
56	45	203	75	223	5
63	53	211	90	248	5

Type D - Flat Face LH Helical Fluted
 Type F - Concave Face LH Helical Fluted
 Normally RH helical flutes RH cutting
 and Type H tools are supplied

**High Speed Steel
TAPER SHANK SLOT DRILL**



Diameter	Cutting edge length	Overall length	MT Shank no
1/8	3/8	3.3/8	1
5/32	3/8	3.3/8	1
3/16	1/2	3.1/2	1
7/32	1/2	3.1/2	1
1/4	5/8	3.5/8	1
5/16	3/4	3.3/4	1
3/8	7/8	3.7/8	1
7/16	7/8	3.7/8	1
1/2	1	4	1
9/16	1.1/8	4.3/4	2
5/8	1.1/4	4.7/8	2
11/16	1.3/8	5	2
3/4	1.1/2	5.1/8	2
7/8	1.5/8	5.1/4	2
1	1.3/4	6.1/8	3
1.1/8	1.7/8	6.1/4	3
1.1/4	2	6.3/8	3
1.3/8	2.1/8	7.5/8	4
1.1/2	2.1/4	7.3/4	4
45	38	196	63

Normally Straight flutes RH cutting and Type H tools are supplied

Tolerance on diameter

1/2 inches and below = +0.0
-0.0005

Above 1/2 inches = +0.0
-0.001



Dimensions in inches
Specifications conform to
BS 122 Part 1 : 1989

MILLING CUTTERS

Range of Application:
For milling keyway slot in machine spindles



MILLING CUTTERS

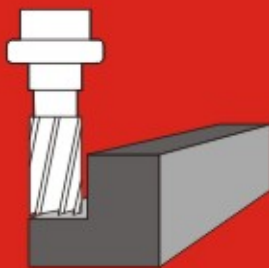

Dimensions in mm
 Specifications conform to
 IS 6353 : 2001
 ISO 1641/1 : 1978
 DIN 844 (Part 1) : 1978

High Speed Steel PARALLEL SHANK END MILLS

Diameter (js14)	Shank Diameter (h8)	Standard Series		Long Series	
		Cutting edge length	Overall length	Cutting edge length	Overall length
3	4	8	40	12	44
3.5	4	10	42	15	47
4	4	11	43	19	51
5	5	13	47	24	58
6	6	13	57	24	68
7	8	16	60	30	74
8	8	19	63	38	82
9	10	19	69	38	88
10	10	22	72	45	95
11	12	22	79	45	102
12	12	26	83	53	110
14	12	26	83	53	110
16	16	32	92	63	123
18	16	32	92	63	123
20	20	38	104	75	141
22	20	38	104	75	141
25	25	45	121	90	166
28	25	45	121	90	166
32	32	53	133	106	186
36	32	53	133	106	186
40	40	63	155	125	217
45	40	63	155	125	217
50	50	75	177	150	252
56	50	75	177	150	252
63	50	90	192	180	282
71	63	90	202	180	292

These cutters have RH helix RH cutting
 and Type N tools are supplied

Range of Application:
 For end milling operation

**High Speed Steel
PARALLEL SHANK END MILLS**



Diameter	Shank Dia	Cutting edge length	Overall length
1/8	1/4	3/8	1.7/8
5/32	1/4	3/8	1.7/8
3/16	1/4	1/2	2
7/32	1/4	1/2	2
1/4	1/4	5/8	2.1/8
5/16	3/8	3/4	2.1/2
3/8	3/8	7/8	2.5/8
7/16	1/2	7/8	2.5/8
1/2	1/2	1	2.3/4
9/16	1/2	1.1/8	2.7/8
5/8	5/8	1.1/4	3.1/4
11/16	5/8	1.3/8	3.3/8
3/4	5/8	1.1/2	3.1/2
13/16	3/4	1.5/8	3.5/8
7/8	3/4	1.5/8	3.5/8
1	3/4	1.3/4	3.3/4
1.1/8	1	1.7/8	4.1/8
1.1/4	1	2	4.1/4
1.3/8	1	2.1/8	4.5/8
1.1/2	1	2.1/4	4.3/4
1.5/8	1.1/4	2.3/8	4.7/8
1.3/4	1.1/4	2.1/2	5.1/8
1.7/8	1.1/4	2.5/8	5.1/4
2	1.1/2	3	5.1/2
2.1/8	1.1/2	3	5.1/2
2.1/4	1.1/2	3	5.5/8
2.3/8	1.1/2	3.1/4	5.7/8
2.1/2	1.1/2	3.1/2	6.1/8

These Cutters have RH helix RH cutting and Ttype N tools are supplied.

Tolerance on diameter

3/4 inches and below = +0.005
- 0.0

Above 3/4 inches = +0.010
0.0

Tolerance on shank diameter - 1/2 inches and below = +0.0
-0.0005
Above 1/2 inches = +0.0
-0.001



Dimensions in inches
Specifications conform to
BS 122 Part 1 : 1989

MILLING CUTTERS

Range of Application:
For end milling operation



MILLING CUTTERS

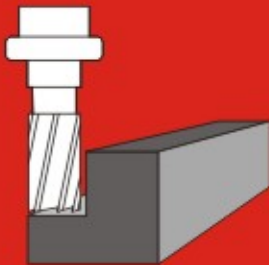

Dimensions in mm
 Specifications conform to
 IS 6354 : 2001
 ISO 1641/2 : 1978
 DIN 845 Part 1 : 1981

High Speed Steel TAPER SHANK END MILLS (TAPPED END)

Diameter (js14)	Standard Series		Long Series		MT Shank no
	Cutting edge length	Overall length	Cutting edge length	Overall length	
6	13	83	24	94	1
7	16	86	30	100	1
8	19	89	38	108	1
9	19	89	38	108	1
10	22	92	45	115	1
11	22	92	45	115	1
12	26	96	53	123	1
14	26	96	53	123	1
16	32	117	63	148	2
18	32	117	63	148	2
20	38	123	75	160	2
22	38	123	75	160	2
25	45	147	90	192	3
28	45	147	90	192	3
32	53	155	106	208	3
36	53	178	106	231	4
40	63	188	125	250	4
45	63	221	125	283	5
50	75	200	150	275	4
56	75	233	150	308	5
63	90	248	180	338	5

These Cutters have RH helix
 Normally type N tools are supplied.

High Speed Steel TAPER SHANK END MILLS



Diameter	Cutting edge length	Overall length		MT shank no
		Tanged end shank	Tapped end shank	
1/8	3/8	3.3/8		1
5/32	3/8	3.3/8		1
3/16	1/2	3.1/2		1
7/32	1/2	3.1/2		1
1/4	5/8	3.5/8		1
5/16	3/4	3.3/4		1
3/8	7/8	3.7/8		1
7/16	7/8	3.7/8		1
1/2	1	4		1
9/16	1.1/8	4.3/4	4.3/8	2
5/8	1.1/4	4.7/8	4.1/2	2
11/16	1.3/8	5	4.5/8	2
3/4	1.1/2	5.1/8	4.3/4	2
13/16	1.5/8	5.1/4	4.7/8	2
7/8	1.5/8	5.1/4	4.7/8	2
1	1.3/4	6.1/8	5.5/8	3
1.1/8	1.7/8	6.1/4	5.3/4	3
1.1/4	2	6.3/8	5.7/8	3
1.3/8	2.1/8	7.5/8	7.1/8	4
1.1/2	2.1/4	7.3/4	7.1/4	4
1.5/8	2.3/8	7.7/8	7.3/8	4
1.3/4	2.1/2	8	7.1/2	4
1.7/8	2.5/8	8.1/8	7.5/8	4
2	2.3/4	8.1/4	7.3/4	4
2.1/8	3	9.7/8	9.3/32	5
2.1/4	3	9.7/8	9.3/32	5
2.3/8	3.1/4	10.1/8	9.11/32	5
2.1/2	3.1/2	10.3/8	9.19/32	5
2.3/4	3.1/2	10.5/8	9.27/32	5
3	4	10.7/8	10.3/32	5

These Cutters have RH helix tapped end shank and LH helix for tanged end shank
Normally type N tools are supplied.

*Tolerance -

3/4 inches and below =+0.005
0.0

Above 3/4 inches =+0.010
0.0



Dimensions in inches
Specifications conform to
BS 122 Part 1 : 1989

MILLING CUTTERS

Range of Application:
For end milling operation



MILLING CUTTERS



Dimensions in mm
Specifications conform to:
BS 122 Part 4 : 1980

High Speed Steel SCREWED SHANK SLOT DRILL Short Series (Normal Series)

Diameter	Cutting edge length	Shank Diameter	Nominal Length below Chuck	Overall Length
3.0	7.0	6	13.5	51.0
3.5	7.5	6	15.0	52.5
4.0	9.5	6	15.0	52.5
4.5	9.5	6	15.0	52.5
5.0	9.5	6	15.0	52.5
5.5	11.0	6	18.0	55.5
6.0	11.0	6	19.0	56.5
6.5	11.0	10	20.5	58.5
7.0	11.0	10	20.5	58.5
7.5	11.0	10	20.5	58.5
8.0	12.5	10	21.5	59.5
8.5	14.5	10	22.5	60.5
9.0	14.5	10	22.5	60.5
9.5	14.5	10	22.5	60.5
10.0	14.5	10	22.5	60.5
10.5	17.5	12	27.0	65.0
11.0	17.5	12	27.0	65.0
11.5	17.5	12	27.0	65.0
12.0	19.0	12	28.5	66.5
13.0	19.0	12	28.5	66.5
14.0	22.0	12	30.5	68.5
15.0	22.0	16	33.0	72.0
16.0	22.0	16	33.0	72.0
17.0	24.0	16	35.0	74.0
18.0	24.0	16	35.0	74.0
19.0	25.5	16	38.0	77.0
20.0	25.5	16	38.0	77.0
21.0	25.5	25	46.0	98.5
22.0	25.5	25	47.5	100.0
23.0	25.5	25	49.0	101.5
24.0	25.5	25	50.5	103.0
25.0	27.0	25	42.5	95.0
26.0	27.0	25	42.5	95.0
27.0	28.5	25	41.0	93.5
28.0	30.0	25	42.5	95.0
29.0	30.0	25	41.0	93.5
30.0	30.0	25	41.0	93.5
32.0	38.0	25	49.0	101.5
34.0	38.0	25	49.0	101.5
35.0	39.5	25	50.5	103.0
36.0	39.5	25	50.5	103.0
38.0	43.0	25	54.0	106.5
40.0	46.0	25	58.5	111.0
42.0	47.5	25	60.0	112.5
44.0	51.0	25	63.5	116.0
45.0	51.0	25	63.5	116.0
50.0	51.0	32	63.5	117.5

Range of Application:
For milling Keyway slots

**High Speed Steel
SCREWED SHANK
SLOT DRILLS
Short Series (Normal Series)**



Diameter	Cutting edge length	Shank Diameter	Nominal Length below Chuck	Overall Length
1/8	9/32	1/4	17/32	2
5/32	3/8	1/4	19/32	2.1/16
3/16	3/8	1/4	19/32	2.1/16
7/32	7/16	1/4	23/32	2.3/16
1/4	7/16	1/4	3/4	2.7/32
9/32	7/16	3/8	13/16	2.5/16
5/16	1/2	3/8	27/32	2.11/32
11/32	9/16	3/8	7/8	2.3/8
3/8	9/16	3/8	7/8	2.3/8
13/32	5/8	3/8	7/8	2.3/8
7/16	11/16	1/2	1.1/16	2.9/16
15/32	11/16	1/2	1.1/16	2.9/16
1/2	3/4	1/2	1.1/8	2.5/8
9/16	27/32	1/2	1.7/32	2.23/32
5/8	7/8	5/8	1.5/16	2.27/32
11/16	15/16	5/8	1.3/8	2.29/32
3/4	1	5/8	1.1/2	3.1/32
13/16	1	1	1.13/16	3.7/8
7/8	1	1	1.7/8	3.15/16
15/16	1	1	2.0	4.1/16
1	1.1/16	1	1.11/16	3.3/4
1.1/16	1.1/8	1	1.5/8	3.11/16
1.1/8	1.3/16	1	1.11/16	3.3/4
1.3/16	1.3/16	1	1.5/8	3.11/16
1.1/4	1.1/2	1	1.15/16	4
1.5/16	1.1/2	1	1.15/16	4
1.3/8	1.9/16	1	2	4.1/16
1.7/16	1.9/16	1	2	4.1/16
1.1/2	1.11/16	1	2.1/8	4.3/16
1.5/8	1.7/8	1	2.3/8	4.7/16
1.3/4	2	1	2.1/2	4.9/16
1.7/8	2.1/8	1	2.5/8	4.11/16
2	2.1/4	1	2.3/4	4.13/16



Dimensions in inches
Specifications conform to:
BS:122 Part 4 : 1980

MILLING CUTTERS

Range of Application:
For milling Keyway slots



MILLING CUTTERS



Dimensions in mm
Specifications conform to:
BS 122 Part 4 : 1980

High Speed Steel SCREWED SHANK SLOT DRILL (Long Series)

Diameter	Cutting edge length	Shank Diameter	Nominal Length below Chuck	Overall Length
3.0	11.0	6	23.0	60.5
3.5	12.5	6	29.0	66.5
4.0	12.5	6	29.0	66.5
4.5	12.5	6	29.0	66.5
5.0	12.5	6	32.5	70.0
5.5	16.0	6	38.5	76.0
6.0	16.0	6	38.5	76.0
6.5	16.0	10	38.0	76.0
7.0	16.0	10	38.0	76.0
8.0	19.0	10	41.5	79.5
8.5	22.0	10	44.5	82.5
9.0	22.0	10	44.5	82.5
10.0	22.0	10	44.5	82.5
11.0	22.0	12	51.0	89.0
12.0	25.5	12	57.0	95.0
13.0	25.5	12	57.0	95.0
14.0	28.5	12	63.5	101.5
15.0	31.5	16	69.0	108.0
16.0	31.5	16	69.0	108.0
17.0	35.0	16	75.5	114.5
18.0	35.0	16	75.5	114.5
19.0	38.0	16	81.5	120.5
20.0	38.0	16	81.5	120.5
22.0	41.5	25	87.5	140.0
24.0	41.5	25	100.0	152.5
25.0	44.5	25	106.5	159.0
26.0	44.5	25	106.5	159.0
28.0	47.5	25	106.5	159.0
30.0	51.0	25	106.5	159.0
32.0	51.0	25	106.5	159.0
34.0	51.0	25	106.5	159.0
35.0	54.0	25	106.5	159.0
36.0	54.0	25	106.5	159.0
38.0	57.0	25	106.5	159.0
40.0	57.0	25	106.5	159.0
45.0	57.0	25	106.5	159.0

Range of Application:
For milling Keyway slots

**High Speed Steel
SCREWED SHANK
SLOT DRILL
(Long Series)**



Diameter	Cutting edge length	Shank Diameter	Nominal Length below Chuck	Overall Length
1/8	7/16	1/4	1.1/32	2.1/2
5/32	1/2	1/4	1.9/32	2.3/4
3/16	1/2	1/4	1.9/32	2.3/4
7/32	5/8	1/4	1.17/32	3
1/4	5/8	1/4	1.17/32	3
9/32	5/8	3/8	1.1/2	3
5/16	3/4	3/8	1.5/8	3.1/8
11/32	7/8	3/8	1.3/4	3.1/4
3/8	7/8	3/8	1.3/4	3.1/4
13/32	7/8	3/8	2	3.1/2
7/16	7/8	1/2	2	3.1/2
15/32	1	1/2	2.1/4	3.3/4
1/2	1	1/2	2.1/4	3.3/4
9/16	1.1/8	1/2	2.1/2	4
5/8	1.1/4	5/8	2.23/32	4.1/4
11/16	1.3/8	5/8	2.31/32	4.1/2
3/4	1.1/2	5/8	2.7/32	4.3/4
13/16	1.1/2	1	3.7/16	5.1/2
7/8	1.5/8	1	3.7/16	5.1/2
15/16	1.5/8	1	3.15/16	6
1	1.3/4	1	4.3/16	6.1/4
1.1/16	1.3/4	1	4.3/16	6.1/4
1.1/8	1.7/8	1	4.3/16	6.1/4
1.3/16	2	1	4.3/16	6.1/4
1.1/4	2	1	4.3/16	6.1/4
1.3/8	2.1/8	1	4.3/16	6.1/4
1.7/16	2.1/8	1	4.3/16	6.1/4
1.1/2	2.1/4	1	4.3/16	6.1/4
1.5/8	2.1/2	1	4.3/16	6.1/4
1.3/4	2.1/2	1	4.3/16	6.1/4
1.7/8	2.1/2	1	4.3/16	6.1/4
2	2.1/2	1	4.3/16	6.1/4



Dimensions in inches
Specifications conform to:
BS:122 Part 4 : 1980

MILLING CUTTERS

Range of Application:
For milling keyway slots



MILLING CUTTERS

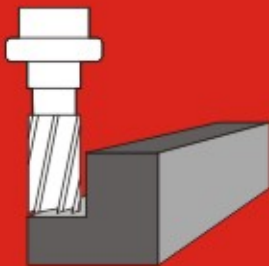

Dimensions in mm
Specifications conform to:
BS:122 Part 4 : 1980

High Speed Steel SCREWED SHANK END MILLS Short Series (Normal Series)

Diameter	Cutting edge length	Shank Diameter	Nominal Length below Chuck	Overall Length
3.0	9.5	6	16.5	54.0
3.5	12.5	6	19.5	57.0
4.0	12.5	6	19.5	57.0
4.5	12.5	6	19.5	57.0
5.0	16.0	6	23.0	60.5
5.5	16.0	6	23.0	60.5
6.0	16.0	6	23.0	60.5
6.5	16.0	10	22.5	60.5
7.0	15.0	10	22.5	60.5
7.5	18.0	10	25.5	63.5
8.0	18.0	10	25.5	63.5
8.5	21.0	10	28.5	66.5
9.0	21.0	10	28.5	66.5
9.5	21.0	10	28.5	66.5
10.0	21.0	10	28.5	66.5
10.5	19.0	12	28.5	66.5
11.0	19.0	12	28.5	66.5
11.5	22.5	12	32.0	70.0
12.0	24.0	12	32.0	70.0
13.0	24.5	12	32.0	70.0
14.0	28.5	12	35.0	73.0
15.0	26.5	16	38.0	77.0
16.0	26.5	16	38.0	77.0
17.0	32.0	16	41.0	80.0
18.0	35.0	16	41.0	80.0
19.0	38.0	16	44.5	83.5
20.0	38.0	16	44.5	83.5
21.0	38.0	25	42.5	95.0
22.0	41.5	25	46.0	98.5
23.0	41.5	25	46.0	98.5
24.0	41.5	25	46.0	98.5
25.0	44.5	25	49.0	101.5
26.0	43.0	25	49.0	101.5
28.0	46.0	25	52.0	104.5
30.0	46.0	25	52.0	104.5
32.0	49.0	25	55.5	108.0
34.0	49.0	25	55.5	108.0
35.0	52.5	25	58.5	111.0
36.0	52.5	25	58.5	111.0
38.0	55.5	25	62.0	114.5
40.0	58.5	25	65.0	117.5
42.0	60.5	25	65.0	117.5
44.0	63.5	25	68.0	120.5
45.0	63.5	25	68.0	120.5

Range of Application:
For end milling operation

**High Speed Steel
SCREWED SHANK END MILLS
SHORT SERIES (Normal Series)**



Diameter	Cutting edge length	Shank Diameter	Nominal Length below Chuck	Overall Length
1/8	3/8	1/4	21/32	2.1/8
5/32	1/2	1/4	25/32	2.1/4
3/16	1/2	1/4	25/32	2.1/4
7/32	5/8	1/4	29/32	2.3/8
1/4	5/8	1/4	29/32	2.3/8
9/32	19/32	3/8	7/8	2.3/8
5/16	23/32	3/8	1	2.1/2
11/32	27/32	3/8	1.1/8	2.5/8
3/8	27/32	3/8	1.1/8	2.5/8
13/32	7/8	3/8	1.1/8	2.5/8
7/16	3/4	1/2	1.1/8	2.5/8
15/32	7/8	1/2	1.1/4	2.3/4
1/2	15/16	1/2	1.1/4	2.3/4
9/16	1.1/8	1/2	1.3/8	2.7/8
5/8	1.1/16	5/8	1.1/2	3.1/32
11/16	1.3/8	5/8	1.5/8	3.5/32
3/4	1.1/2	5/8	1.3/4	3.9/32
13/16	1.1/2	1	1.11/16	3.3/4
7/8	1.5/8	1	1.13/16	3.7/8
15/16	1.5/8	1	1.13/16	3.7/8
1	1.11/16	1	1.15/16	4
1.1/16	1.11/16	1	1.15/16	4
1.1/8	1.13/16	1	2.1/16	4.1/8
1.3/16	1.13/16	1	2.1/16	4.1/8
1.1/4	1.15/16	1	2.3/16	4.1/4
1.5/16	1.15/16	1	2.3/16	4.1/4
1.3/8	2.1/16	1	2.5/16	4.3/8
1.7/16	2.1/16	1	2.5/16	4.3/8
1.1/2	2.3/16	1	2.7/16	4.1/2
1.5/8	2.3/8	1	2.9/16	4.5/8
1.3/4	2.1/2	1	2.11/16	4.3/4
1.7/8	2.5/8	1	2.13/16	4.7/8
2	2.3/4	1	2.15/16	5

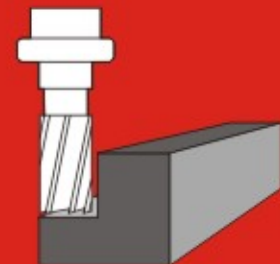

Dimensions in inches
Specifications conform to:
BS:122 Part 4 : 1980

MILLING CUTTERS

Range of Application:
For end milling operation



MILLING CUTTERS

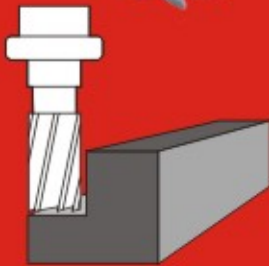

Dimensions in mm
Specifications conform to:
BS:122 Part 4 : 1980

High Speed Steel SCREWED SHANK END MILLS (Long Series)

Diameter	Cutting edge length	Shank Diameter	Nominal Length below Chuck	Overall Length
3.0	19.0	6	26.0	63.5
3.5	25.5	6	32.5	70.0
4.0	25.5	6	32.5	70.0
4.5	25.5	6	32.5	70.0
5.0	31.5	6	38.5	76.0
5.5	31.5	6	38.5	76.0
6.0	31.5	6	38.5	76.0
6.5	35.0	10	41.5	79.5
7.0	34.0	10	41.5	79.5
7.5	34.0	10	41.5	79.5
8.0	34.0	10	41.5	79.5
8.5	37.0	10	44.5	82.5
9.0	37.0	10	44.5	82.5
10.0	37.0	10	44.5	82.5
11.0	41.5	12	51.0	89.0
12.0	49.5	12	57.0	95.0
13.0	50.0	12	57.0	95.0
14.0	57.0	12	63.5	101.5
15.0	58.5	16	69.5	108.5
16.0	58.5	16	69.5	108.5
17.0	67.0	16	76.0	115.0
18.0	70.0	16	76.0	115.0
19.0	76.0	16	82.5	121.5
20.0	76.0	16	82.5	121.5
22.0	85.5	25	90.5	143.0
24.0	92.0	25	96.5	149.0
25.0	100.0	25	104.5	157.0
26.0	98.5	25	104.5	157.0
28.0	98.5	25	104.5	157.0
30.0	98.5	25	104.5	157.0
32.0	100.0	25	106.5	159.0
34.0	100.0	25	106.5	159.0
35.0	100.0	25	106.5	159.0
36.0	100.0	25	106.5	159.0
38.0	100.0	25	106.5	159.0
40.0	101.5	25	106.5	159.0
45.0	101.5	25	106.5	159.0

Range of Application:
For end milling operation

**High Speed Steel
SCREWED SHANK END MILLS
(Long Series)**



Diameter	Cutting edge length	Shank Diameter	Nominal Length below Chuck	Overall Length
1/8	3/4	1/4	1.1/32	2.1/2
5/32	1	1/4	1.9/32	2.3/4
3/16	1	1/4	1.9/32	2.3/4
7/32	1.1/4	1/4	1.17/32	3
1/4	1.1/4	1/4	1.17/32	3
9/32	1.11/32	3/8	1.5/8	3.1/8
5/16	1.11/32	3/8	1.5/8	3.1/8
11/32	1.15/32	3/8	1.3/4	3.1/4
3/8	1.15/32	3/8	1.3/4	3.1/4
13/32	1.1/2	3/8	1.3/4	3.1/4
7/16	1.5/8	1/2	2	3.1/2
15/32	1.7/8	1/2	2.1/4	3.3/4
1/2	1.15/16	1/2	2.1/4	3.3/4
9/16	2.1/4	1/2	2.1/2	4
5/8	2.5/16	5/8	2.3/4	4.9/32
11/16	2.3/4	5/8	3	4.17/32
3/4	3	5/8	3.1/4	4.25/32
13/16	3.1/16	1	3.5/16	5.3/8
7/8	3.3/8	1	3.9/16	5.5/8
15/16	3.5/8	1	3.13/16	5.7/8
1	3.15/16	1	4.1/8	6.3/16
1.1/16	3.7/8	1	4.1/8	6.3/16
1.1/8	3.7/8	1	4.1/8	6.3/16
1.3/16	3.7/8	1	4.1/8	6.3/16
1.1/4	3.15/16	1	4.3/16	6.1/4
1.5/16	3.15/16	1	4.3/16	6.1/4
1.3/8	3.15/16	1	4.3/16	6.1/4
1.7/16	3.15/16	1	4.3/16	6.1/4
1.1/2	3.15/16	1	4.3/16	6.1/4
1.5/8	4	1	4.3/16	6.1/4
1.3/4	4	1	4.3/16	6.1/4
1.7/8	4	1	4.3/16	6.1/4
2	4	1	4.3/16	6.1/4

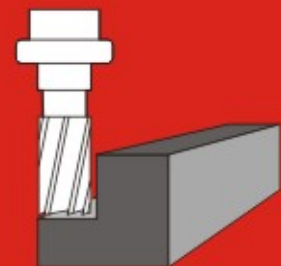

Dimensions in inches
Specifications conform to:
BS:122 Part 4 : 1980

MILLING CUTTERS

Range of Application:
For end milling operation



MILLING CUTTERS



Dimensions in mm
Specifications conform to
IS 2668 : 2004
ISO 3337 : 2000

High Speed Steel T-SLOT CUTTERS (With Parallel Shank)

Nominal size of T-Slot	Diameter of cutter (h12)	Width of cutter (h12)	Shank diameter (h8)	Overall length
10	18	8	12	70
12	21	9	12	74
14	25	11	16	82
18	32	14	16	90
22	40	18	25	108
28	50	22	32	124
36	60	28	32	139

Normally RH cutting and Type N tools are supplied.

Range of Application:

For opening out the bottom of previously milled slot to form 'T'-slot

**High Speed Steel
T-SLOT CUTTERS
(With Taper Shank - Tapped End)**



Nominal size of T-slot	Diameter of cutter (h12)	Width of cutter (h12)	Overall Length	MT Shank	
				No	Thread size of tapped hole
10	18	8	82	1	M6
12	21	9	98	2	M10
14	25	11	103	2	M10
18	32	14	111	2	M10
22	40	18	138	3	M12
28	50	22	173	4	M16
36	60	28	188	4	M16
42	72	35	229	5	M20
48	85	40	240	5	M20
54	95	44	251	5	M20

Normally RH cutting and Type N tools are supplied.



MILLING CUTTERS

Dimensions in mm
Specifications conform to
IS 2668 : 2004
ISO 3337 : 2000

Range of Application:
For opening out the bottom of previously milled slot to form 'T'-slot



MILLING CUTTERS



Dimensions in inches
Specifications conform to
BS 122 Part 1 : 1989

High Speed Steel 'T' SLOT CUTTER WITH TAPER SHANK (TAPPED END)

Nominal size of T-slot	Diameter of cutter +0.0 -0.010	Width of cutter +0.0 0.005*	Overall Length	MT Shank	
				No	Thread size of tapped hole
1/4	37/64	1/4	3.9/16	2	3/8 BSW
5/16	45/64	5/16	3.3/4	2	3/8 BSW
3/8	53/64	23/64	3.7/8	2	3/8 BSW
7/16	61/64	27/64	4.1/16	2	3/8 BSW
1/2	1.5/64	15/32	4.3/16	2	3/8 BSW
5/8	1.21/64	37/64	5.1/8	3	1/2 BSW
3/4	1.33/64	11/16	5.7/16	3	1/2 BSW
7/8	1.45/64	51/64	5.3/4	3	1/2 BSW
1	1.61/64	29/32	7.1/16	4	5/8 BSW
1.1/8	2.1/8	1.1/16	7.1/8	4	5/8 BSW
1.1/4	2.5/16	1.3/16	7.3/8	4	5/8 BSW
1.3/8	2.1/2	1.5/16	8.7/8	5	5/8 BSW
1.1/2	2.3/4	1.7/16	9.1/8	5	5/8 BSW

Normally RH cutting and Type N tools are supplied

Range of Application:

For opening out the previously milled slot to form 'T' - slot

**High Speed Steel
DOVE - TAIL MILLING CUTTERS**



Angle	Diameter	Shank Diameter	Overall Length	Width	Type
45°	16	12	60	4	A&B
45°	20	12	63	5	
45°	25	12	67	6.3	
45°	31.5	16	71	8	
50°	16	12	60	5	A
50°	20	12	63	6.3	
50°	25	12	67	8	
50°	31.5	16	71	10	
55°	16	12	60	5.6	A
55°	20	12	63	7.1	
55°	25	12	67	9	
55°	31.5	16	71	11.2	
60°	16	12	60	6.3	A&B
60°	20	12	63	8	
60°	25	12	67	10	
60°	31.5	16	71	12.5	

Type A: Dove - Tail Milling Cutter with plain parallel shank
 Type B: Inverse Dove - Tail Milling Cutter with plain parallel shank
 Normally RH cutting and Type N tools are supplied



Dimensions in mm
 Specifications conform to:
 IS:6255 : 2000
 ISO:3859 : 1977
 DIN:1833 (Tail 1) : 1983

MILLING CUTTERS

Range of Application:
 To produce dove-tail slot in machine beds.



High Speed Steel WOODRUFF KEY SLOT MILLING CUTTERS PARALLEL SHANK

Diameter (h11)	Width (e8)	Shank dia	Overall length	Woodruff key to IS:2294
10.5	2	6	50	2x3.7
10.5	2.5	6	50	2.5x3.7
10.5	3	6	50	3.x3.7
13.5	3	10	56	3x5
13.5	4	10	56	4x5
16.5	3	10	56	3x6.5
16.5	4	10	56	4x6.5
16.5	5	10	56	5x6.5
19.5	4	10	56	4x7.5
19.5	5	10	56	5x7.5
19.5	6	10	63	6x7.5
22.5	5	10	63	5x9
22.5	6	10	63	6x9
22.5	8	10	63	8x9
25.5	6	10	63	6x10
28.5	6	10	63	6x11
28.5	8	10	63	8x11
28.5	10	12	71	10x11
32.5	8	10	63	8x13
32.5	10	12	71	10x13
45.5	10	12	71	10x16

Normally straight teeth, RH cutting and Type N tools are supplied

Type A - Straight Teeth and
Type B - Staggered Teeth



Dimensions in mm
Specifications conform to
IS 2669 : 2001

MILLING CUTTERS

Range of Application:
For milling seat to suit woodruff keys

**High Speed Steel
WOODRUFF KEY SLOT MILLING CUTTERS
PARALLEL SHANK**



BS Cutter and Key no	Diameter of cutter +0.010 -0.0	Width Cutter +0.001 -0.0	Overall length	Shank Diameter
204	0.505	0.061	2	1/2
304	0.505	0.093	2	1/2
404	0.505	0.124	2	1/2
305	0.63	0.093	2	1/2
405	0.63	0.124	2	1/2
505	0.63	0.155	2	1/2
406	0.755	0.124	2.1/4	1/2
506	0.755	0.155	2.1/4	1/2
606	0.755	0.187	2.1/4	1/2
507	0.88	0.155	2.1/2	1/2
607	0.88	0.187	2.1/2	1/2
807	0.88	0.249	2.1/2	1/2
608	1.005	0.187	2.3/4	1/2
808	1.005	0.249	2.3/4	1/2
1008	1.005	0.311	2.3/4	1/2
609	1.13	0.187	2.3/4	1/2
809	1.13	0.249	2.3/4	1/2
1009	1.13	0.311	2.3/4	1/2
810	1.255	0.249	2.3/4	1/2
1010	1.255	0.311	2.3/4	1/2
1210	1.255	0.374	2.3/4	1/2
1011	1.38	0.311	3	1/2
1211	1.38	0.374	3	1/2
812	1.38	0.249	3	1/2
1012	1.505	0.311	3	1/2
1212	1.505	0.374	3	1/2

Normally straight teeth, RH cutting and Type N tools are supplied



Dimensions in Inches
Specifications conform to:
BS 122 Part 1 : 1989

MILLING CUTTERS

Range of Application:
For milling seat to suit woodruff keys



MILLING CUTTERS



Dimensions are in mm
Specifications conform to:
IS 5693 : 2002
ISO 4205 : 1991
BS 328 Part 6 : 1992
DIN 1866 : 1975

High Speed Steel COUNTERSINKS - 90° With Parallel Shank & Solid Pilot

Diameter (z9)		Pilot Diameter (e8)	Shank Dia (h9) Cutting	Cutting Edge Length	Shank Length	Overall Length
Over	Up to &					
5	8	To be specified to suit pilot diameter when ordering	5	14	31.5	71
8	12.5		8	18	35.5	80
12.5	20		12.5	22	40	100

These cutters have RH helical flutes for RH cutting

Range of Application:

To produce counter sunk seat for cheese head screw

**High Speed Steel
COUNTERSINKS - 90°
WITH MORSE TAPER SHANK AND
DETACHABLE PILOT**



Diameter (z9)		Pilot Diameter (e8)		Pilot hole Diameter (h8)	Set Screw Dia	Cone Dia	Overall Length	Cutting Edge Length	MT Shank no
Over	Up to & including	Over	Up to & including						
12.5	16	6.3	14	4	M3	6	132	22	2
16	20	6.3	18	5	M4	6	140	25	2
20	25	8	22.4	6	M5	7.5	150	30	2
25	31.50	10	28	8	M6	9.5	180	35	3
31.5	40	12.5	35.5	10	M8	12	190	40	3

These Cutters have RH helical flutes for RH cutting



Dimensions in mm
Specifications conform to:
IS 5703 : 2002
ISO 4204 : 1977
DIN 1867 : 1975

MILLING CUTTERS

Range of Application:

To produce counter sunk seat for cheese head screw



MILLING CUTTERS

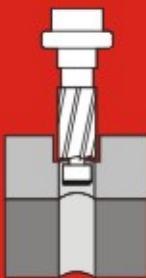

Dimensions in mm
Specifications conform to:
IS 5704 : 2002
ISO 4206 : 1977
DIN 373 : 1975

High Speed Steel COUNTERBORES With Parallel Shank & Solid Pilot

Diameter (z9)		Pilot Diameter (e8)	Shank Dia (h9)	Overall Length	Shank Length	Cutting Edge
Over	Up to &					
3.15	5	To be specified to suit pilot diameter when ordering		56		10
5	8		5	71	31.5	14
8	12.5		5	80	35.5	18
12.5	20		12.5	100	40	22

Normally RH helical flutes and Type N tools are supplied

**High Speed Steel
COUNTER BORE WITH MORSE TAPER
SHANK AND DETACHABLE PILOT**



Diameter (z9)		Pilot Diameter e8		Pilot hole Diameter H8	Set Screw Size	Cutting Edge Length	Overall Length	MT Shank no
Over	Up to & including	Over	Up to & including					
12.5	16	5.0	14	4	M3	22	132	2
16	20	6.3	18	5	M4	25	140	2
20	25	8	22.4	6	M5	30	150	2
25	31.5	10	28	8	M6	35	180	3
31.5	40	12.5	35.5	10	M8	40	190	3
40	50	16	45	12	M8	50	236	4
50	63	20	56	16	M10	63	250	4

Normally RH helical flutes and Type N tools are supplied



Dimensions in mm
Specifications conform to:
IS 5710 : 2002
ISO 4207 : 1977
BS 328 Part 5 : 1991
DIN 375 : 1975

MILLING CUTTERS

Range of Application:
To produce counter sunk seat for socket head screw



MILLING CUTTERS



Dimensions in mm
Specifications conform to:
IS 13304 : 2002
ISO 3294 : 1975
DIN 334 : 1979
DIN 335 : 1979
DIN 347 : 1962

High Speed Steel COUNTERSINKS With Included Angle 60°, 90° & 120° (Parallel Shank)

Nominal size	Small Dia	Overall Length		Body Length		MT Shank No.
		60°	90° & 120°	60°	90° & 120°	
8	1.6	48	44			8
10	2	50	46	18	14	8
12.5	2.5	52	48	20	16	8
16	3.2	60	56	24	20	10
20	4	64	60	28	24	10
25	7	69	65	33	29	10

These Cutters have RH helical flute for RH cutting

Range of Application:

To produce countersunk seat suitable for countersink head screws,
also use as a deburring tool.

**High Speed Steel
COUNTERSINKS**
With Included Angle 60°, 90° & 120°
(Taper Shank)



Nominal size	Small Dia	Overall Length		Body Length		MT Shank No.
		60°	90° & 120°	60°	90° & 120°	
16	3.2	97	93	24	20	1
20	4	120	116	28	24	2
25	7	125	121	33	29	2
31.5	9	132	124	40	32	2
40	12.5	160	150	45	35	3
50	16	165	153	50	38	3
63	20	200	185	58	43	4
80	25	215	196	73	54	4

These countersinks have straight flutes for RH cutting



Dimensions in mm
Specifications conform to:
IS 13303 : 2002
ISO 3294 : 1975
DIN 334 : 1979
DIN 335 : 1979
DIN 347 : 1962

Range of Application:

To produce countersunk seat suitable for countersink head screws,
also use as a deburring tool.

MILLING CUTTERS



MILLING CUTTERS



Dimensions in inches
Specifications conform to
BS 122 Part 1 : 1989

High Speed Steel COUNTERSINKS With included angle 60°,80°,90° &120° (Taper Shank)

Body Diameter	Overall length	Small Dia	Morse Taper no
1/2	3.1/2	5/32	1
5/8	3.5/8	3/16	1
3/4	4.1/4	1/4	2
7/8	4.1/4	9/32	2
1	4.3/8	5/16	2
1.1/8	4.1/2	3/8	2
1.1/4	5.3/8	13/32	3
1.3/8	5.3/8	7/16	3
1.1/2	5.1/2	1/2	3
1.3/4	6.3/4	9/16	4
2	7	21/32	4
2.1/4	7.1/4	3/4	4
2.1/2	7.3/4	13/16	4
2.3/4	8	7/8	4
3	8.1/8	1	4

Tolerance -
1 inch and below = -0.001
-0.003
Above 1 inch = -0.002
-0.005

These countersinks have straight flutes for RH cutting

Range of Application:

To produce countersunk seat suitable for countersink head screws,
also use as a deburring tool.



TECHNICAL SUPPLY CONDITIONS OF “DAGGER MILLING CUTTERS”

1. Milling cutters are normally supplied for RH cutting and Tool Type N.
2. Intermediate diameters, if ordered, shall be supplied with the same dimensions as the next larger standard size.
3. Non standard or special cutters are manufactured against specific orders.
4. Bore of milling cutters is usually supplied with H7 tolerance and the shank tolerance as specified in the BIS/ ISO.
5. Cutters with Taper shank are normally supplied with Morse taper according to IS: 1715 – Dimensions of Self holding Tapers
- 5.1 Dimensions for parallel shanks shall be according to IS: 8692 – Dimensions for parallel shanks for milling
6. Other general requirements are maintained according to IS: 1830 – Technical supply conditions for milling cutters

6.1 Hardness:

Cutting portion:	760 HV to 900 HV
Shank Portion:	
Parallel shank:	240 HV to equal to cutting portion (In case of one-piece construction) 185 HV to 450 HV (In case of two piece construction)
Morse taper shank:	185HV min (after construction)
Tang of Morse Taper Shank:	300 HV to 450 HV

6.2 Radial and Axial run out

Type of Cutter	Diameter range		Permissible Radial and Axial Run out		Testing conditions
	Over	Upto and including	Form relieved	Profile Sharpened	
Cutter with bore	-	50	0.07	0.05	Rotated on Stationary test arbor
	50	120	0.10	0.07	
	120	250	0.12	0.10	
Cutter with Shank	-	50	0.07	0.05	Held between centres or shank rotated in a 'V' - block
	50	120	0.10	0.07	

7. Recommendation for Tool Type selection of milling cutters:
 - Tool Type N – For mild steel, malleable cast iron and medium hard non-ferrous metals.
 - Tool Type H – For specially hard and tough materials
 - Tool Type S – For soft and ductile materials.



Basic Geometry for Machining Normal Materials – Carbon Steels & Cast Iron

Type of Tool	Helix angle	Positive rake	Primary Clearance
Cylindrical milling cutter	30° - 35° R.H.	8° - 12°	7° - 9°
Side & Face milling cutter	Straight teeth	6° - 10°	4° - 6°
Shell end mill	25° - 30° R.H.	8° - 12°	
Equal angle milling cutter	-	0°	3° - 5°
Woodruff key slot milling cutter	Straight teeth	3° - 5°	3° - 5°
Slot milling cutter with parallel shank	15° - 20° R.H	4° - 6°	2° - 4°
End mills with parallel shank	27° - 33° R.H	9° - 11°	8° - 12°
End mills with Mors		9° - 11°	8° - 12°
T - slot milling cutter with Morse taper shank	12° - 18° L.H. & R.H	6° - 10°	4° - 6°
e taper shank (Tapped end)	27° - 33° R.H	Alternatively	

Recommended Cutting Fluids For HSS Milling Cutters

Type of Material	Recommendations
Hard tool and alloy steel	Soluble oil compound or neat cutting oil
Low carbon steel	Soluble oil
Copper, brass or bronze	Soluble oil or dry
Aluminium and Aluminium alloys	Soluble oil or neat cutting oil specially produced for light alloys
Magnesium	Dry or Compressed air
Cast iron	Dry or Compressed air
Stainless Steel Nimonic alloys	Soluble oil can be used but sulphurised or chlorinated mineral oil or fatty oil are most suitable.
Zinc base alloys	Soluble oil



CUTTING SPEEDS (m/ min)

Material	Plain milling cutter	Shell end mill	Side milling cutter	End mill	Form relieved cutter
Unalloyed Steel up to 70 kg/mm ²	25 - 35	25 - 35	25 - 35	25 - 35	25 - 30
Steel up to 90 kg/mm ²	20 - 30	20 - 30	20 - 30	20 - 30	15 - 25
Cast Iron, Alloy steel up to 100 kg/mm ²	15 - 25	15 - 25	15 - 25	15 - 25	12 - 20
Copper, brass, red brass	40 - 60	40 - 60	40 - 60	40 - 60	30 - 50
Cast bronze, bronze	30 - 50	30 - 50	30 - 50	30 - 50	25 - 40
Aluminium long chipped	250 - 300	300 - 400	300 - 400	300 - 400	300 - 400
Tough aluminium alloys, Aluminium cast alloys, Magnesium alloys	200 - 300	250 - 350	200 - 250	250 - 350	200 - 300
Age- hardened aluminium alloys, brittle aluminium alloys	150 - 200	200 - 250	150 - 200	200 - 250	150 - 200

FEEDS PER TOOTH (mm)

Material	Plain milling cutter	Shell end mill	Side milling cutter	End mill	Form relieved cutter
Unalloyed Steel up to 70 kg/mm ²	0.2	0.25	0.07	0.05	0.04
Steel up to 90 kg/mm ²	0.1	0.15	0.06	0.03	0.03
Alloy steel up to 100 kg/mm ²	0.08	0.1	0.05	0.02	0.02
Copper, brass, red brass	0.2	0.25	0.08	0.05	0.04
Bronze	0.15	0.2	0.06	0.04	0.03
Aluminium long chipped	0.15	0.2	0.07	0.05	0.04
Tough aluminium alloys, Aluminium cast alloys, Magnesium alloys	0.1	0.15	0.06	0.04	0.03
Age- hardened aluminium alloys, brittle aluminium alloys	0.05	0.08	0.05	0.03	0.03



Recommendations for SELECTION OF MILLING CUTTERS (Ref: IS 1830)

Material to be cut	Tensile strength MN/ m ²	Brinell HardnessHB	Tool Type
Carbon steel	Up to 500		N or (S)
	Above 500 up to 800		N
	Above 800 up to 1000		N or (H)
	Above 1000 up to 1300		H
Steel castings			H
Grey cast iron		Up to 180	N
		Over 180	H
Malleable cast iron			N
Copper Alloy	Soft		S or (N)
	Brittle		N or (H)
Zinc alloy			S or (N)
Aluminium alloy	Soft		S
	Medium		N or (S)
	Hard		N or (S)
Aluminium alloy age hardened	Low cutting speed		N
	High cutting speed		S
Magnesium alloy			S or (N)
Plastics	Unlaminated		N or (S)
	Laminated		S

Tool Type N – For mild steel, Malleable Cast iron and medium hard non – ferrous metals

Tool Type H – For Specially hard and tough materials

Tool Type S – For Soft and ductile materials

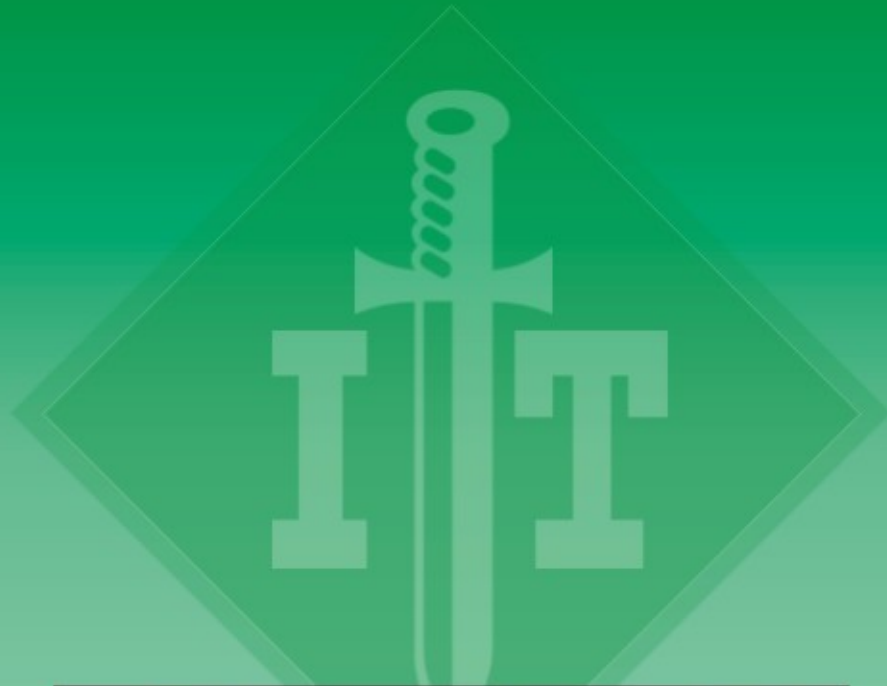



Elements of a Screwing Tap and Related terms

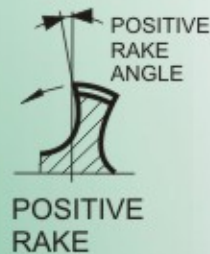
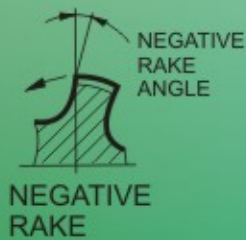
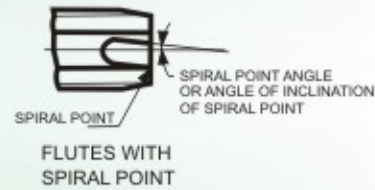
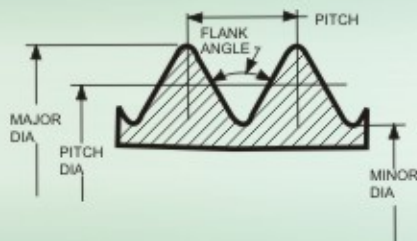
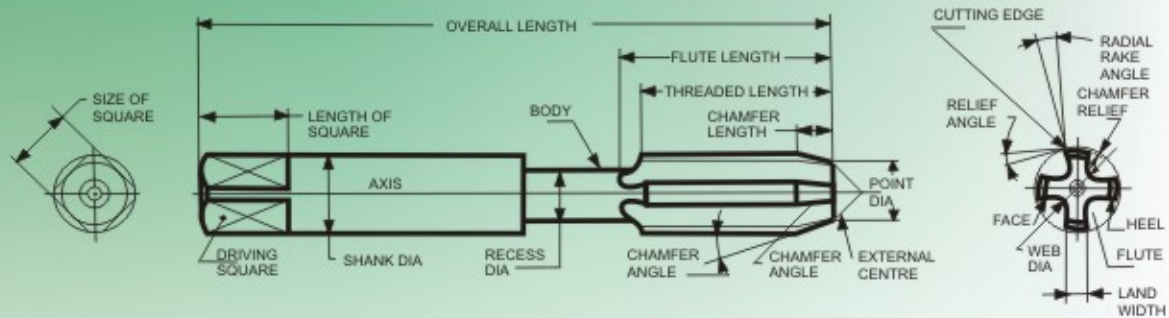

**High Speed Steel
HAND AND SHORT MACHINE TAPS
ISO METRIC-GROUND THREADS
COARSE PITCH**



Nominal diameter	Pitch	Thread Length	Overall Length	Shank diameter (h9)	Square	
					Size (h11)	Length
M3	0.50	11.0	48.0	3.15	2.50	5
M3.5	0.60	13.0	50.0	3.55	2.80	5
M4	0.70	13.0	53.0	4.00	3.15	6
M4.5	0.75	13.0	53.0	4.50	3.55	6
M5	0.80	16.0	58.0	5.00	4.00	7
M6	1.00	19.0	66.0	6.30	5.00	8
M7	1.00	19.0	66.0	7.10	5.60	8
M8	1.25	22.0	72.0	8.00	6.30	9
M9	1.25	22.0	72.0	9.00	7.10	10
M10	1.50	24.0	80.0	10.00	8.00	11

These Taps are supplied in a set of Three Taper, Second, & bottoming non serial with thread Tolerance-6H.



SCREWING TAPS

Dimensions in mm
Specifications conform to:
IS: 6175 Part 2 : 2002
ISO 529 : 1975
BS 949 Part 1 : 1992

Range of Application
General Purpose Tapping



SCREWING TAPS



High Speed Steel HAND AND SHORT MACHINE TAPS ISO METRIC-GROUND THREADS FINE PITCH

Nominal diameter	Pitch	Thread Length	Overall Length	Shank diameter (h9)	Square	
					Size (h11)	Length
M3	0.35	11	48	3.15	2.50	5
M3.5	0.35	13	50	3.55	2.80	5
M4	0.50	13	53	4.00	3.15	6
M4.5	0.50	13	53	4.50	3.55	6
M5	0.50	16	58	5.00	4.00	7
M5.5	0.50	17	62	5.60	4.50	7
M6	0.75	19	66	6.30	5.00	8
M7	0.75	19	66	7.10	5.60	8
M8	0.75	16	66	8.00	6.30	9
M8	1.00	19	69	8.00	6.30	9
M9	0.75	16	66	9.00	7.10	10
M9	1.00	19	69	9.00	7.10	10
M10	0.75	17	73	10.00	8.00	11
M10	1.00	20	76	10.00	8.00	11
M10	1.25	20	76	10.00	8.00	11

These Taps are supplied in a set of Two Taper & bottoming non serial with thread Tolerance-6H.

Dimensions in mm
Specifications conform to:
IS: 6175 Part 2 : 2002
ISO 529 : 1975
BS 949 Part 1 : 1992

**High Speed Steel
HAND AND SHORT MACHINE TAPS
ISO Metric Ground Threads Coarse Pitch**



Nominal diameter	Pitch	Thread Length	Overall Length	Shank diameter (h9)	Square	
					Size (h11)	Length
M3	0.50	11	48	2.24	1.80	4
M3.5	0.60	13	50	2.50	2.00	4
M4	0.70	13	53	3.15	2.50	5
M4.5	0.75	13	53	3.55	2.80	5
M5	0.80	16	58	4.00	3.15	6
M6	1.00	19	66	4.50	3.55	6
M7	1.00	19	66	5.60	4.50	7
M8	1.25	22	72	6.30	5.00	8
M9	1.25	22	72	7.10	5.60	8
M10	1.50	24	80	8.00	6.30	9
M11	1.50	25	85	8.00	6.30	9
M12	1.75	29	89	9.00	7.10	10
M14	2.00	30	95	11.20	9.00	12
M16	2.00	32	102	12.50	10.00	13
M18	2.50	37	112	14.00	11.20	14
M20	2.50	37	112	14.00	11.20	14
M22	2.50	38	118	16.00	12.50	16
M24	3.00	45	130	18.00	14.00	18
M25	3.00	45	130	20.00	16.00	20
M27	3.00	45	135	20.00	16.00	20
M30	3.50	48	138	20.00	16.00	20
M33	3.50	51	151	22.40	18.00	22
M36	4.00	57	162	25.00	20.00	24
M39	4.00	60	170	28.00	22.40	26
M42	4.50	60	170	28.00	22.40	26
M45	4.50	67	187	31.50	25.00	28
M48	5.00	67	187	31.50	25.00	28
M52	5.00	70	200	35.50	28.00	31
M56	5.50	70	200	35.50	28.00	31
M60	5.50	76	221	40.00	31.50	34
M64	6.00	79	224	40.00	31.50	34
M68	6.00	79	234	45.00	35.50	38

These taps are supplied in set of three Taper, second & bottoming non serial with thread tolerance - 6H.



SCREWING TAPS

Dimensions in mm
Specification conform to :
IS : 6175 Part 3 : 2002
ISO 529 : 1975
BS 949 Part : 1992

Range of Application:
General Purpose Tapping



SCREWING TAPS



Dimensions in mm
 Specifications conform to:
 IS : 6175 Part 3 : 2002
 ISO 529 : 1975
 BS 949 Part 1 : 1992

High Speed Steel HAND AND SHORT MACHINE TAPS ISO Metric Ground Threads Fine Pitch

Nominal diameter	Pitch	Thread Length	Overall Length	Shank diameter (h9)	Square	
					Size (h11)	Length
M3	0.35	11	48	2.24	1.80	4
M3.5	0.35	13	50	2.50	2.00	4
M4	0.50	13	53	3.15	2.50	5
M4.5	0.50	13	53	3.55	2.80	5
M5	0.50	16	58	4.00	3.15	6
M5.5	0.50	17	62	4.00	3.15	6
M6	0.75	19	66	4.50	3.55	6
M7	0.75	19	66	5.60	4.50	7
M8	0.75	16	66	6.30	5.00	8
M8	1.00	19	69	6.30	5.00	8
M9	0.75	16	66	7.10	5.60	8
M9	1.00	19	69	7.10	5.60	8
M10	0.75	17	73	8.00	6.30	9
M10	1.00	20	76	8.00	6.30	9
M10	1.25	20	76	8.00	6.30	9
M11	0.75	20	80	8.00	6.30	9
M11	1.00	20	80	8.00	6.30	9
M12	1.00	20	80	9.00	7.10	10
M12	1.25	24	84	9.00	7.10	10
M12	1.50	29	89	9.00	7.10	10
M14	1.00	22	87	11.20	9.00	12
M14	1.25	25	90	11.20	9.00	12
M14	1.50	30	95	11.20	9.00	12
M15	1.00	22	87	11.20	9.00	12
M15	1.50	30	95	11.20	9.00	12
M16	1.00	22	92	12.50	10.00	13
M16	1.50	32	102	12.50	10.00	13
M17	1.00	22	92	12.50	10.00	13
M17	1.50	32	102	12.50	10.00	13
M18	1.00	22	97	14.00	11.20	14
M18	1.50	29	104	14.00	11.20	14
M18	2.00	37	112	14.00	11.20	14
M20	1.00	27	102	14.00	11.20	14
M20	1.50	29	104	14.00	11.20	14
M20	2.00	37	112	14.00	11.20	14
M22	1.00	29	109	16.00	12.50	16
M22	1.50	33	113	16.00	12.50	16
M22	2.00	38	118	16.00	12.50	16
M24	1.00	29	114	18.00	14.00	18
M24	1.50	35	120	18.00	14.00	18
M24	2.00	35	120	18.00	14.00	18
M25	1.00	29	114	18.00	14.00	18
M25	1.50	35	120	18.00	14.00	18
M25	2.00	35	120	18.00	14.00	18
M26	1.50	35	120	18.00	14.00	18
M27	1.00	30	120	20.00	16.00	20
M27	1.50	37	127	20.00	16.00	20
M27	2.00	37	127	20.00	16.00	20

Range of Application:
 General Purpose Tapping

High Speed Steel
HAND AND SHORT MACHINE TAPS
ISO Metric Ground Threads Fine Pitch



Nominal diameter	Pitch	Thread Length	Overall Length	Shank diameter (h9)	Square	
					Size (h11)	Length
M28	1.00	30	120	20.00	16.00	20
M28	1.50	37	127	20.00	16.00	20
M28	2.00	37	127	20.00	16.00	20
M30	1.00	30	120	20.00	16.00	20
M30	1.50	37	127	20.00	16.00	20
M30	2.00	37	127	20.00	16.00	20
M30	3.00	48	138	20.00	16.00	20
M32	1.50	37	137	22.40	18.00	22
M32	2.00	37	137	22.40	18.00	22
M33	1.50	37	137	22.40	18.00	22
M33	2.00	37	137	22.40	18.00	22
M33	3.00	51	151	22.40	18.00	22
M35	1.50	39	144	25.00	20.00	24
M36	1.50	39	144	25.00	20.00	24
M36	2.00	39	144	25.00	20.00	24
M36	3.00	57	162	25.00	20.00	24
M38	1.50	39	149	28.00	22.40	26
M39	1.50	39	149	28.00	22.40	26
M39	2.00	39	149	28.00	22.40	26
M39	3.00	60	170	28.00	22.40	26
M40	1.50	39	149	28.00	22.40	26
M40	2.00	39	149	28.00	22.40	26
M40	3.00	60	170	28.00	22.40	26
M42	1.50	39	149	28.00	22.40	26
M42	2.00	39	149	28.00	22.40	26
M42	3.00	60	170	28.00	22.40	26
M42	4.00	60	170	28.00	22.40	26
M45	1.50	45	165	31.50	25.00	28
M45	2.00	45	165	31.50	25.00	28
M45	3.00	67	187	31.50	25.00	28
M45	4.00	67	187	31.50	25.00	28
M48	1.50	45	165	31.50	25.00	28
M48	2.00	45	165	31.50	25.00	28
M48	3.00	67	187	31.50	25.00	28
M48	4.00	67	187	31.50	25.00	28
M50	1.50	45	165	31.50	25.00	28
M50	2.00	45	165	31.50	25.00	28
M50	3.00	67	187	31.50	25.00	28
M52	1.50	45	175	35.50	28.00	31
M52	2.00	45	175	35.50	28.00	31
M52	3.00	70	200	35.50	28.00	31
M52	4.00	70	200	35.50	28.00	31
M55	1.50	45	175	35.50	28.00	31
M55	2.00	45	175	35.50	28.00	31
M55	3.00	70	200	35.50	28.00	31
M55	4.00	70	200	35.50	28.00	31
M56	1.50	45	175	35.50	28.00	31
M56	2.00	45	175	35.50	28.00	31

Range of Application:
 General Purpose Tapping



Dimensions in mm
 Specification conform to :
 IS : 6175 Part 3 : 2002
 ISO 529 : 1975
 BS 949 Part : 1992

SCREWING TAPS



**High Speed Steel
TAPER PIPE HAND TAPS - BSPT
Ground thread**

Nominal size	Thread per inch	Basic or gauge dia. of thread	Diameter		Thread Length	Overall Length	Shank Dia.	Square	
			Large End	Small End (Before chamfering)				Size	Length
1/8	28	0.383	0.3986	0.3518	3/4	2.1/8	0.318	0.238	5/16
1/4	19	0.518	0.5336	0.4672	1.1/16	2.7/16	0.429	0.322	7/16
3/8	19	0.656	0.6716	0.6052	1.1/16	2.9/16	0.542	0.406	1/2
1/2	14	0.825	0.8484	0.7625	1.3/8	3.1/8	0.687	0.515	5/8
3/4	14	1.041	1.0644	0.9785	1.3/8	3.1/4	0.906	0.679	11/16
1	11	1.309	1.3402	1.2308	1.3/4	3.3/4	1.125	0.843	13/16
1.1/4	11	1.650	1.6812	1.5718	1.3/4	4	1.312	0.984	15/16
1.1/2	11	1.882	1.9132	1.8038	1.3/4	4.1/4	1.500	1.125	1
2	11	2.347	2.3782	2.2688	1.3/4	4.1/2	1.875	1.406	1.1/8
2.1/2	11	2.960	2.9951	2.8350	2.9/16	5.1/2	2.250	1.687	1.1/4
3	11	3.460	3.4951	3.3311	2.5/8	6	2.625	1.968	1.3/8
3.1/2	11	3.950	3.9890	3.8210	2.11/16	6.1/2	2.812	2.108	1.1/2
4	11	4.450	4.4890	4.3171	2.3/4	6.3/4	3.000	2.250	1.5/8

These Taps are supplied in a set of two Rougher and finisher in serial thread form



SCREWING TAPS

Dimensions in Inches
Specifications conform to:
BS 949 - 1969

**High Speed Steel
AMERICAN NATIONAL STRAIGHT PIPE
HAND TAPS - NPS
Ground Thread**



Nominal size	Thread per inch	Basic or gauge dia. Of thread	Thread Length	Overall Length	Shank Dia.	Square	
						Size	Length
1/16	27	0.3108	11/16	2.1/8	0.318	0.238	5/16
1/8	27	0.4044	3/4	2.1/8	0.318	0.238	5/16
1/4	18	0.5343	1.1/16	2.7/16	0.429	0.322	7/16
3/8	18	0.6714	1.1/16	2.9/16	0.542	0.406	1/2
1/2	14	0.8356	1.3/8	3.1/8	0.687	0.515	5/8
3/4	14	1.0460	1.3/8	3.1/4	0.906	0.679	11/16
1	11.1/2	1.3082	1.3/4	3.3/4	1.125	0.843	13/16
1.1/4	11.1/2	1.6530	1.3/4	4	1.312	0.984	15/16
1.1/2	11.1/2	1.8919	1.3/4	4.1/4	1.500	1.125	1
2	11.1/2	2.3658	1.3/4	4.1/2	1.875	1.406	1.1/8
2.1/2	8	2.8622	2.9/16	5.1/2	2.250	1.687	1.1/4
3	8	3.4885	2.5/8	6	2.625	1.968	1.3/8
3.1/2	8	3.9888	2.11/16	6.1/2	2.812	2.108	1.1/2
4	8	4.4871	2.3/4	6.3/4	3.000	2.250	1.5/8

These taps are supplied in a set of two - taper & bottoming.



SCREWING TAPS

Dimensions in Inches
Specifications conform to:
BS 949 1969

Range of Application:
For Tapping parallel Pipe threads



High Speed Steel AMERICAN NATIONAL TAPER PIPE HAND TAPS - NPT Ground Thread

Nominal size	Thread per inch	Basic or gauge dia. Of thread	Diameter		Thread Length	Overall Length	Shank Dia.	Square	
			Large End	Small End (Before chamfering)				Size	Length
1/16	27	0.3108	0.324	0.281	11/16	2.1/8	0.318	0.238	5/16
1/8	27	0.4044	0.420	0.373	3/4	2.1/8	0.318	0.238	5/16
1/4	18	0.5343	0.559	0.493	1.1/16	2.7/16	0.429	0.322	7/16
3/8	18	0.6714	0.694	0.628	1.1/16	2.9/16	0.542	0.406	1/2
1/2	14	0.8356	0.865	0.779	1.3/8	3.1/8	0.687	0.515	5/8
3/4	14	1.0460	1.075	0.989	1.3/8	3.1/4	0.906	0.679	11/16
1	11.1/2	1.3082	1.350	1.240	1.3/4	3.3/4	1.125	0.843	13/16
1.1/4	11.1/2	1.6530	1.393	1.584	1.3/4	4	1.312	0.984	15/16
1.1/2	11.1/2	1.8919	1.932	1.822	1.3/4	4.1/4	1.500	1.125	1
2	11.1/2	2.3658	2.405	2.297	1.3/4	4.1/2	1.875	1.406	1.1/8
2.1/2	8	2.8622	2.921	2.761	2.9/16	5.1/2	2.250	1.687	1.1/4
3	8	3.4885	3.547	3.383	2.5/8	6	2.625	1.968	1.3/8
3.1/2	8	3.9888	4.047	3.879	2.11/16	6.1/2	2.812	2.108	1.1/2
4	8	4.4871	4.547	4.375	2.3/4	6.3/4	3.000	2.250	1.5/8

These Taps are supplied in a set of two Rougher & Finisher in serial thread form



SCREWING TAPS

Dimensions in Inches
Specifications conform to:
BS 949 - 1969

High Speed Steel
AMERICAN NATIONAL TAPER PIPE HAND TAPS - NPT
Ground thread



Nominal diameter	Threads per inch	Thread Length	Overall Length	Shank diameter	Square	
					Size	Length
1/16	27	11/16	2.1/8	0.3125	0.234	3/8
1/8	27	3/4	2.1/8	0.4375	0.328	3/8
1/4	18	1.1/16	2.7/16	0.5625	0.421	7/16
3/8	18	1.1/16	2.9/16	0.7000	0.531	1/2
1/2	14	1.3/8	3.1/8	0.6875	0.515	5/8
3/4	14	1.3/8	3.1/4	0.9063	0.679	11/16
1	11.1/2	1.3/4	3.3/4	1.1250	0.843	13/16
1.1/4	11.1/2	1.3/4	4	1.3125	0.984	15/16
1.1/2	11.1/2	1.3/4	4.1/4	1.5000	1.125	1
2	11.1/2	1.3/4	4.1/2	1.8750	1.406	1.1/8

These Taps are supplied in a set of two Rougher & Finisher in serial thread form



SCREWING TAPS

Dimensions in Inches
 Specifications conform to:
 ANSI B 94.9 : 1971

Range of Application:
 For Tapping Taper Pipe threads



SCREWING TAPS



Dimensions in Inches
Specifications conform to:
ITM Standard

High Speed Steel AMERICAN NATIONAL TAPER PIPE HAND TAPS (GAS) - NGT Ground Threads

ITM Drawing no	Nominal Size	Thread per Inch	Max Thread dia	Thread Length	Overall Length	Shank diameter (h9)	Square Size	
							Size	Length
M-22-531	3/4	14	1.0770	2.1/2	4.1/2	0.750	-	-
M-22-574	3/4	14	1.0770	3.30	5.30	0.750	-	-
M-22-535	3/4	14	1.0750	1.3/8	3.1/4	0.906	0.679	11/16

These Taps are supplied in set of one.

Taps with locking slot having interrupted threads as per ITM Drawing No. M-22-531.

Taps with driving square without interruption as per ITM Drawing No.M-22-574 and M-22-585.

**High Speed Steel
NIB TAPS
METRIC GROUND THREADS
COARSE PITCH**



Nominal Diameter	Pitch	Thread length	Overall Length	Shank diameter (h9)
M3	0.50	15.00	60.00	2.30
M4	0.70	21.00	65.00	3.00
M5	0.80	21.00	70.00	3.80
M6	1.00	30.00	70.00	4.50
M8	1.25	38.00	90.00	6.05
M10	1.50	45.00	95.00	7.80
M12	1.75	53.00	102.00	9.5
M14	2.00	60.00	114.00	11.20
M16	2.00	60.00	127.00	13.10
M18	2.50	75.00	133.00	14.50
M20	2.50	75.00	133.00	16.50
M22	2.50	75.00	146.00	18.50
M24	3.00	90.00	165.00	19.80

These taps are usually supplied in a set of one-piece with thread tolerance 6H



SCREWING TAPS

Dimensions in mm
Specifications conform to:
ITM Standard

Range of Application
For Nut Tapping



SCREWING TAPS



Dimensions are in mm
Specifications conform to:
ITM Standard

High Speed Steel NIB TAPS - BSW GROUND THREADS

Nominal Diameter	Threads Per Inch	Thread length mm	Overall Length mm	Shank diameter mm h9
1/8	40	19.00	60.00	2.20
3/16	24	32.00	75.00	3.00
1/4	20	38.00	85.00	4.50
5/16	18	42.00	90.00	6.00
3/8	16	48.00	95.00	7.30
7/16	14	55.00	102.00	8.60
1/2	12	64.00	110.00	9.50
9/16	12	64.00	114.00	11.40
5/8	11	69.00	127.00	12.70
3/4	10	76.00	133.00	15.50
7/8	9	85.00	146.00	18.50
1	8	95.00	165.00	21.00

These taps are useally supplied in a set of one-piece with thread tolerance Zone 3



TECHNICAL SUPPLY CONDITIONS OF "DAGGER SCREWING TAPS

1. Screwing Taps are normally of the non – serial type taps with straight flutes for RH cutting.
2. Serial Taps, Helical flute taps and special taps are manufactured against specific orders.
3. Intermediate size/ diameter if ordered, shall be supplied with the same dimensions on the next bigger diameter.
4. Other general requirements are maintained according to IS: 6171 – Technical supply conditions for high-speed steel Screweing Taps
5. Hardness:
 Cutting portion: 760 HV to 900 HV
 Driving Square: 320 HV to maximum Hardness equal to cutting Portion (In case of one piece construction)
 320 HV to 450 HV (In case of two piece construction)

5.1 Chamfer dimensions:

No. Of Taps in a set	Type of taps chamfer		Chamfer angle	Length (Approx.)
	Serial	Non - serial		
3 For coarse pitch threads	Rougher Intermediate Finisher	Taper Second Bottoming	5° 10° 20°	8 threads 4 threads *2 to 3 threads
2 (For Fine pitch)	Rougher Finisher	Taper Bottoming	7° 20°	6 threads *2 to 3 threads
1	Nut		2°	20 Threads

*The approximate word indicated in the column heading is not applicable here, as the range has been specified.

5.2 Radial run out when taps are held between centres (T. I. R) (IT Value T.I.R)

Diameter in mm		Radial runout TIR (Micron)		
Above	Up to and including	Taper lead	Thread dia	Shank dia
-	10	30	30	30
10	18	30	30	30
18	30	35	35	40
30	40	40	35	40
40	-	40	40	40

5.3 Taps are usually supplied with a back taper of 1: 1000 maximum and the thread diameters are measured on 2nd or 3rd thread behind the chamfer angle.



TECHNICAL SUPPLY CONDITIONS OF "DAGGER SCREWING TAPS

1. Screwing Taps are normally of the non – serial type taps with straight flutes for RH cutting.
2. Serial Taps, Helical flute taps and special taps are manufactured against specific orders.
3. Intermediate size/ diameter if ordered, shall be supplied with the same dimensions on the next bigger diameter.
4. Other general requirements are maintained according to IS: 6171 – Technical supply conditions for high-speed steel Screweing Taps
5. Hardness:
 Cutting portion: 760 HV to 900 HV
 Driving Square: 320 HV to maximum Hardness equal to cutting Portion (In case of one piece construction)
 320 HV to 450 HV (In case of two piece construction)

5.1 Chamfer dimensions:

No. Of Taps in a set	Type of taps chamfer		Chamfer angle	Length (Approx.)
	Serial	Non - serial		
3 For coarse pitch threads	Rougher Intermediate Finisher	Taper	5°	8 threads 4 threads *2 to 3 threads
		Second	10°	
		Bottoming	20°	
2 (For Fine pitch)	Rougher Finisher	Taper Bottoming	7° 20°	6 threads *2 to 3 threads
1	Nut		2°	20 Threads

*The approximate word indicated in the column heading is not applicable here, as the range has been specified.

5.2 Radial run out when taps are held between centres (T. I. R) (IT Value T.I.R)

Diameter in mm		Radial runout TIR (Micron)		
Above	Up to and including	Taper lead	Thread dia	Shank dia
-	10	30	30	30
10	18	30	30	30
18	30	35	35	40
30	40	40	35	40
40	-	40	40	40

5.3 Taps are usually supplied with a back taper of 1: 1000 maximum and the thread diameters are measured on 2nd or 3rd thread behind the chamfer angle.



5.4 The major diameter and pitch diameter for serial taps are calculated with the following formulas.

Number of taps in a set	Type	Major diameter Min.	Pitch diameter	
			Min	Max
3	Rougher Intermediate Finisher	dB Min - 0.75p dB MIN - 0.35p dB Min	d2BMin - 0.25p d2BMin - 0.08p d2BMin	d2B Max - 0.25p d2B Max - 0.08p d2B Max
2	Rougher Finisher	dB Min - 0.45p dB Min	d2BMin - 0.12 d2BMin	d2B Max - 0.12p d2B Max

Where

- dB Min = minimum major diameter of finisher tap
d2B Min = minimum pitch diameter of finisher tap
d2B Max = maximum pitch diameter of finisher tap
p = pitch of threads

- Serial taps can be supplied in sets or individual pieces as required by the purchaser.
- Taps are normally supplied with tolerance zone 6H. However taps with other tolerance zone are manufactured against specific order.
ISO Metric Taps with thread class 4H are used for tapping internal threads of tolerance zones 4H & 5H recommended for close fit.
Taps with thread tolerance class 6H to be used for tapping internal threads of tolerance zone 4G, 5G & 6H recommended for medium fit.
Taps with threads tolerance class 7H to be used for tapping internal threads of tolerance zones 6G, 7H and 8H - recommended for free fit.
- Tolerance on threaded portion of taps, other than pipe thread taps, are maintained according to IS 6173 Part 1 : 1992

Recommended Rake Angle and Cutting Speed for Taps

Material	Rake Angle	*Cutting Speed m/min
Steel up to 50 Kg/mm ² Tensile Strength	15 - 18	7 - 10
Steel 50-70Kg/mm ² Tensile Strength	12 - 15	5 - 8
Steel 70-90Kg/mm ² Tensile Strength	9 - 12	4 - 6
Steel (Alloy) 90 - 100 Kg/mm ² Tensile Strength	6 - 10	2 - 3
Steel casting up to 70 kg/mm ² Tensile Strength	12 - 15	3 - 5
Malleable cast iron	6 - 10	5 - 8
Cast iron above 200 Be	0 - 3	2 - 3
Cast iron soft	3 - 5	8 - 10
Stainless Steel	10 - 12	3 - 5
brass	0 - 3	8 - 10
Bronze	6 - 12	6 - 8
Copper long chipped	15 - 20	8 - 12
Copper short chipped	6 - 9	8 - 12
Aluminium	20 - 25	10 - 18
Synthetic and plastic material	0 - 3	3 - 5

*The speed mentioned is recommended speed only. Under favourable and near to ideal working condition, this can be further increased.



CUTTING PARAMETERS IN TAPPING & RECOMMENDED CUTTING FLUIDS

The suggested peripheral speed shown in the following table
is only starting points which may be varied considerably to suit service conditions

Work material	Speed 'Vc'		Cutting Fluids
	Metre/min	Ft./min	
ALUMINIUM:	15 - 45	50 - 150	Kerosene & Lard Oil or Kerosene & Light Oil
Aluminium Bronze	6 - 24	20 - 80	Soluble Oil
Bakelite	15 - 30	50 - 100	Dry
Brass	15 - 60	50 - 200	Soluble Oil or Light Base Oil
Cast iron	15 - 30	50 - 100	Dry or Soluble Oil
Copper	9 - 18	30 - 60	Mineral Oil with lard or Light Base Oil
Fibre	24 - 27	80 - 90	Dry
Magnesium	22 - 60	75 - 200	Light Base Oil Diluted with 40% - 50% Kerosene
Malleable iron	10 - 18	35 - 60	Soluble Oil or Sulphur base Oil
Manganese Bronze	9 - 18	30 - 60	Mineral Oil with lard or Light Base Oil
Monel metal	6 - 12	20 - 40	Sulphur base oil
Naval brass	24 - 30	80 - 100	Mineral Oil with lard or Light Base Oil
Phosphor Bronze	9 - 18	30 - 60	Mineral Oil with lard or Light Base Oil
PLASTICS:			
Thermo - plastic	15 - 30	50 - 100	Dry or Air Jet
Thermo - setting	15 - 30	50 - 100	Dry or Air Jet
STEELS:			
Free Machining AISI 1100 Series	18 - 30	60 - 100	Soluble or Sulphur Base oil
Low carbon (up to 0.25%)	12 - 24	60 - 80	Soluble or Sulphur Base oil
Medium Carbon Annealed (0.3 to 0.6%)	9 - 18	30 - 60	Sulphur base oil
Heat treated (0.3 to 0.6% carbon) 224 - 283 brinell	7 - 15	25 - 50	Chlorinated sulphur base oil
Stainless steel	1.5 - 10	5 - 35	Chlorinated sulphur base oil
Titanium alloys	3 - 12	10 - 40	Chlorinated sulphur base oil
Zinc - Die Castings	18 - 45	60 - 150	Kerosene & Lard Oil



TAP DRILL SIZES

Recommendations for drills for use prior to tapping
ISO metric Screw threads
(60° Thread angle)

Nominal diameter mm	Pitch mm	Drill dia mm
1.00	0.25	0.75
1.10	0.25	0.85
1.20	0.25	0.95
1.40	0.30	1.10
1.60	0.35	1.25
1.80	0.35	1.45
2.00	0.40	1.60
2.20	0.45	1.75
2.50	0.35	2.15
2.50	0.45	2.05
3.00	0.35	2.65
3.00	0.50	2.50
3.50	0.35	3.15
3.50	0.60	2.90
4.00	0.50	3.50
4.00	0.70	3.30
4.50	0.50	4.00
4.50	0.75	3.70
5.00	0.50	4.50
5.00	0.80	4.20
5.50	0.50	5.00
6.00	0.75	5.20
6.00	1.00	5.00
7.00	0.75	6.20
7.00	1.00	6.00
8.00	0.75	7.20
8.00	1.00	7.00
8.00	1.25	6.80
9.00	0.75	8.20
9.00	1.00	8.00
9.00	1.25	7.80
10.00	0.75	9.20
10.00	1.00	9.00
10.00	1.25	8.80
10.00	1.50	8.50
11.00	0.75	10.20
11.00	1.00	10.00
11.00	1.50	9.50

Nominal diameter mm	Pitch mm	Drill dia mm
12.00	1.00	11.00
12.00	1.25	10.80
12.00	1.50	10.50
12.00	1.75	10.20
14.00	1.00	13.00
14.00	1.25	12.80
14.00	1.50	12.50
14.00	2.00	12.00
15.00	1.00	14.00
15.00	1.50	13.50
16.00	1.00	15.00
16.00	1.50	14.50
16.00	2.00	14.00
17.00	1.00	16.00
17.00	1.50	15.50
18.00	1.00	17.00
18.00	1.50	16.50
18.00	2.00	16.00
18.00	2.50	15.50
20.00	1.00	19.00
20.00	1.50	18.50
20.00	2.00	18.00
20.00	2.50	17.50
22.00	1.00	21.00
22.00	1.50	20.50
22.00	2.00	20.00
22.00	2.50	19.50
24.00	1.00	23.00
24.00	1.50	22.50
24.00	2.00	22.00
24.00	3.00	21.00
25.00	1.00	24.00
25.00	1.50	23.50
25.00	2.00	23.00
26.00	1.50	24.50
27.00	1.00	26.00
27.00	1.50	25.50
27.00	2.00	25.00



TAP DRILL SIZES

Recommendations for drills for use prior to tapping
ISO metric Screw threads
(60° Thread Angle)

Nominal diameter mm	Pitch mm	Drill dia mm
27.00	3.00	24.00
28.00	1.00	27.00
28.00	1.50	26.50
28.00	2.00	26.00
30.00	1.00	29.00
30.00	1.50	28.50
30.00	2.00	28.00
30.00	3.00	27.00
30.00	3.50	26.50
32.00	1.50	30.50
32.00	2.00	30.00
33.00	1.50	31.50
33.00	2.00	31.00
33.00	3.00	30.00
33.00	3.50	29.50
35.00	1.50	33.50
36.00	1.50	34.50
36.00	2.00	34.00
36.00	3.00	33.00
36.00	4.00	32.00
38.00	1.50	36.50
39.00	1.50	37.50
39.00	2.00	37.00
39.00	3.00	36.00
39.00	4.00	35.00
40.00	1.50	38.50
40.00	2.00	38.00
40.00	3.00	37.00

Nominal diameter mm	Pitch mm	Drill dia mm
42.00	1.50	40.50
42.00	2.00	40.00
42.00	3.00	39.00
42.00	4.00	38.00
42.00	4.50	37.50
45.00	1.50	43.50
45.00	2.00	43.00
45.00	3.00	42.00
45.00	4.00	41.00
45.00	4.50	40.50
48.00	1.50	46.50
48.00	2.00	46.00
48.00	3.00	45.00
48.00	4.00	44.00
48.00	5.00	43.00
50.00	1.50	48.50
50.00	2.00	48.00
50.00	3.00	47.00
52.00	1.50	50.50
52.00	2.00	50.00
52.00	3.00	49.00
52.00	4.00	48.00
52.00	5.00	47.00
56.00	5.50	50.50



Recommendations for Drills
for use prior to tapping Screw threads
BSW and BSF Form
(55° Thread angle)

BSW BRITISH STD. WHITWORTH		
Nominal dia mm	TPI	Drill dia mm
1/8	40	2.55
3/16	24	3.7
1/4	20	5.1
5/16	18	6.5
3/8	16	7.9
7/16	14	9.3
1/2	12	10.5
9/16	12	12.1
5/8	11	13.5
11/16	11	15
3/4	10	16.25
7/8	9	19.25
1	8	22
1 1/8	7	24.75
1 1/4	7	28
1 1/2	6	33.5
1 3/4	5	39
2	4.5	44.5
2.1/4	4	51.0
2.1/2	4	57.0
2.3/4	3.5	62.14
3	3.5	68.30

BSF BRITISH STD. FINE		
Nominal dia mm	TPI	Drill dia mm
3/16	32	4
7/32	28	4.6
1/4	26	5.3
9/32	26	6.1
5/16	22	6.8
3/8	20	8.3
7/16	18	9.7
1/2	16	11.1
9/16	16	12.7
5/8	14	14
11/16	14	15.5
3/4	12	16.75
7/8	11	19.75
1	10	22.75
1 1/8	9	25.5
1 1/4	9	28.5
1 3/8	8	31.5
1 1/2	8	34.5
1.5/8	8	37.90
1.3/4	7	41.00
2	7	47.00
2.1/4	6	53.00
2.1/2	6	58.00
2.3/4	6	63.35
3	5	69.50

BA - British Association (47 1/2° Thread Angle)

Designating no.	Diameter mm	Pitch mm	Nearest Drill Size
0	6.0	1.00	5.10
1	5.3	0.90	4.50
2	4.7	0.81	4.00
3	4.1	0.73	3.40
4	3.6	0.66	3.00
5	3.2	0.59	2.65
6	2.8	0.53	2.30



Recommendations for Drills
for use prior to tapping Screw threads
BSP (Parallel) and BSPT (Taper) Form
(55° Thread angle)

BSP (Parallel)

Nominal diameter Inch	Thread per inch	Nearest drill Size
1/8	28	8.80
1/4	19	11.80
3/8	19	15.25
1/2	14	3/4"
5/8	14	53/64"
3/4	14	24.50
7/8	14	28.25
1	11	30.75
1.1/4	11	39.50
1.1/2	11	1.25/32"
1.3/4	11	51.00
2	11	2.1/4"
2.1/4	11	(63.26)
2.1/2	11	(72.73)
2.3/4	11	(79.08)
3	11	(85.43)
3.1/2	11	(97.88)
4	11	(110.58)

BSPT (Taper)

Nominal diameter Inch	Thread per inch	Nearest drill Size
1/8	28	8.40
1/4	19	11.20
3/8	19	14.75
1/2	14	2.3/32"
3/4	14	15/16"
1	11	30.00
1.1/4	11	38.50
1.1/2	11	44.50
2	11	56.00
2.1/2	11	2.13/16"
3	11	84.35
3.1/2	11	109.42

Sizes given within brackets are hole sizes
Corresponding drill sizes are non - standard



Recommendations for Drills
for use prior to tapping Screw threads
Parallel and Taper Pipe

Pipe Threads - taper 'Rc' series (55° Thread angle)			
Nominal dia (Inch)	TPI	Hole Diameter Cylinder mm	Hole diameter Taper mm (Large Dia)
1/8	28	8.3	8.50
1/4	19	11.00	11.40
3/8	19	14.50	14.90
1/2	14	18.10	18.50
3/4	14	23.50	24.00
1	11	29.60	30.10
1 1/4	11	38.10	38.80
1 1/2	11	44.00	44.70
2	11	55.60	56.50

Pipe Threads - taper 'Rp' series (60° Thread angle)		
Nominal dia (Inch)	TPI	Hole diameter Taper mm
1/8	28	8.60
1/4	19	11.50
3/8	19	15.00
1/2	14	18.50
3/4	14	24.00
1	11	30.25
1 1/4	11	39.00
1 1/2	11	45.00
2	11	56.50
-	-	-

American National Taper Pipe Hand Taps (NPT) (60° Thread angle)			
Nominal dia (Inch)	TPI	Hole Diameter Cylinder mm	Hole diameter Tapered mm Large Dia
1/8	27	8.5	8.70
1/4	18	11.00	11.30
3/8	18	14.40	14.70
1/2	14	17.80	18.20
3/4	14	23.10	23.60
1	11 1/2	29.10	29.60
1 1/4	11 1/2	37.80	38.50
1 1/2	11 1/2	43.90	44.40
2	11 1/2	55.90	56.40

Pipe Threads - parallel 'G' series (55° Thread angle)		
Nominal dia (Inch)	TPI	Hole diameter Taper mm
1/8	28	8.80
1/4	19	11.80
3/8	19	15.25
1/2	14	19.00
5/8	14	21.00
3/4	14	24.50
7/8	14	28.25
1	11	30.75
1 1/4	11	39.50
1 1/2	11	45.00
1 3/4	11	51.00
2	11	57.00



Recommendations for Drills
for use prior to tapping Screw thread
UNC and UNF Form
(60° Thread angle)

UNC UNIFIED COARSE			UNF UNIFIED FINE		
Nominal dia (Inch)	TPI	Drill dia mm	Nominal dia (Inch)	TPI	Drill dia mm
No.1	64.00	1.55	No.0	80	1.25
No.2	56.00	1.85	No.1	72	1.55
No.3	48.00	2.10	No.2	64	1.90
No.4	40.00	2.35	No.3	56	2.15
No.5	40.00	2.65	No.4	48	2.40
No.6	32.00	2.85	No.5	44	2.70
No.8	32.00	3.50	No.6	40	2.95
No.10	24.00	3.90	No.8	36	3.50
No.12	24.00	4.50	No.10	32	4.10
1/4	20.00	5.10	No.12	28	4.70
5/16	18.00	6.60	1/4	28	5.50
3/8	16.00	8.00	5/16	24	6.90
7/16	14.00	9.40	3/8	24	8.50
1/2	13.00	10.80	7/16	20	9.90
9/16	12.00	12.20	1/2	20	11.50
5/8	11.00	13.50	9/16	18	12.90
3/4	10.00	16.50	5/8	18	14.50
7/8	9.00	19.50	3/4	16	17.50
1	8.00	22.25	7/8	14	20.40
1 1/8	7.00	25.00	1	12	23.25
1 1/8	7.00	28.00	1 1/8	12	26.50
1.3/8	6.00	30.75	1 1/4	12	29.50
1 1/2	6.00	34.00	1 3/8	12	32.75
1 3/4	5.00	39.50	1 1/2	12	36.00
2	4.50	45.00	-	-	-



THREAD IDENTIFICATION SYMBOLS

Symbol used for Metric thread

M ISO Metric Screw thread

Symbols used for British threads

BA British Association Standard thread
BSC British Standard Bicycle thread
BSF British Standard Fine thread
BSP British Standard Pipe thread
BSPT British Standard pipe thread, Tapered
BSW British Standard Whitworth coarse thread

Symbols used American threads

Acme – C Acme threads, centralizing
Acme – G Acme threads, general purpose
Stub Acme Stub Acme thread
AMO American Standard microscope objective thread
N. Butt National Buttress thread
NC* American National coarse thread series
NF* American National fine thread series
NEF* American National extra – fine thread series
8N* American National 8 – thread series
12N* American National 12 - thread series
16N* American National 16 – thread series
NH American National hose coupling and fire hose coupling threads
NGO American National gas outlet thread
NM National Miniature thread series
NS* Special threads of American national form
NC American Standard coarse thread series
NF American Standard fine thread series
NPT American Standard taper pipe thread
NPTF American Standard taper pipe thread (dry seal)
NPTR American Standard taper pipe thread for railing fittings
NPS American Standard straight pipe threads
NPSC American Standard straight pipe thread in couplings
NPSF American Standard internal straight pipe thread (dryseal)
NPSI American Standard intermediate internal straight pipe thread (dryseal)
NPSM American Standard straight pipe thread for mechanical joints
NPSL American Standard straight pipe thread for locknuts and locknut pipe threads
NPSH American Standard straight pipe thread for hose couplings and nipples
ANPT Aeronautical taper pipe thread
RMS American Standard surveying instrument mounting thread
UNC Unified coarse thread series
UNF Unified fine thread series
UNEF Unified selected diameter – pitch combinations of the extra – fine thread series
UN Unified selected diameter – pitch combinations of the 8 – 12, and 16 – thread series
UNS Unified threads of selected special diameters, pitches or lengths of engagement

* Non – preferred thread series





TOOL BITS



Dimensions are in mm / inch
 Specifications conform to
 ITM Std.

High Speed Steel GROUND TOOL BITS

8% and 10% Cobalt (8x & 10x) Squares

INCH SERIES					
Size	Length				
3/16	3	4	6	-	-
1/4	3	4	6	8	-
5/16	3	4	6	8	-
3/8	3	4	6	8	-
1/2	3	4	6	8	10
5/8	-	4	6	8	-
3/4	-	4	6	8	-
1	-	-	6	8	-

METRIC SERIES					
Size	Length				
5	75	100	150	-	-
6	75	100	150	200	-
8	75	100	150	200	-
10	75	100	150	200	-
12	75	100	150	200	250
16	-	100	150	200	-
20	-	100	150	200	-
25	-	-	150	200	-

Range of Application
 for use in general turning operations